

2024  
2025



# MEASURING INSTRUMENTS

CATALOGUE NO. EU261

**BEST  
SELLER**

**INSIZE**

All products in this catalogue are usually stocked and available from INSIZE Europe in Spain (subject to our final confirmation)

# PRODUCT INDEX

## 1 DATA OUTPUT

PAGE 1-3



DATA OUTPUT CABLES

## 2 CALIPERS

PAGE 4-27



CALIPERS

## 3 DEPTH MEASUREMENT

PAGE 27-33

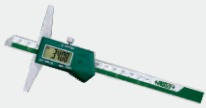

DEPTH GAGES



DEPTH GAGES



DEPTH MICROMETERS

## 5 COMPARISON INSTRUMENTS

PAGE 38-40



CARBON FIBER  
COMPARISON GAGES

## 6 MICROMETERS

PAGE 41-54



HIGH PRECISION DIGITAL  
MICROMETERS/SNAP GAGES



OUTSIDE  
MICROMETERS



3-WIRES



MICROMETER HEADS

## 4 HEIGHT MEASUREMENT

PAGE 33-37



DIGITAL  
HEIGHT GAGES



HEIGHT GAGES

## 7 BORE DIAMETER, CIRCUMFERENCE MEASUREMENT

PAGE 55-64



INSIDE  
MICROMETERS



INSIDE  
MICROMETERS



THREE POINTS  
INTERNAL MICROMETERS



BORE GAGES



TELESCOPING  
GAGE SETS



CIRCUMFERENCE  
METERS

## 8 ARC RADIUS MEASUREMENT

PAGE 64-66



DIGITAL  
RADIUS GAGES



DIGITAL ARC RADIUS  
CALIPERS



DIGITAL RADIUS  
CALIPERS

## 10 INDICATORS, LINEAR GAGES, DIAL INDICATOR STANDS

PAGE 67-88



DIAL TEST  
INDICATORS



INDICATORS



LINEAR GAGES AND  
DISPLAY UNITS

## 9 CHAMFER MEASUREMENT

PAGE 66-67



DIGITAL CHAMFER  
GAGES



DIGITAL CHAMFER  
GAGES



MAGNETIC STANDS



DIAL INDICATOR STANDS  
(NON-MAGNETIC)

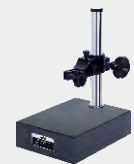

DIAL INDICATOR  
STANDS

# PRODUCT INDEX

## 11 INDICATING MEASURING INSTRUMENTS PAGE 88-95



INTERNAL CALIPER GAGES



EXTERNAL CALIPER GAGES



THICKNESS GAGES



TUBE THICKNESS GAGES



RUBBER THICKNESS GAGES



SNAP GAGES



STEP AND GAP GAGES



MINI DIGITAL HEIGHT GAGES



HEIGHT GAGES



CRANKSHAFT TESTERS



KEYWAY DEPTH GAGES

## 13 ANGLE, STRAIGHTNESS, FLATNESS MEASUREMENT PAGE 110-117

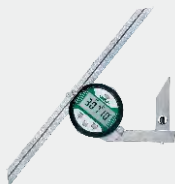

PROTRACTORS



GRANITE SQUARES



PERPENDICULARITY TESTERS



SQUARES



STRAIGHT EDGES



STRAIGHT EDGES

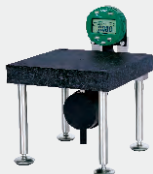

FLATNESS MEASUREMENT STANDS

## 12 STANDARDS AND GAGE BLOCKS PAGE 95-110



GAGE BLOCKS



PIN GAGES



ADJUSTABLE SNAP GAGES



SETTING RINGS



MEASURING BALLS

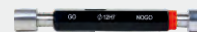

PLAIN PLUG GAGES



THREAD DEPTH GAGES



THREAD PLUG GAGES



THREAD RING GAGES

## 15 SIMPLE MEASURING TOOLS PAGE 122-139



FEELER GAGES



PITCH GAGES



RADIUS GAGES



TAPER SLOT GAGES

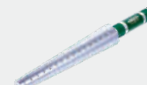

TAPER BORE GAGES



WELDING GAGES



INSIDE/OUTSIDE CALIPERS



MEASURING TAPES



MEASURING TAPES



MEASURING WHEELS



STEEL RULES



COMBINATION SQUARES



T-BEVELS



SCRIBING CALIPERS



PRECISION SCREWDRIVER SETS



MEASURING TOOL SETS

# PRODUCT INDEX

## 14 CONCENTRICITY AND RUNOUT TESTERS PAGE 117-121



CONCENTRICITY GAGES



BENCH CENTERS



SHANK RUNOUT TESTERS

## 17 ON-MACHINE MEASUREMENT PAGE 148-153



CENTERING INDICATORS



EDGE FINDERS



TRIGGER-TYPE 3D PROBES



INFRARED TRANSMISSION PROBES FOR CNC MACHINE TOOLS



ZERO SETTERS WITH CABLE



ZERO SETTERS



ZERO SETTERS

## 18 LEVELS PAGE 154-159



LEVELS



CROSS-LINE LASER LEVELS



SELF-LEVELING ROTARY LASERS

## 19 PAGE 159-162

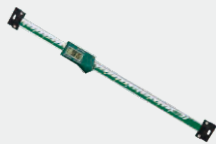

SCALES

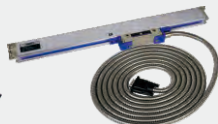

LINEAR SCALES



LASER SCAN MICROMETERS



TOOL PRESETTERS

## 16 SET-UP TOOLS PAGE 140-148



GRANITE SURFACE PLATES



V-BLOCKS

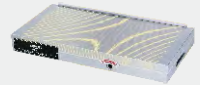

PERMANENT MAGNETIC CHUCKS

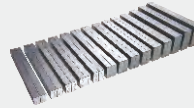

PARALLEL SETS



PARALLEL/SQUARE SETS



ANGLE PLATE SETS



ADJUSTABLE ANGLE BLOCKS



RIGHT ANGLE PLATES



SINE BARS

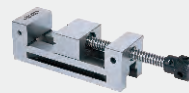

PRECISION VISES

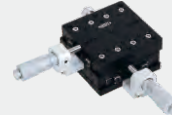

STAGES

## 20 FLAW DETECTORS PAGE 163



DIGITAL ULTRASONIC FLAW DETECTORS

## 21 CMM PAGE 164-166



JIG SETS FOR CMM

## 22 QUICK MEASUREMENT SYSTEMS, VISION MEASURING SYSTEMS PAGE 167-172

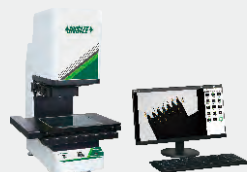

QUICK MEASUREMENT SYSTEMS

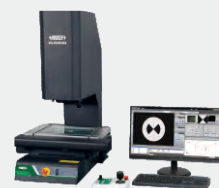

VISION MEASURING SYSTEMS

# PRODUCT INDEX

## 23 MICROSCOPES, MAGNIFIERS PAGE 173-198



TOOLMAKER MICROSCOPES

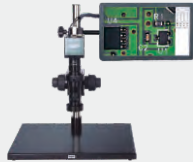

DIGITAL MICROSCOPES



MICROSCOPES



MAGNIFIERS



TELESCOPING INSPECTION MIRRORS

## 24 VIDEOSCOPIES PAGE 199-201



VIDEOSCOPIES

## 25 COATING INSPECTION PAGE 202-209



COATING THICKNESS GAGES



SURFACE PROFILE GAGES



WET FILM GAGES



HOLIDAY DETECTORS



GLOSS METERS



COLORIMETERS

## 27 ELECTRONIC TESTING PAGE 224-229



DC RESISTANCE TESTERS



DC POWER SUPPLIES



DIGITAL MULTIMETERS



DIGITAL AC/DC CLAMP METERS



VOLTAGE TESTERS

## 26 PORTABLE INSTRUMENTS PAGE 209-223



ELECTROMAGNETIC ULTRASONIC THICKNESS GAGES



ULTRASONIC THICKNESS GAGES



TACHOMETERS



VIBRATION METERS



LASER DISTANCE METERS



PORTABLE CONDUCTIVITY/TDS METERS



PORTABLE pH METERS



REFRACTOMETERS



DIGITAL STOPWATCHES



STROKE COUNTERS



DIGITAL MOISTURE METERS



DIFFERENTIAL PRESSURE MANOMETERS



ANEMOMETERS



BOURDON TUBE PRESSURE GAGES



SOUND LEVEL METERS



LIGHT METERS



GAS DETECTORS



TESLAMETERS



LASER BELT TENSION METERS



LIGHT TRANSMITTANCE METERS



DIGITAL GLASS THICKNESS METERS

# PRODUCT INDEX

## 28 TEMPERATURE AND HUMIDITY MEASUREMENT PAGE 229-233



INFRARED THERMAL IMAGING CAMERAS



INFRARED THERMOMETERS



THERMOHYGROMETERS

## 29 ROUNDNESS, PROFILE AND ROUGHNESS TESTERS PAGE 234-240



ROUNDNESS MEASURING MACHINES



SURFACE PROFILE MEASURING MACHINES



ROUGHNESS TESTERS



SURFACE ROUGHNESS SPECIMENS

## 32 TORQUE TESTERS TORQUE WRENCHES PAGE 263-267



TORQUE TESTERS



TORQUE SCREWDRIVERS



TORQUE WRENCHES

## 34 SALT SPRAY TESTERS, TEMPERATURE AND HUMIDITY CHAMBERS PAGE 275



SALT SPRAY TESTERS



TEMPERATURE AND HUMIDITY CHAMBERS

## 30 HARDNESS TESTERS PAGE 241-256



HARDNESS TESTERS

## 31 TESTING MACHINES, FORCE GAGES PAGE 257-263



UNIVERSAL TESTING MACHINES

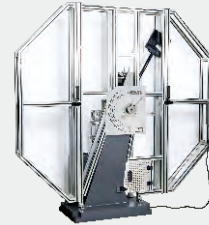

IMPACT TESTING MACHINES



DIGITAL SPRING TESTERS



FORCE GAGES



DIAL TENSION GAGES

## 33 SCALES PAGE 268-274



SCALES



WEIGHTS

## 35 INCH PRODUCTS PAGE 276-277



DIAL CALIPERS



OUTSIDE MICROMETERS



DEPTH MICROMETERS



DIAL INDICATORS



DIAL TEST INDICATORS



FEELER GAGES

## DATA OUTPUT CABLES (KEYBOARD FORMAT)

- Recognized as HID keyboard device by computer, no need to install drivers and softwares
- Data can be transmitted to Excel, Word, txt and other files (press transmit button, which is recognized by the computer as keyboard input data and press enter, such as 12.34 ✓)
- For any softwares which can receive keyboard signal
- Optional accessory: foot switch (code: 7304-2), hub (code: 7324-HUB4, 7324-HUB7), extension cables (code: 7325-ADD5, 7325-ADD10)

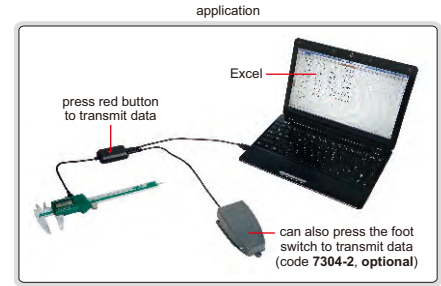
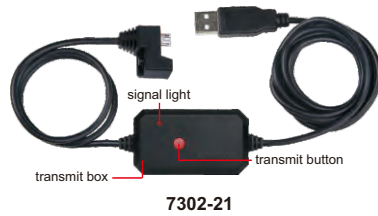

Code	Description	Plug	Connecting with measuring tool	Transmit data
7302-21	cable for digital calipers (length 3m)			<ul style="list-style-type: none"> <li>■ Press the transmit button on the plug of cable, can also press the transmit button of the transmit box, or press the foot switch</li> <li>■ Data is transmitted once, and the signal light of the transmit box flashes once</li> </ul>
7302-22	cable for large digital calipers (length 2.5m)			<ul style="list-style-type: none"> <li>■ Press the transmit button of the transmit box, or press the foot switch</li> <li>■ Data is transmitted once, and the signal light of the transmit box flashes once</li> </ul>
7302-30	cable for digital micrometers (length 2.5m)			<ul style="list-style-type: none"> <li>■ Press the "data" button of digital micrometer, can also press the transmit button of the transmit box, or press the foot switch</li> <li>■ Data is transmitted once, and the signal light of the transmit box flashes once, at the same time, the signal light on the digital micrometer flashes once</li> </ul>
7302-31	cable for digital micrometers (length 2.5m)			<ul style="list-style-type: none"> <li>■ Press the "data" button of digital micrometer, can also press the transmit button of the transmit box, or press the foot switch</li> <li>■ Data is transmitted once, the signal light of the transmit box flashes once, at the same time, the signal light on the digital micrometer flashes once</li> </ul>
7302-40M	cable for digital indicators (length 2.5m)		<p>for 2108, 2138, 2139 series digital indicators</p>	<ul style="list-style-type: none"> <li>■ Press the "DATA" button of digital indicator, can also press the transmit button of the transmit box, or press the foot switch</li> <li>■ Data is transmitted once, and the signal light of the transmit box flashes once, at the same time, the signal light on digital indicator flashes once</li> </ul> <p>Note: long press transmit button to zero the digital indicators</p>
			<p>for other digital indicators</p>	<ul style="list-style-type: none"> <li>■ Press the transmit button of the transmit box, or press the foot switch</li> <li>■ Data is transmitted once, and the signal light of the transmit box flashes once</li> </ul> <p>Note: long press transmit button to zero the digital indicators</p>
7302-50M	cable for digital gages (length 2.5m)			<ul style="list-style-type: none"> <li>■ Press the transmit button of the transmit box, or press the foot switch</li> <li>■ Data is transmitted once, and the signal light of the transmit box flashes once</li> </ul>

**WIRELESS DATA TRANSMISSION SYSTEM**

- Through wireless transmission, the measurement data can be transmitted to computers or mobile phones
- Wireless zigbee protocol, conforming to IEEE802, 2.4GHz band
- Transmission distance is 15 meter (under the condition of no obstruction and no electromagnetic interference)

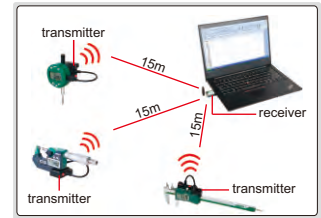

**Transmitter**

- Connecting to digital measuring tools such as calipers, micrometers and indicators
- CR2032 battery

Code	Description	Transmitter	Connecting with measuring tool	Transmit data
7315-21	transmitter for digital calipers			<ul style="list-style-type: none"> <li>Press the transmit button on the plug of cable, can also press the transmit button of the transmitter</li> <li>Data is transmitted once, the signal light of the transmitter flashes once</li> </ul>
7315-22	transmitter for large digital calipers			<ul style="list-style-type: none"> <li>Press the transmit button of the transmitter</li> <li>Data is transmitted once, the signal light of the transmitter flashes once</li> </ul>
7315-31	transmitter for digital micrometers			<ul style="list-style-type: none"> <li>Press the "data" button of digital micrometer</li> <li>Data is transmitted once, the signal light on the digital micrometer flashes once</li> </ul>
7315-50M	transmitter for digital indicators		<p>for 2108, 2138, 2139 series digital indicators</p>	<ul style="list-style-type: none"> <li>Press the "DATA" button of digital indicator, can also press the transmit button of the transmitter</li> <li>Data is transmitted once, the signal light of the transmitter flashes once, at the same time, the signal light on digital indicator flashes once</li> </ul>
			<p>for other digital indicators</p>	<ul style="list-style-type: none"> <li>Press the transmit button of the transmitter</li> <li>Data is transmitted once, the signal light of the transmitter flashes once</li> </ul>
7315-51	transmitter for digital indicators		<p>for 2108, 2138, 2139 series digital indicators</p> <p>foot switch (code 7304-7, optional) back</p>	<ul style="list-style-type: none"> <li>Press the "DATA" button of digital indicator, can also press the foot switch (code 7304-7, optional)</li> <li>Data is transmitted once, the signal light on digital indicator flashes once</li> </ul>

To be continued



Continued from previous page

### Receiver (keyboard signal)

- For computers and mobile phones
- Recognized as HID keyboard device, the transmitted data is recognized by computers or mobile phones as keyboard input data and press enter, such as 12.34 ✓.
- No need to install drivers and softwares
- Data can be transmitted to excel, word, txt etc.
- For any softwares which can receive keyboard signal

Code	Product	Description	Remark
7315-3	USB port	single channel receiver	connected with 1 transmitter only
7315-6	USB port	multichannel receiver	connected with 6 transmitter, each channel has status indicator
7315-7	type-C port		
7315-8	micro USB port		
7315-9	lightning port		

### Receiver (text format, virtual com port)

- For computers with windows system
- Text format virtual com port, converted to keyboard format with supplied software
- Supplied with EXCEL directional input software
- Measurement data can be transmitted to excel, word, txt etc. and any software which receives keyboard signal

Code	Product	Description	Remark
7315-2	antenna  USB port	multichannel receiver	connected with maximum 16 transmitters, each of them has unique identification code

### EXCEL directional input software

- Supplied with 7315-2 receiver
- The measurement data of multiple measuring tools can be transmitted to the designated area of excel, which facilitates data management and improves efficiency

Excel directional input software (included in 7315-2), application example 1

Set the display area of caliper at B4-B9, the readings of caliper are displayed at B4, B5...B9.  
Set the display area of micrometer at C4-C9, the readings of micrometer are displayed at C4, C5... C9.  
Set the display area of height gage at D4-D9, the readings of height gage are displayed at D4, D5... D9.

Project	Length	Width	Height
Dimension and Tolerance	50±0.05	24±0.01	10±0.05±0.06
Measuring tool	Caliper	Micrometer	Height gage
1	50.02	24.004	9.98
2	50.01	24.010	10.01
3	49.99	23.999	10.02
4	50.00	23.996	9.99
5	50.04	24.000	10.01
6	50.03	24.000	10.01

serial of workpieces      the next data display area is indicated in green

Excel directional input software (included in 7315-2), application example 2

Set the display area of micrometer at B4-C9, data input is from the left to the right, the readings of micrometer are displayed at B4, C4, B5, C5... B9, C9.  
Set the display area of caliper at D4-D9, the readings of caliper are displayed at D4, D5... D9.  
Set the display area of depth gage at E4-E9, the readings of depth gage are displayed at E4, E5... E9.

Project	External diameter1	External diameter2	Length	Depth
Dimension and Tolerance	Φ21±0.01±0.02	Φ21±0.01±0.02	50±0.04	28±0.05
Measuring tool	Micrometer	Micrometer	Caliper	Depth gage
1	21.010	21.008	49.98	28.01
2	21.010	21.000	49.98	27.98
3	22.999	21.000		
4	23.987	20.998	50.01	28.01
5	23.800	20.985	50.01	28.01
6	21.005	21.000	49.98	28.01

serial of workpieces      the next data display area is indicated in green

### FOOT SWITCH

- For data transmission



7304-2

Code	Description	Applicable products
7304-2	data transmission foot switch with cable (length 2m)	7302 series data cables 7305 series data cables

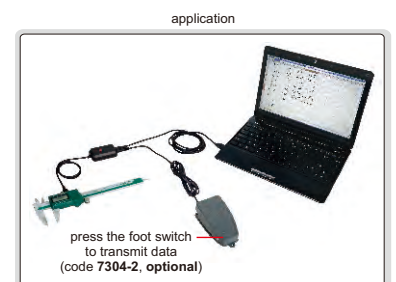

## IP67 WATERPROOF DIGITAL CALIPERS



ATTENTION: IT IS NECESSARY TO SET ZERO AFTER POWER ON EACH TIME

ATTENTION: NO DATA OUTPUT

**IP67**  
WATERPROOF

- Accuracy:  $\pm 0.03\text{mm}$
- IP67 dust/waterproof
- Resolution: 0.01mm/0.0005"
- Button function: zero, on/off, mm/inch, ABS/REL, hold
- Battery CR2032, meet DIN862
- Made of stainless steel



1118-150B

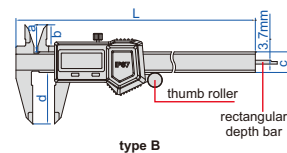

type B

(mm)

Code	Range	Thumb roller	Type	L	a	b	c	d
1118-150B*	0-150mm/0-6"	with	B	236	21	16	16	40
1118-200B*	0-200mm/0-8"	with	B	286	24	19	16	50
1118-300B*	0-300mm/0-12"	with	B	400	25	20.5	16	60
1118-150BW*	0-150mm/0-6"	without	B	236	21	16	16	40
1118-200BW*	0-200mm/0-8"	without	B	286	24	19	16	50
1118-300BW*	0-300mm/0-12"	without	B	400	25	20.5	16	60
1118-150R*	0-150mm/0-6"	with	R	236	21	16	16	40



1118-150R

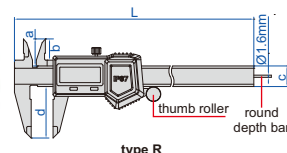

type R

\*Supplied with manufacturer inspection certificate

## IP67 WATERPROOF DIGITAL CALIPERS



ATTENTION: NO DATA OUTPUT

**IP67**  
WATERPROOF

- IP67 dust/waterproof
- Resolution: 0.01mm/0.0005"
- Button function: zero, on/off, mm/inch
- Battery CR2032
- Automatic power off
- Meet DIN862
- Made of stainless steel



1115-150

Code	Range	Accuracy	L	a	b	c	d
1115-150*	0-150mm/0-6"	$\pm 0.03\text{mm}$	235mm	20mm	15mm	16mm	40mm
1115-200*	0-200mm/0-8"	$\pm 0.03\text{mm}$	287mm	24mm	19mm	16mm	50mm
1115-300*	0-300mm/0-12"	$\pm 0.03\text{mm}$	388mm	26mm	21mm	16mm	60mm

\*Supplied with manufacturer inspection certificate

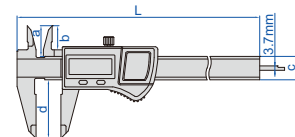

## WIRELESS DIGITAL CALIPERS



ATTENTION: THE WORKING LIFE OF A BATTERY IS ABOUT 3-5 MONTHS



- Non waterproof
- Built-in wireless data transmission module, Zigbee signal
- Transmission distance is 10 meter (under the condition of no obstruction and no electromagnetic interference)
- Accuracy:  $\pm 0.03\text{mm}$
- Resolution: 0.01mm/0.0005"
- Buttons: on/off, zero, mm/inch, data transmission
- Automatic power off, move the digital unit to turn on power
- Battery CR2032
- Made of stainless steel
- Optional accessory: receiver (code 7315-2/3/6/7/8/9)

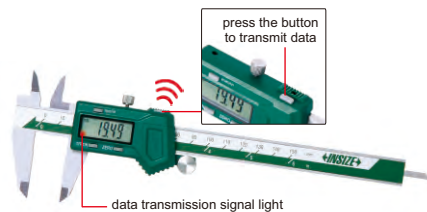

1113-150

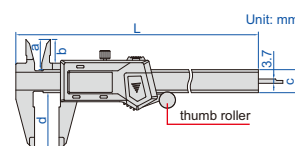

(mm)

Code	Range	Thumb roller	L	a	b	c	d
1113-150*	0-150mm/0-6"	with	236	21	16	16	40
1113-200*	0-200mm/0-8"	with	286	24	19	16	50
1113-300*	0-300mm/0-12"	with	400	25	20.5	16	60
1113-150W*	0-150mm/0-6"	without	236	21	16	16	40
1113-200W*	0-200mm/0-8"	without	286	24	19	16	50
1113-300W*	0-300mm/0-12"	without	400	25	20.5	16	60

\*Supplied with manufacturer inspection certificate

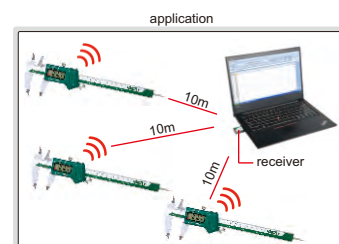
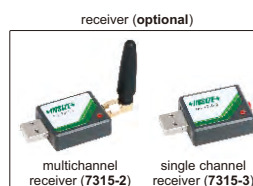

## DIGITAL CALIPERS (FRACTION READING)

- Non waterproof
- Resolution: 1/128", 0.01mm, 0.0005"
- Buttons: unit (inch fraction/mm/inch), on/off, zero
- Automatic power off, move the digital unit to turn on power
- Battery CR2032
- Data output (for mm and inch)
- Meet DIN862
- Made of stainless steel
- Optional accessory: data output cable (code **7315-21** need receiver, **7302-21**)



1102-150

INSPECTION CERTIFICATE

DATA OUTPUT

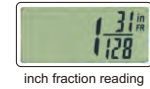

inch fraction reading



mm reading



inch reading

(mm)							
Code	Range	Accuracy	Thumb roller	L	a	b	d
1102-150*	0-150mm/0-6"	±0.02mm	with	236	21	16	40
1102-200*	0-200mm/0-8"	±0.03mm	with	286	24	19	50
1102-300*	0-300mm/0-12"	±0.03mm	with	400	25	20.5	60
1102-150W*	0-150mm/0-6"	±0.02mm	without	236	21	16	40
1102-200W*	0-200mm/0-8"	±0.03mm	without	286	24	19	50
1102-300W*	0-300mm/0-12"	±0.03mm	without	400	25	20.5	60

\*Supplied with manufacturer inspection certificate

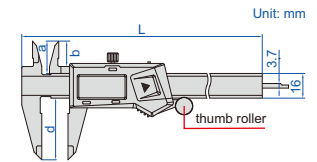

## DIGITAL CALIPERS (ABSOLUTE SYSTEM)

- Non waterproof
- Accuracy: ±0.03mm
- Absolute system, low power consumption, long battery life
- Resolution: 0.01mm/0.0005"
- Buttons: on/off, mm/inch, ORIGIN, ZERO/ABS
- Automatic power off, move the digital unit to turn on power
- Battery CR2032, data output
- Meet DIN862
- Made of stainless steel
- Optional accessory: wireless transmitter, code **7315-22** need receiver, data output cable (keyboard format), code **7302-22**



1103-150

INSPECTION CERTIFICATE

DATA OUTPUT

(mm)							
Code	Range	Thumb roller	L	a	b	d	
1103-150*	0-150mm/0-6"	with	236	21	16.5	40	
1103-200*	0-200mm/0-8"	with	286	24	19.5	50	
1103-300*	0-300mm/0-12"	with	400	26	21.5	60	
1103-150W*	0-150mm/0-6"	without	236	21	16.5	40	
1103-200W*	0-200mm/0-8"	without	286	24	19.5	50	
1103-300W*	0-300mm/0-12"	without	400	26	21.5	60	

\*Supplied with manufacturer inspection certificate

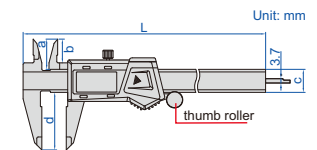

## DIGITAL CALIPERS

- Non waterproof
- Zinc alloy housing for digital unit
- Resolution: 0.01mm/0.0005"
- Buttons: zero, on/off, mm/inch
- Automatic power off, move the digital unit to turn on power
- Battery CR2032, meet DIN862
- Made of stainless steel



1114-150A

INSPECTION CERTIFICATE

ATTENTION: NO DATA OUTPUT

Code	Range	Accuracy	Thumb roller	L	a	b	c	d
1114-150A*	0-150mm/0-6"	±0.03mm	with	236mm	21mm	16mm	16mm	40mm
1114-200A*	0-200mm/0-8"	±0.03mm	with	286mm	24mm	19mm	16mm	50mm
1114-300A*	0-300mm/0-12"	±0.03mm	with	400mm	25mm	20.5mm	17mm	60mm
1114-150AW*	0-150mm/0-6"	±0.03mm	without	236mm	21mm	16mm	16mm	40mm
1114-200AW*	0-200mm/0-8"	±0.03mm	without	286mm	24mm	19mm	16mm	50mm
1114-300AW*	0-300mm/0-12"	±0.03mm	without	400mm	25mm	20.5mm	17mm	60mm

\*Supplied with manufacturer inspection certificate

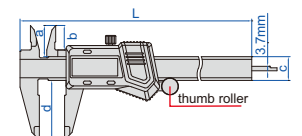

## DIGITAL CALIPERS (STANDARD TYPE)

- Non waterproof
- Resolution: 0.01mm/0.0005"
- Buttons: on/off, zero, mm/inch
- Automatic power off, move the digital unit to turn on power
- Battery CR2032
- Data output, meet DIN862
- Made of stainless steel
- Optional accessory: data output cable (code 7315-21 need receiver, 7302-21)



1108-150

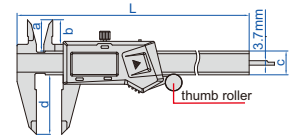

Code	Range	Accuracy	Thumb roller	L	a	b	c	d
1108-150*	0-150mm/0-6"	±0.02mm	with	236mm	21mm	16mm	16mm	40mm
1108-200*	0-200mm/0-8"	±0.03mm	with	286mm	24mm	19mm	16mm	50mm
1108-300*	0-300mm/0-12"	±0.03mm	with	400mm	25mm	20.5mm	16mm	60mm
1108-150W*	0-150mm/0-6"	±0.02mm	without	236mm	21mm	16mm	16mm	40mm
1108-200W*	0-200mm/0-8"	±0.03mm	without	286mm	24mm	19mm	16mm	50mm
1108-300W*	0-300mm/0-12"	±0.03mm	without	400mm	25mm	20.5mm	16mm	60mm

\*Supplied with manufacturer inspection certificate

## HEAVY DUTY 300mm DIGITAL CALIPERS



1196-300

- Non waterproof
- Resolution: 0.01mm/0.0005"
- Buttons: on/off, zero, mm/inch
- Automatic power off, move the digital unit to turn on power
- Battery CR2032
- Data output
- Meet DIN862
- Made of stainless steel
- Optional accessory: data output cable (code 7315-22 need receiver, 7302-22)

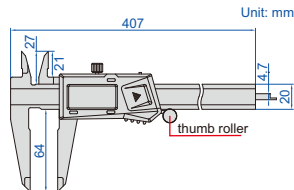

Code	Range	Accuracy	Thumb roller
1196-300*	0-300mm/0-12"	±0.03mm	with
1196-300W*	0-300mm/0-12"	±0.03mm	without

\*Supplied with manufacturer inspection certificate

## DIGITAL CALIPERS WITH ROUND DEPTH BAR



1119-150



- Non waterproof
- Resolution: 0.01mm/0.0005"
- Buttons: on/off, zero, mm/inch
- Automatic power off, move the digital unit to turn on power
- Battery CR2032
- Data output
- Meet DIN862
- Made of stainless steel
- Optional accessory: data output cable (code 7315-21 need receiver, 7302-21)

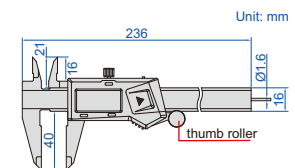

Code	Range	Accuracy	Thumb roller
1119-150*	0-150mm/0-6"	±0.03mm	with
1119-150W*	0-150mm/0-6"	±0.03mm	without

\*Supplied with manufacturer inspection certificate

## METRIC DIGITAL CALIPERS



1109-150

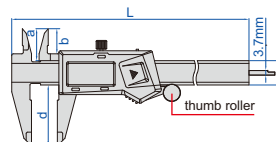

- Non waterproof
- Resolution: 0.01mm
- Buttons: on/off, zero, hold
- Automatic power off, move the digital unit to turn on power
- Battery CR2032
- Data output, meet DIN862
- Made of stainless steel
- Optional accessory: data output cable (code 7315-21 need receiver, 7302-21)

Code	Range	Accuracy	Thumb roller	L	a	b	c	d
1109-150*	0-150mm	±0.03mm	with	236	21	16	16	40
1109-200*	0-200mm	±0.03mm	with	286	24	19	16	50
1109-300*	0-300mm	±0.03mm	with	400	25	20.5	16	60
1109-150W*	0-150mm	±0.03mm	without	236	21	16	16	40
1109-200W*	0-200mm	±0.03mm	without	286	24	19	16	50
1109-300W*	0-300mm	±0.03mm	without	400	25	20.5	16	60

\*Supplied with manufacturer inspection certificate

## LEFT HAND DIGITAL CALIPERS

INSPECTION  
CERTIFICATE

DATA  
OUTPUT

- Non waterproof
- Designed for left handed users
- Resolution: 0.01mm/0.0005"
- Buttons: on/off, zero, mm/inch
- Automatic power off, move the digital unit to turn on power
- Battery CR2032, data output
- Meet DIN862
- Made of stainless steel
- Optional accessory: data output cable (code 7315-22 need receiver, 7302-22)



1130-150

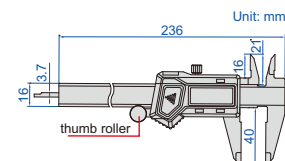

Code	Range	Accuracy	Thumb roller
1130-150*	0-150mm/0-6"	±0.03mm	with
1130-150W*	0-150mm/0-6"	±0.03mm	without

\*Supplied with manufacturer inspection certificate

## DIGITAL CALIPERS WITH CERAMIC TIPPED JAWS

INSPECTION  
CERTIFICATE

DATA  
OUTPUT

- Non waterproof
- Ceramic tipped jaws for outside measurement, extremely wear-resistant, non-magnetic and non electric conductive
- Resolution: 0.01mm/0.0005"
- Buttons: on/off, zero, mm/inch
- Automatic power off, move the digital unit to turn on power
- Battery CR2032, data output
- Made of stainless steel
- Meet DIN862
- Optional accessory: data output cable (code 7315-21 need receiver, 7302-21)



1193-150

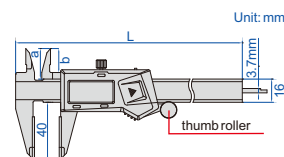

ceramic  
tipped jaws



Code	Range	Accuracy	Thumb roller	L	a	b
1193-150*	0-150mm/0-6"	±0.03mm	with	235	21	16.5
1193-150W*	0-150mm/0-6"	±0.03mm	without	235	21	16.5

(mm)

\*Supplied with manufacturer inspection certificate

## DIGITAL CALIPERS WITH CARBIDE TIPPED JAWS

INSPECTION  
CERTIFICATE

DATA  
OUTPUT

- Non waterproof
- Accuracy: ±0.03mm
- Resolution: 0.01mm/0.0005"
- Buttons: on/off, zero, mm/inch
- Automatic power off, move the digital unit to turn on power
- Battery CR2032, data output
- Meet DIN862
- Made of stainless steel
- Optional accessory: data output cable (code 7315-21 need receiver, 7302-21)

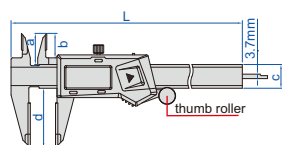

1110-150A



1110-150B

### Carbide tipped upper and lower jaws (mm)

Code	Range	Thumb roller	L	a	b	c	d
1110-150A*	0-150mm/0-6"	with	236	21	16	16	40
1110-200A*	0-200mm/0-8"	with	286	24	19	16	50
1110-300A*	0-300mm/0-12"	with	400	25	20.5	16	60
1110-150AW*	0-150mm/0-6"	without	236	21	16	16	40
1110-200AW*	0-200mm/0-8"	without	286	24	19	16	50
1110-300AW*	0-300mm/0-12"	without	400	25	20.5	16	60

### Carbide tipped lower jaws (mm)

Code	Range	Thumb roller	L	a	b	c	d
1110-150B*	0-150mm/0-6"	with	236	21	16	16	40
1110-200B*	0-200mm/0-8"	with	286	24	19	16	50
1110-300B*	0-300mm/0-12"	with	400	25	20.5	16	60
1110-150BW*	0-150mm/0-6"	without	236	21	16	16	40
1110-200BW*	0-200mm/0-8"	without	286	24	19	16	50
1110-300BW*	0-300mm/0-12"	without	400	25	20.5	16	60

\*Supplied with manufacturer inspection certificate

**DIGITAL CALIPERS**

**DATA OUTPUT**



1170-300

- Non waterproof
- Resolution: 0.01mm/0.0005"
- Buttons: on/off, zero, mm/inch
- Automatic power off, move the digital unit to turn on power
- Battery CR2032
- Data output
- Made of stainless steel
- Optional accessory: data output cable (code 7315-21 need receiver, 7302-21)

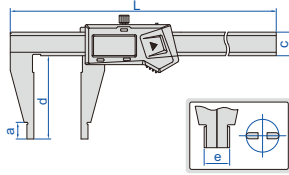

(mm)

Code	Range	Accuracy	L	a	c	d	e
1170-200	0-200mm/0-8"	±0.03mm	314	12	17	60	10
1170-306	0-300mm/0-12"	±0.04mm	420	12	17	60	10
1170-300	0-300mm/0-12"	±0.06mm	420	12	17	90	10

**DIGITAL CALIPERS**

**DATA OUTPUT**



1171-300

- Non waterproof
- Resolution: 0.01mm/0.0005"
- Buttons: on/off, zero, mm/inch
- Automatic power off, move the digital unit to turn on power
- Battery CR2032
- Data output
- Made of stainless steel
- Optional accessory: data output cable (code 7315-21 need receiver, 7302-21)

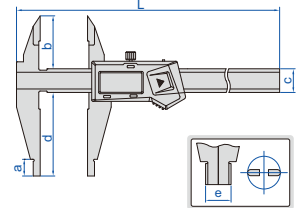

(mm)

Code	Range	Accuracy	L	a	b	c	d	e
1171-200	0-200mm/0-8"	±0.03mm	320	12	38	17	60	10
1171-306	0-300mm/0-12"	±0.04mm	420	12	38	17	60	10
1171-300	0-300mm/0-12"	±0.06mm	420	12	38	17	90	10

**MINI DIGITAL CALIPERS**

**ATTENTION: NO DATA OUTPUT**



1111-100A

- Non waterproof
- Resolution: 0.01mm/0.0005"
- Buttons: zero, mm/inch, on/off
- Automatic power off, move the digital unit to turn on power
- Battery LR44
- Meet DIN862
- Made of stainless steel

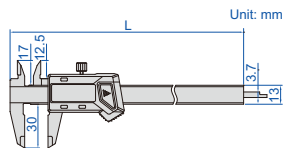

Unit: mm

Code	Range	Accuracy	L
1111-75A	0-75mm/0-3"	±0.02mm	144mm
1111-100A	0-100mm/0-4"	±0.02mm	170mm

**PLASTIC DIGITAL CALIPER**

**ATTENTION: NO DATA OUTPUT**



1139-150

- Non waterproof
- Made of hard plastic, non-magnetic and non electric conductive
- Prevent workpieces from scratching by calipers
- Resolution: 0.01mm/0.0005"
- Buttons: on/off, zero, mm/inch
- Battery CR2032, automatic power off

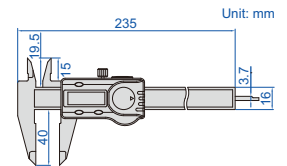

Unit: mm

Code	Range	Accuracy
1139-150	0-150mm/0-6"	±0.1mm

**MINI VERNIER CALIPERS**

- Meet DIN862
- Made of stainless steel
- Satin chrome plated reading surface

Code	Range	Graduation	Accuracy
1204-70	0-70mm	0.05mm	±0.05mm



1204-70

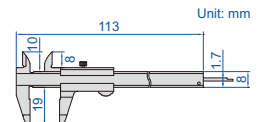

Unit: mm

Code	Range	Graduation	Accuracy
1203-1003	0-100mm	0.05mm	±0.05mm



1203-1003

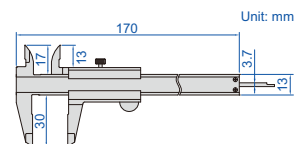

Unit: mm

Code	Range	Graduation	Accuracy
1201-1003	0-100mm	0.05mm	±0.05mm



1201-1003

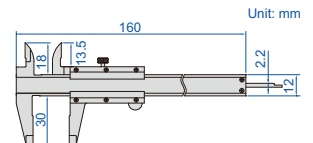

Unit: mm

## VERNIER CALIPERS

- Meet DIN862
- Made of stainless steel
- Satin chrome plated reading surface



POPULAR MODEL

1205-150S

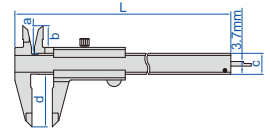

Graduation 0.05mm/1/128" (mm)

Code	Range	Accuracy	L	a	b	c	d
1205-150S	0-150mm/0-6"	±0.05mm	235	20.5	15.5	16	40
1205-200S	0-200mm/0-8"	±0.05mm	290	23.5	19	17	50
1205-300S	0-300mm/0-12"	±0.05mm	414	27.5	22	20	64

Graduation 0.02mm/0.001" (mm)

Code	Range	Accuracy	L	a	b	c	d
1205-1502S	0-150mm/0-6"	±0.03mm	235	20.5	15.5	16	40
1205-2002S	0-200mm/0-8"	±0.03mm	290	23.5	19	17	50
1205-3002S	0-300mm/0-12"	±0.03mm	414	27.5	22	20	64

Graduation 0.05mm (mm)

Code	Range	Accuracy	L	a	b	c	d
1205-1503S	0-150mm	±0.05mm	235	20.5	15.5	16	40
1205-2003S	0-200mm	±0.05mm	290	23.5	19	17	50
1205-3003S	0-300mm	±0.05mm	414	27.5	22	20	64

Graduation 0.02mm (mm)

Code	Range	Accuracy	L	a	b	c	d
1205-1501S	0-150mm	±0.03mm	235	20.5	15.5	16	40
1205-2001S	0-200mm	±0.03mm	290	23.5	19	17	50
1205-3001S	0-300mm	±0.03mm	414	27.5	22	20	64

## VERNIER CALIPER WITH ROUND DEPTH BAR

- Graduation: 0.05mm/1/128"
- Round depth bar
- Meet DIN862
- Made of stainless steel
- Satin chrome plated reading surface



1202-150

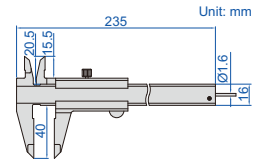

Code	Range	Accuracy
1202-150	0-150mm/0-6"	±0.05mm

## VERNIER CALIPERS WITH THUMB CLAMP



1223-150

- Meet DIN862
- With thumb clamp
- Made of stainless steel
- Satin chrome plated reading surface

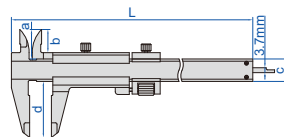

Graduation 0.05mm/1/128" (mm)

Code	Range	Accuracy	L	a	b	c	d
1223-150	0-150mm/0-6"	±0.05mm	230	20.5	16.5	16	40
1223-200	0-200mm/0-8"	±0.05mm	295	23.5	19	16	50

Graduation 0.02mm/0.001" (mm)

Code	Range	Accuracy	L	a	b	c	d
1223-1502	0-150mm/0-6"	±0.03mm	230	20.5	16.5	16	40
1223-2002	0-200mm/0-8"	±0.03mm	295	23.5	19	16	50

## VERNIER CALIPERS



1217-3001

- With fine adjustment
- Made of stainless steel
- Satin chrome plated reading surface

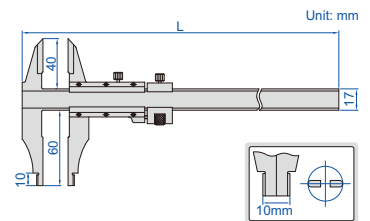

Code	Range	Graduation	Accuracy	L
1217-2503	0-250mm	0.05mm	±0.05mm	360mm
1217-3001	0-300mm	0.02mm	±0.03mm	410mm

## VERNIER CALIPERS (ANTI MAGNETIC)

- Suitable for magnetic parts
- Made of pure copper

ATTENTION:  
NOT HARDENED

PURE COPPER



1224-150A

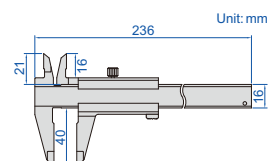

Code	Range	Graduation	Accuracy
1224-150A	0-150mm	0.02mm	±0.05mm
1224-1501A	0-150mm	0.05mm	±0.05mm

## LEFT HAND VERNIER CALIPERS

- Designed for left handed users
- Made of stainless steel
- Satin chrome plated reading surface

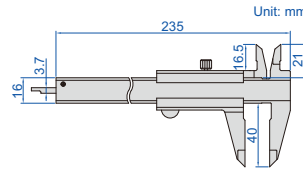

1239-1502

Code	Range	Graduation	Accuracy
1239-150	0-150mm/0-6"	0.05mm/1/128"	±0.05mm
1239-1502	0-150mm/0-6"	0.02mm/0.001"	±0.03mm

## DIAL CALIPERS

- Shockproof dial indicator
- Made of stainless steel

INSPECTION CERTIFICATE

SHOCK PROOF



1312-150A

Dial indicator graduation: 0.02mm (mm)

Code	Range	Accuracy	L	a	b	c	d	D	t
1312-150A*	0-150mm	±0.03mm	235	21	16.5	16	40	∅39	6.5
1312-200A*	0-200mm	±0.03mm	288	24	19	16	48	∅39	6.5
1312-300A*	0-300mm	±0.03mm	410	28	22	20	62	∅44.5	7.5

Dial indicator graduation: 0.01mm (mm)

Code	Range	Accuracy	L	a	b	c	d	D	t
1311-150A*	0-150mm	±0.03mm	235	21	16.5	16	40	∅39	6.5
1311-200A*	0-200mm	±0.03mm	288	24	19	16	48	∅39	6.5
1311-300A*	0-300mm	±0.03mm	410	28	22	20	62	∅44.5	7.5

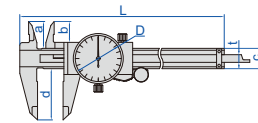

\*Supplied with manufacturer inspection certificate

## DIAL CALIPERS

- Shockproof dial indicator
- Dial indicator graduation: 0.02mm
- Made of stainless steel



1316-500

SHOCK PROOF

Code	Range	Accuracy	a	c	d	e	L
1316-500	0-500mm	±0.05mm	18mm	21mm	90mm	20mm	650mm
1316-600	0-600mm	±0.05mm	18mm	21mm	90mm	20mm	750mm
1316-1000	0-1000mm	±0.07mm	24mm	28mm	150mm	20mm	1190mm
1316-1500	0-1500mm	±0.11mm	24mm	28mm	150mm	20mm	1690mm

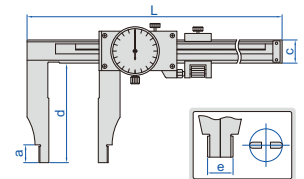

## DIGITAL CALIPERS

- Non waterproof
- Resolution: 0.01mm/0.0005"
- Button function: on/off, zero, mm/inch, ABS, data preset
- Battery CR2032, data output
- Made of stainless steel



1106-501

POPULAR MODEL

DATA OUTPUT

(mm)

Code	Range	Accuracy	a	c	d	e	L	Data output cable (optional)
1106-301	0-300mm/0-12"	±0.05mm	18	24	100	20	420	7315-22 need receiver, 7302-22
1106-302	0-300mm/0-12"	±0.05mm	18	24	150	20	420	7315-22 need receiver, 7302-22
1106-451	0-450mm/0-18"	±0.05mm	18	24	100	20	625	7315-22 need receiver, 7302-22
1106-501	0-500mm/0-20"	±0.05mm	18	24	100	20	675	7315-22 need receiver, 7302-22
1106-502	0-500mm/0-20"	±0.06mm	18	24	150	20	675	7315-22 need receiver, 7302-22
1106-503	0-500mm/0-20"	±0.06mm	24	31	200	20	675	7315-22 need receiver, 7302-22
1106-601	0-600mm/0-24"	±0.05mm	18	24	100	20	770	7315-22 need receiver, 7302-22
1106-802	0-800mm/0-32"	±0.07mm	24	31	150	20	1025	7315-22 need receiver, 7302-22
1106-1002	0-1000mm/0-40"	±0.08mm	24	31	150	20	1220	7315-22 need receiver, 7302-22
1106-1502	0-1500mm/0-60"	±0.11mm	24	42	150	20	1780	7315-20B need receiver, 7302-SPC1A
1106-2002	0-2000mm/0-80"	±0.14mm	24	42	150	20	2290	7315-20B need receiver, 7302-SPC1A

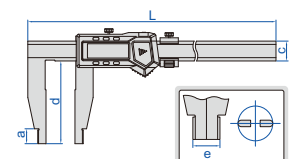



### DIGITAL CALIPERS

DATA OUTPUT



1135-601

- Non waterproof
- Resolution: 0.01mm/0.0005"
- Button function: on/off, zero, mm/inch, ABS, data preset
- Battery CR2032
- Data output
- Made of stainless steel
- Optional accessory: data output cable (code 7315-22 need receiver, 7302-22)

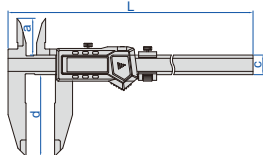

(mm)

Code	Range	Accuracy	a	c	d	e	L
1135-451	0-450mm/0-18"	±0.05mm	45	24	100	625	
1135-601	0-600mm/0-24"	±0.05mm	45	24	100	770	
1135-1002	0-1000mm/0-40"	±0.08mm	60	31	150	1220	

### DIGITAL CALIPERS

DATA OUTPUT



1136-501

- Non waterproof
- Resolution: 0.01mm/0.0005"
- Button function: on/off, zero, mm/inch, ABS, data preset
- Battery CR2032
- Data output
- Made of stainless steel
- Optional accessory: data output cable (code 7315-22 need receiver, 7302-22)

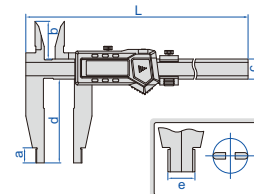

(mm)

Code	Range	Accuracy	a	b	c	d	e	L
1136-301	0-300mm/0-12"	±0.05mm	18	45	24	100	20	420
1136-501	0-500mm/0-20"	±0.05mm	18	45	24	100	20	675
1136-502	0-500mm/0-20"	±0.06mm	18	45	24	150	20	675
1136-601	0-600mm/0-24"	±0.05mm	18	45	24	100	20	770
1136-1002	0-1000mm/0-40"	±0.08mm	24	60	31	150	20	1220

### VERNIER CALIPERS (SEPARATE TYPE)

POPULAR MODEL



1214-500

separate type (with screws)

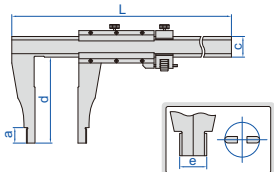

- Graduation 0.02mm/0.001"
- With fine adjustment
- Made of stainless steel
- Satin chrome plated reading surface

(mm)

Code	Range	Accuracy	a	c	d	e	L
1214-300	0-300mm/0-12"	±0.05mm	10	20	75	10	410
1214-450	0-450mm/0-18"	±0.05mm	18	24	100	20	620
1214-500	0-500mm/0-20"	±0.05mm	18	24	100	20	670
1214-600	0-600mm/0-24"	±0.05mm	18	24	100	20	770
1214-1000	0-1000mm/0-40"	±0.08mm	24	32	140	20	1216

### LONG JAW VERNIER CALIPERS (SEPARATE TYPE)



1215-1034

separate type (with screws)

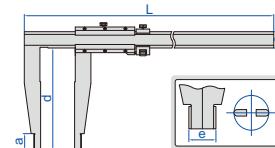

- With fine adjustment
- Made of stainless steel
- Satin chrome plated reading surface

Graduation 0.05mm/1/128"

(mm)

Code	Range	Accuracy	a	c	d	e	L
1215-524	0-500mm/0-20"	±0.08mm	18	24	150	20	670
1215-1034	0-1000mm/0-40"	±0.12mm	24	32	200	20	1330

### VERNIER CALIPERS (SOLID TYPE)

solid type (without screw)



1236-511

- With fine adjustment
- Made of stainless steel
- Satin chrome plated reading surface

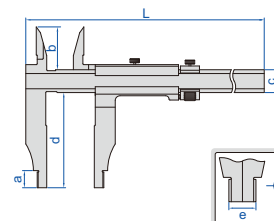

Graduation 0.05mm/1/128"

(mm)

Code	Range	Accuracy	a	b	c	d	e	L
1236-524	0-500mm/0-20"	±0.08mm	18	45	24	150	20	670
1236-614	0-600mm/0-24"	±0.08mm	18	45	24	100	20	770
1236-1024	0-1000mm/0-40"	±0.12mm	24	60	31	150	20	1230

Graduation 0.02mm

(mm)

Code	Range	Accuracy	a	b	c	d	e	L
1236-511	0-500mm	±0.05mm	18	45	24	100	20	670
1236-1021	0-1000mm	±0.08mm	24	60	31	150	20	1230

### VERNIER CALIPER (SOLID TYPE)



1207-394

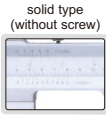

solid type (without screw)

- Graduation 0.05mm/1/128"
- With fine adjustment
- Made of stainless steel
- Satin chrome plated reading surface

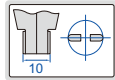
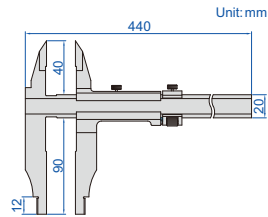

Code	Range	Accuracy
1207-394	0-300mm/0-12"	±0.07mm

### VERNIER CALIPERS (SOLID TYPE)



1208-521

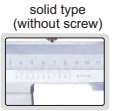

solid type (without screw)

- With fine adjustment
- Made of stainless steel
- Satin chrome plated reading surface

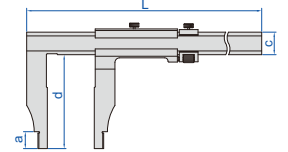
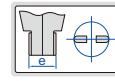

#### Graduation 0.05mm/1/128"

(mm)

Code	Range	Accuracy	a	c	d	e	L
1208-214	0-200mm/0-8"	±0.06mm	10	20	100	10	330
1208-394	0-300mm/0-12"	±0.07mm	10	20	90	10	410
1208-324	0-300mm/0-12"	±0.07mm	18	24	150	20	410
1208-524	0-500mm/0-20"	±0.08mm	18	24	150	20	670
1208-614	0-600mm/0-24"	±0.08mm	18	24	100	20	770
1208-824	0-800mm/0-32"	±0.09mm	24	31	150	20	1030
1208-1024	0-1000mm/0-40"	±0.12mm	24	31	150	20	1230

#### Graduation 0.02mm

(mm)

Code	Range	Accuracy	a	c	d	e	L
1208-521	0-500mm	±0.06mm	18	24	150	20	670
1208-1021	0-1000mm	±0.08mm	24	31	150	20	1230

### DEPTH BASE ATTACHMENTS

- To increase the stability of depth measurement
- Suitable for digital calipers and dial calipers
- Made of stainless steel



6140



6140-16B

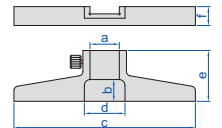

(mm)

Code	a	b	c	d	e	f	Type	Application
6140	16.5	9	75	18	30	6	narrow base (f=6)	Suitable for calipers with beam width (w) 16mm
6140-300A	20	15	125	22	34	9	narrow base (f=9)	Suitable for calipers with beam width (w) 20mm
6140-16B	16	12.5	75	24.5	30	11	wide base (f=11), high stability	Suitable for calipers with beam width (w) 16mm



### ACCESSORY SET FOR DIGITAL CALIPERS CODE 6144



6144

- Suitable for 0-150mm/0-6" and 0-200mm/0-8" digital calipers (thickness of lower jaws ≤ 3.7mm)

Code  
6144

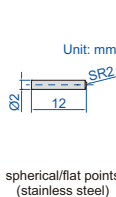
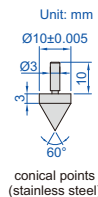
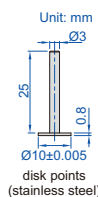
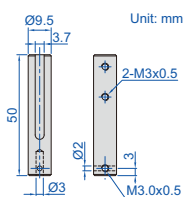

disk points (stainless steel)

conical points (stainless steel)

spherical/flat points (stainless steel)

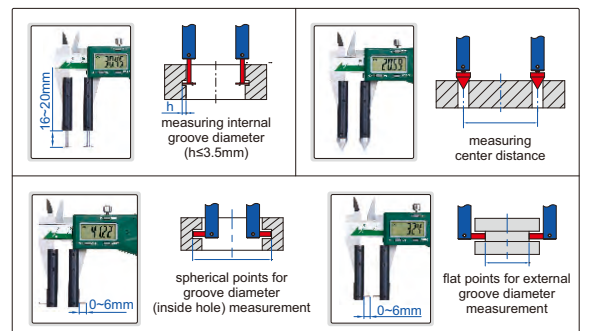

### ACCESSORY SET FOR LARGE DIGITAL CALIPERS CODE 6145-500



**Code**  
**6145-500**

■ Suitable for 0-500mm/0-20" and 0-600mm/0-24" digital calipers (thickness of lower jaws ≤ 5.6mm)

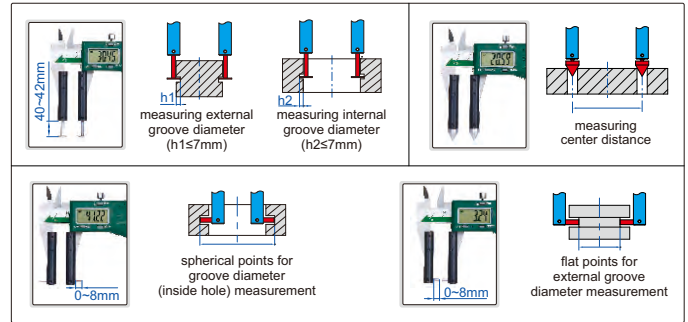
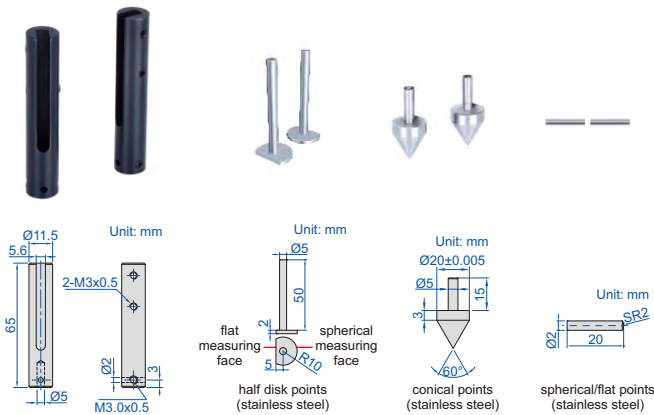

### ACCESSORY SET FOR LARGE DIGITAL CALIPERS (WITH SIDE POINTS) CODE 6146-500B



**Code**  
**6146-500B**

■ Suitable for 0-500mm/0-20" and 0-600mm/0-24" digital calipers (thickness of lower jaws ≤ 5.6mm)

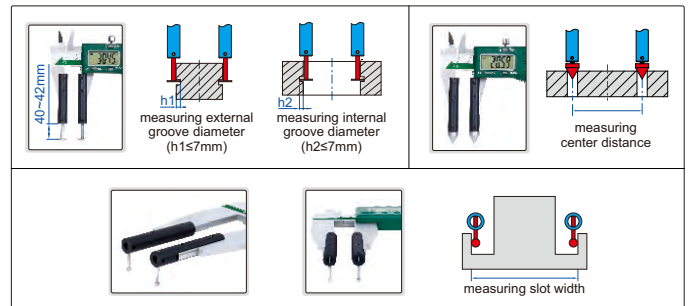
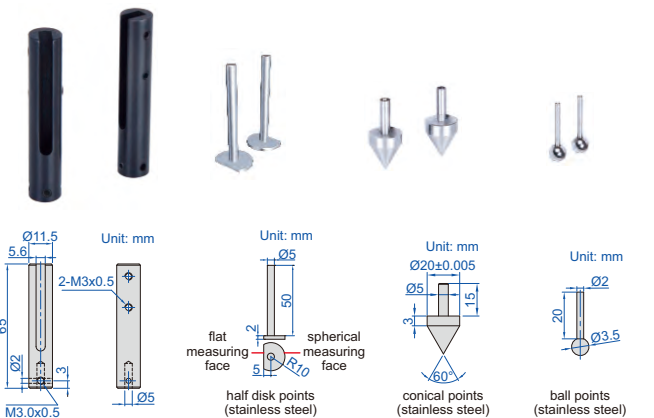

### DIGITAL CALIPER WITH INTERCHANGEABLE POINTS CODE 1526-200

**DATA OUTPUT**

short spherical points (included)

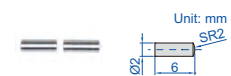

long spherical/flat points (included)



spherical blade points (included)

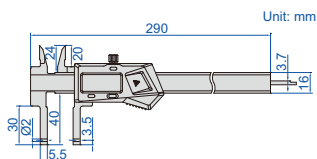
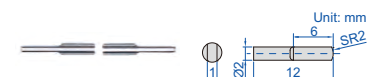

1526-200

- Non waterproof
- Supplied with 3 pairs of points and zero setting block for external measurement
- Resolution: 0.01mm/0.0005"
- Buttons: on/off, set, mm/inch, preset (+, -)
- Automatic power off, move the digital unit to turn on power
- Battery CR2032
- Data output
- Made of stainless steel
- Optional accessory: points, data output cable (code 7315-21 need receiver, 7302-21)

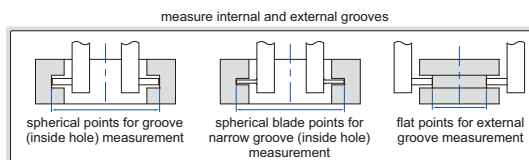

Point	Range	Accuracy	Application
short spherical points	12-212mm/0.5-8.5"(internal)	±0.03mm	for grooves inside small hole
long spherical/flat points	24-224mm/1-8.8"(internal) 0-187mm/0-7.5"(external)	±0.03mm	spherical points for grooves inside hole flat points for external grooves
spherical blade points	24-224mm/1-8.8"(internal) 0-187mm/0-7.5"(external)	±0.03mm	for narrow grooves inside hole

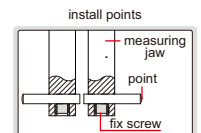
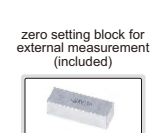

To be continued

Continued from previous page

### Depth stop (optional)

**Code**  
6143



6143

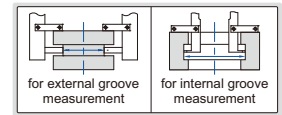
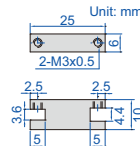

### Point sleeve (optional)



1526-T101

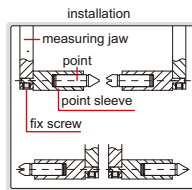
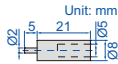

**Code**  
1526-T101

### Ball points (optional)



7391-T5



\* It is necessary to use point sleeve (code 1526-T101) for these points  
\*\* Range of 1526-200 after installing the points and point sleeve

Code	Ball dia. (D)	Range **
7391-T3 *	SØ2.0mm	75-275mm/3.0-10.8" (internal) 0-146mm/0-5.7" (external)
7391-T4 *	SØ2.5mm	76-276mm/3.0-10.8" (internal) 0-145mm/0-5.7" (external)
7391-T5 *	SØ3.0mm	77-277mm/3.0-10.9" (internal) 0-144mm/0-5.6" (external)
7391-T6 *	SØ3.5mm	78-278mm/3.1-10.9" (internal) 0-143mm/0-5.6" (external)
7391-T7 *	SØ4.0mm	79-279mm/3.1-10.9" (internal) 0-142mm/0-5.6" (external)
7391-T8 *	SØ4.5mm	80-280mm/3.2-11.0" (internal) 0-141mm/0-5.5" (external)
7391-T9 *	SØ5.0mm	81-281mm/3.2-11.0" (internal) 0-140mm/0-5.5" (external)
7391-T10 *	SØ6.0mm	83-283mm/3.3-11.1" (internal) 0-138mm/0-5.4" (external)

### Multifunctional points (optional)



7392-T1



7392-T2



7392-T3



7392-T4



7392-T5



7392-T6



7392-T7



7392-T8



7392-T9

Code	Type
7392-T1 *	flat
7392-T2 *	spherical
7392-T3 *	spline

Code	Type
7392-T4 *	disk
7392-T5 *	blade
7392-T6 *	knife-edge

Code	Type
7392-T7 *	point
7392-T8 *	knife-edge
7392-T9 *	point

Range **
66-266mm/2.6-10.5" (internal) 0-155mm/0-6.1" (external)

\* It is necessary to use point sleeve (code 1526-T101) for these points

\*\* Range of 1526-200 after installing the points and point sleeve

### Screw thread points (optional)



7321-T16



7381-T11

### Internal thread (60° thread angle)

Code	Pitch
7321-T11 *	0.4-0.5mm/64-48TPI
7321-T12 *	0.6-0.9mm/44-28TPI
7321-T13 *	1-1.75mm/24-14TPI
7321-T14 *	2-3mm/13-9TPI
7321-T15 *	3.5-5mm/8-5TPI
7321-T16 *	5.5-7mm/4.5-3.5TPI
7321-T1S *	6 pairs/set, including all above points

### External thread (60° thread angle)

Code	Pitch
7381-T11 *	0.4-0.5mm/64-48TPI
7381-T12 *	0.6-0.9mm/44-28TPI
7381-T13 *	1-1.75mm/24-14TPI
7381-T14 *	2-3mm/13-9TPI
7381-T15 *	3.5-5mm/8-5TPI
7381-T16 *	5.5-7mm/4.5-3.5TPI
7381-TS *	6 pairs/set, including all above points

Range **
66-266mm/2.6-10.5" (internal) 0-155mm/0-6.1" (external)

\* It is necessary to use point sleeve (code 1526-T101) for these points

\*\* Range of 1526-200 after installing the points and point sleeve

## DIGITAL CALIPER WITH INTERCHANGEABLE POINTS CODE 1124-300A

DATA  
OUTPUT

### short spherical/flat points (included)



### long spherical/flat points (included)



### short spherical blade points (included)

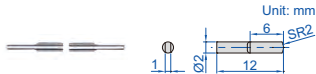

### long spherical blade points (included)

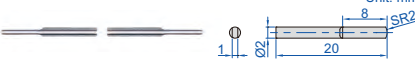

1124-300A

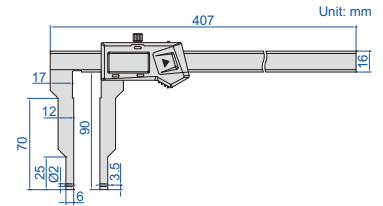

depth stop 6143  
(optional)



preset buttons



VIDEO

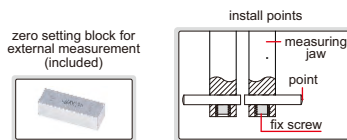

measure internal and external grooves

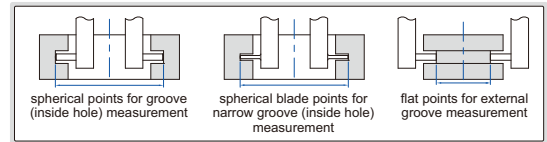

- Non waterproof
- Supplied with 4 pairs of points and zero setting block for external measurement
- Resolution: 0.01mm/0.0005"
- Buttons: on/off, set, mm/inch, preset (+, -)
- Automatic power off, move the digital unit to turn on power
- Battery CR2032
- Data output
- Made of stainless steel
- Optional accessory: points (code 1526-T101, 7392, 7391, 7381, 7321), depth stop (code 6143), data output cable (code 7315-21 need receiver, 7302-21)

Point	Range	Accuracy	Application
short spherical/flat points	24-324mm/1-12.7" (internal) 0-288mm/0-11.3" (external)	±0.04mm	spherical points for grooves inside hole (small hole) flat points for external grooves
long spherical/flat points	40-340mm/1.5-13.3" (internal) 0-272mm/0-10.7" (external)	±0.04mm	spherical points for grooves inside hole (large hole) flat points for external grooves
short spherical blade points	24-324mm/1-12.7" (internal) 0-288mm/0-11.3" (external)	±0.04mm	for narrow grooves inside hole (small hole)
long spherical blade points	40-340mm/1.5-13.3" (internal) 0-272mm/0-10.7" (external)	±0.04mm	for narrow grooves inside hole (large hole)

### Multifunctional points 7392\* (optional)

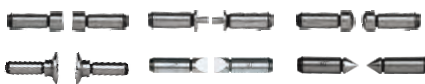

### Ball points 7391\* (optional)



### Screw thread points 7381\*, 7321\* (optional)



\*It is necessary to use point sleeve (code 1526-T101) for these points

## DIGITAL CALIPER WITH INTERCHANGEABLE POINTS

VARIOUS POINTS  
ARE AVAILABLE

DATA  
OUTPUT



VIDEO

preset buttons



depth stop 6143  
(optional)

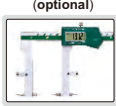

zero setting block for  
external measurement  
(included)



1530-300

measure internal and external grooves

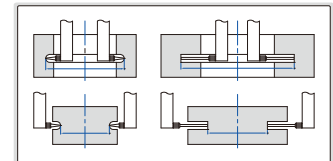

- Non waterproof
- Supplied with 4 pairs of points and zero setting block for external measurement
- Resolution: 0.01mm/0.0005"
- Buttons: on/off, set, mm/inch, preset (+, -)
- Automatic power off, move the digital unit to turn on power
- Battery CR2032
- Data output
- Made of stainless steel
- Optional accessory: points, depth stop (code 6143), data output cable (code 7315-21 need receiver, 7302-21)

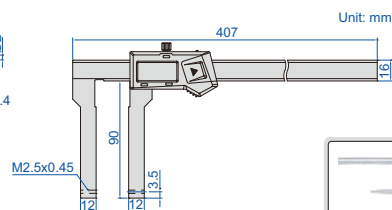
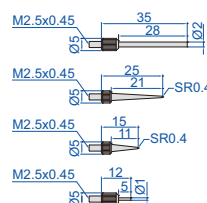

4 pairs of points (included)

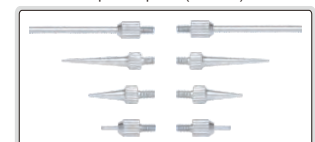

Code	Range*	Accuracy
1530-300	0-300mm/0-12"	±0.06mm

\*For different points, the measuring range changes accordingly

# UNIVERSAL CALIPER CODE 1125-600

DATA  
OUTPUT

- Non waterproof
- Buttons: on/off, set, mm/inch, ABS, preset (+, -)
- Automatic power off, move the digital unit to turn on power
- Battery CR2032
- Data output
- Made of stainless steel
- Optional accessory: data output cable (code 7315-22 need receiver, 7302-22)



1125-600

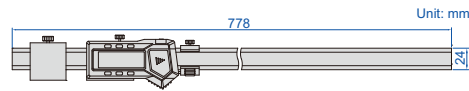

Code	Range*	Resolution	Accuracy
1125-600	0-600mm/0-24"	0.01mm/0.0005"	±0.05mm

\*The range changes according to different points

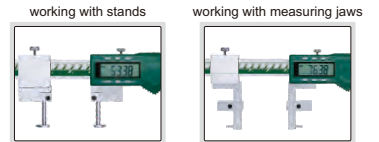

### Half disk points (included)

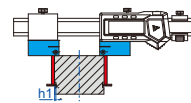
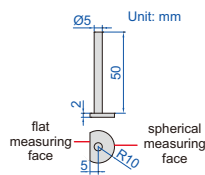

measuring external groove diameter with flat measuring face (depth  $h1 \leq 2.5\text{mm}$ )

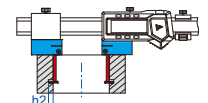

measuring internal groove diameter with spherical measuring face (depth  $h2 \leq 7.5\text{mm}$ )

### Round shoulder points (optional)

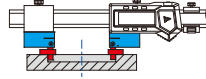
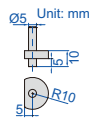

measure inside diameter of shallow hole

Code  
1125-T102

### Conical points (optional)

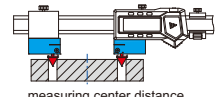
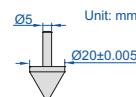

measuring center distance

Code  
1125-T101

### Spherical points (included)

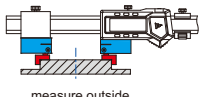
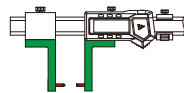
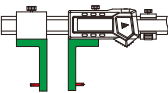
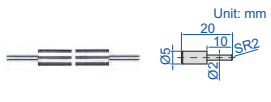

measure outside diameter of low boss

### Flat shoulder points (optional)

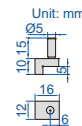

Code  
1125-T103

### Stands (included)

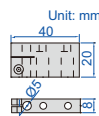

### Depth stop (included)

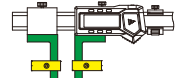
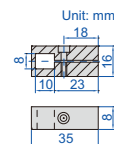

### Measuring jaws (included)

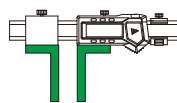
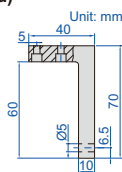

### Point sleeve (optional)

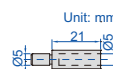

Code  
1125-T104

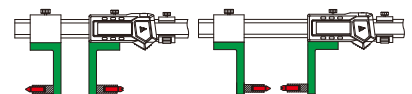

working with multifunctional points, ball points and screw thread points

### Multifunctional points 7392\* (optional)



### Ball points 7391\* (optional)



### Screw thread points 7381\*, 7321\* (optional)



\*It is necessary to use point sleeve (code 1125-T104) for these points

## DIGITAL INSIDE GROOVE CALIPERS

- Measure diameter of grooves inside small bores
- Resolution: 0.01mm/0.0005"
- Buttons type A: on/off, set, mm/inch, preset (+, -), type B: on/off, zero, mm/inch, ABS/REL, hold
- Battery CR2032
- Made of stainless steel
- Optional accessory: depth stop (code 6143)



1520-150

1520-150P

Non waterproof, with data interface (data output cable code 7315-21 need receiver, 7302-21, optional)

Code	Range	Type	Accuracy
1520-150	11-150mm/0.43-6"	A	±0.04mm

IP67 dust/waterproof, without data interface, no automatic power off, set zero after power on each time

Code	Range	Type	Accuracy
1520-150P	14-150mm/0.56-6"	B	±0.04mm

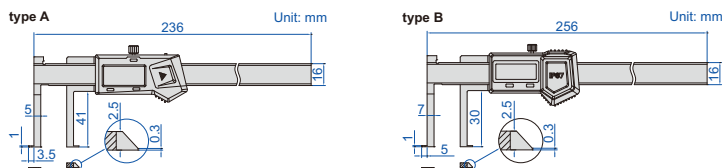

## DIGITAL INSIDE POINT CALIPERS



1121-150A

- Non waterproof
- Measure groove diameter
- Resolution: 0.01mm/0.0005"
- Buttons: on/off, set, mm/inch, preset (+, -)
- Automatic power off, move the digital unit to turn on power
- Battery CR2032, data output
- Made of stainless steel
- Optional accessory: depth stop (code 6143, for calipers with c=16mm)

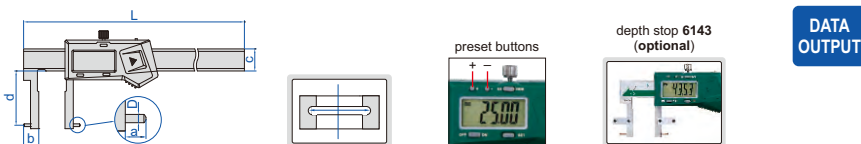

With data interface, preset (no need to add the width of the jaws on the reading)

(mm)

Code	Range	Accuracy	L	a	b	c	d	D	Data output cable (optional)
1121-150A	24-150mm/0.94-6"	±0.04mm	250	5	12	16	28	∅2	7315-21 need receiver, 7302-21
1121-1501	35-150mm/1.38-6"	±0.05mm	250	6	17.5	16	60	∅2	7315-21 need receiver, 7302-21
1121-200A	25-200mm/0.98-8"	±0.04mm	310	5	12.5	16	37	∅2	7315-21 need receiver, 7302-21
1121-2001	40-200mm/1.57-8"	±0.05mm	310	7	20	16	70	∅3	7315-21 need receiver, 7302-21
1121-300A	30-300mm/1.18-12"	±0.07mm	410	5	15	16	50	∅2	7315-21 need receiver, 7302-21
1121-3001A	50-300mm/1.97-12"	±0.07mm	410	8	25	16	77	∅3	7315-21 need receiver, 7302-21
1121-500A	40-500mm/1.57-20"	±0.07mm	680	5	20	24	90	∅3	7315-22 need receiver, 7302-22

## DIGITAL INSIDE GROOVE CALIPERS



1120-150A  
type A

1120-150P  
type C

- Measure groove diameter
- Resolution: 0.01mm/0.0005"
- Buttons type A: on/off, set, mm/inch, preset (+, -), type C: on/off, zero, mm/inch, ABS/REL, hold
- Battery CR2032
- Made of stainless steel
- Optional accessory: depth stop (code 6143, for calipers with c=16mm)

Non waterproof, with data interface, preset (no need to add the width of the jaws on the reading)

(mm)

Code	Range	Type	Accuracy	L	a	b	c	d	e	f	Data output cable (optional)
1120-150A	22-150mm/0.87-6"	A	±0.04mm	250	5	11	16	30	1	4	7315-21 need receiver, 7302-21
1120-1501	35-150mm/1.38-6"	A	±0.06mm	250	6	17.5	16	60	1.5	4	7315-21 need receiver, 7302-21
1120-200A	25-200mm/0.98-8"	A	±0.04mm	310	5	12.5	16	40	1	4	7315-21 need receiver, 7302-21
1120-2001	40-200mm/1.57-8"	A	±0.06mm	310	7	20	16	70	2.5	4	7315-21 need receiver, 7302-21
1120-300A	30-300mm/1.18-12"	A	±0.05mm	410	5	15	16	50	1.5	4	7315-21 need receiver, 7302-21
1120-3001	50-300mm/1.97-12"	A	±0.07mm	410	8	25	16	80	2.5	4	7315-21 need receiver, 7302-21
1120-500	40-500mm/1.57-20"	A	±0.07mm	680	5	20	24	90	2.2	5.5	7315-22 need receiver, 7302-22

IP67 dust/waterproof, without data interface, no automatic power off, set zero after power on each time, no preset (need to add the width of the jaws on the reading)

(mm)

Code	Range	Type	Accuracy	L	a	b	c	d	e	f
1120-150P	22-150mm/0.87-6"	C	±0.04mm	250	5	11	16	30	1	4

## INSIDE GROOVE VERNIER CALIPER

- Measure diameter of grooves inside bores
- Made of stainless steel
- Satin chrome plated reading surface



1262-150A

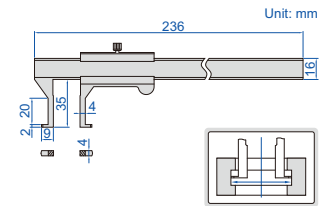

Code	Range	Graduation	Accuracy
1262-150A	18-150mm	0.02mm	±0.04mm

## DIGITAL INSIDE GROOVE CALIPERS

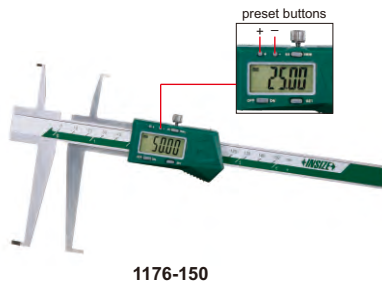

1176-150

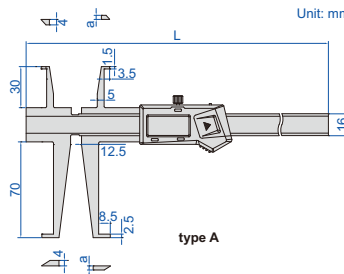

type A

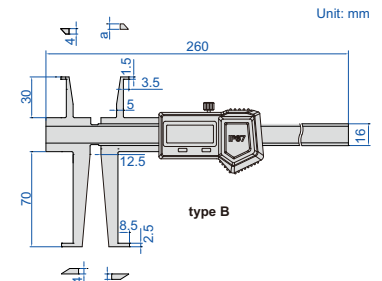

type B



1176-150P



depth stop 6143 (optional)

sizes to be measured (use upper jaws)

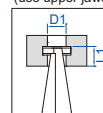

(mm)	
D1	L1
Ø9	<8
Ø10	<15
Ø11-200	<30

sizes to be measured (use lower jaws)

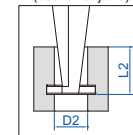

(mm)	
D2	L2
Ø17	<16
Ø18	<28
Ø19	<40
Ø20	<50
Ø21	<58
Ø22-200	<70

- Measure diameter of grooves inside bores
- Resolution: 0.01mm/0.0005"
- Buttons type A: on/off, set, mm/inch, preset (+, -), type B: on/off, zero, mm/inch, ABS/REL, hold
- Battery CR2032
- Made of stainless steel
- Optional accessory: depth stop (code 6143)

Non waterproof, with data interface  
(data output cable code 7315-21 need receiver, 7302-21, optional)

Code	Range of upper jaw	Range of lower jaw	Type	Accuracy	L	a
1176-150	9-150mm/0.35-6"	17-150mm/0.70-6"	A	±0.04mm	260mm	3mm
1176-200	9-200mm/0.35-8"	17-200mm/0.70-8"	A	±0.05mm	320mm	3.5mm

IP67 dust/waterproof, without data interface, no automatic power off, set zero after power on each time

Code	Range of upper jaw	Range of lower jaw	Type	Accuracy	a
1176-150P	9-150mm/0.35-6"	17-150mm/0.70-6"	B	±0.04mm	4mm

## INSIDE GROOVE CALIPERS

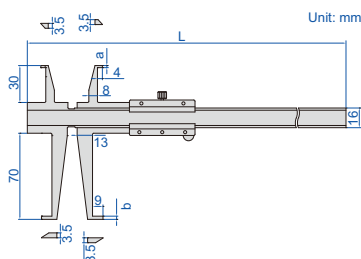

1199-150

sizes to be measured (use upper jaws)

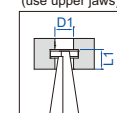

sizes to be measured (use lower jaws)

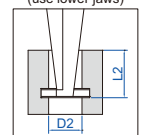

- Measure diameter of grooves inside bores
- Graduation: 0.02mm
- Made of stainless steel
- Optional accessory: depth stop (code 6143)

Code	Range of upper jaw	Range of lower jaw	Accuracy	L	(mm)		
					a	b	
1199-150	9-150mm	18-150mm	±0.04mm	248	1.6	2.5	
1199-200	9-200mm	18-200mm	±0.05mm	298	1.8	2.8	
1199-300	9-300mm	18-300mm	±0.06mm	398	2.0	3.0	

depth stop 6143 (optional)



(mm)	
D1	L1
Ø9	<8
Ø10	<12
Ø11	<15
Ø12	<20
Ø13-300	<30

(mm)	
D2	L2
Ø18	<30
Ø19	<40
Ø20	<45
Ø21	<55
Ø22	<60
Ø23-300	<70



## INSIDE GROOVE DIAL CALIPERS

**SHOCK PROOF**

- Measure diameter of grooves inside bores
- Shockproof dial indicator
- Dial indicator graduation: 0.02mm
- Made of stainless steel
- Optional accessory: depth stop (code 6143)



1376-150

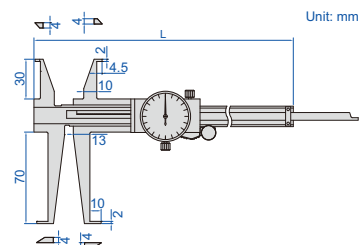

Unit: mm

Code	Range of upper jaw	Range of lower jaw	Accuracy	L
1376-150	11-150mm	18-150mm	±0.03mm	240mm
1376-200	11-200mm	18-200mm	±0.03mm	290mm
1376-300	11-300mm	18-300mm	±0.04mm	390mm

sizes to be measured (use upper jaws)

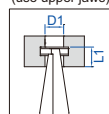

D1	L1
Ø11	<8
Ø12	<10
Ø13	<15
Ø14	<20
Ø15-300	<30

sizes to be measured (use lower jaws)

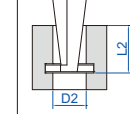

D2	L2
Ø18	<20
Ø19	<28
Ø20	<35
Ø21	<40
Ø22	<50
Ø23-300	<70

## DIGITAL DEEP HOLE INSIDE GROOVE CALIPER

**DATA OUTPUT**

- Non waterproof
- Measure diameter of grooves inside deep holes
- Resolution: 0.01mm/0.0005"
- Buttons: on/off, set, mm/inch, preset (+, -)
- Automatic power off, move the digital unit to turn on power
- Battery CR2032
- Data output
- Made of stainless steel
- Optional accessory: depth stop (code 6143), data output cable (code 7315-21 need receiver, 7302-21)



1129-300

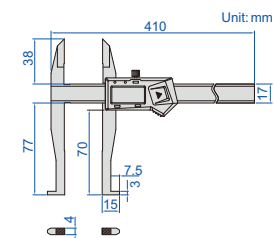

Unit: mm

preset buttons



depth stop 6143 (optional)

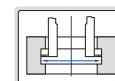

Code	Range of upper jaw	Range of lower jaw	Accuracy
1129-300	0-300mm/0-12"	30-300mm/1.2-12"	±0.06mm

## DIGITAL INSIDE GROOVE CALIPERS

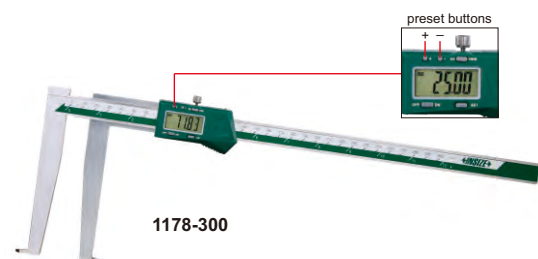

1178-300



1178-300P

preset buttons

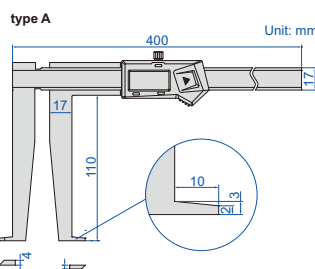

type A

Unit: mm

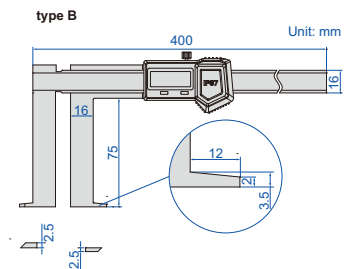

type B

Unit: mm

- Measure diameter of grooves inside bores
- Resolution: 0.01mm/0.0005"
- Buttons type A: on/off, set, mm/inch, preset (+, -), type B: on/off, zero, mm/inch, ABS/REL, hold
- Battery CR2032
- Made of stainless steel
- Optional accessory: depth stop (code 6143)

depth stop 6143 (optional)



Non waterproof, with data interface (data output cable code 7315-21 need receiver, 7302-21, optional)

Code	Range	Type	Accuracy
1178-300	25-300mm/1.18-12"	A	±0.05mm

IP67 dust/waterproof, without data interface, no automatic power off, set zero after power on each time

Code	Range	Type	Accuracy
1178-300P	33-300mm/1.30-12"	B	±0.05mm

## DIGITAL INSIDE GROOVE CALIPER

DATA OUTPUT

- Non waterproof
- Measure distance of grooves
- Resolution: 0.01mm/0.0005"
- Buttons: on/off, set, mm/inch, preset (+, -)
- Automatic power off, move the digital unit to turn on power
- Battery CR2032
- Data output
- Made of stainless steel
- Optional accessory: data output cable (code 7315-21 need receiver, 7302-21)



1128-200

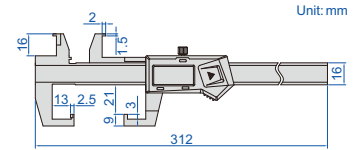

preset buttons

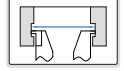
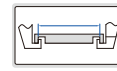

Code	Range of upper jaw	Range of lower jaw	Accuracy
1128-200	10-200mm/0.39-8"	3-200mm/0.12-8"	±0.03mm

## DIGITAL INSIDE GROOVE CALIPER

DATA OUTPUT

measure diameter of grooves 8-150mm

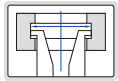

1191-150

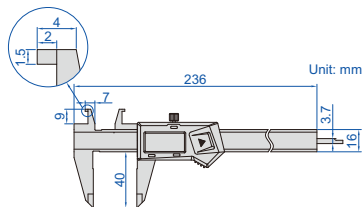

- Non waterproof
- Upper jaws for measuring diameter of grooves
- Resolution: 0.01mm/0.0005"
- Buttons: on/off, zero, mm/inch
- Automatic power off, move the digital unit to turn on power
- Battery CR2032, data output
- Made of stainless steel
- Optional accessory: data output cable (code 7315-21 need receiver, 7302-21)

Code	Range of upper jaw	Range of lower jaw	Accuracy
1191-150	8-150mm/0.3-6"	0-150mm/0-6"	±0.03mm

## INSIDE GROOVE VERNIER CALIPER

measure depth of grooves (h<10mm)



1291-150

measure diameter of grooves 8-150mm

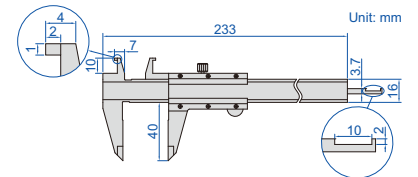
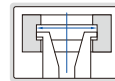

- Made of stainless steel
- Satin chrome plated reading surface

Code	Range of upper jaw	Range of lower jaw	Accuracy	Graduation
1291-150	8-150mm	0-150mm	±0.03mm	0.02mm

## DIGITAL OUTSIDE NECK CALIPER

DATA OUTPUT



1187-150A

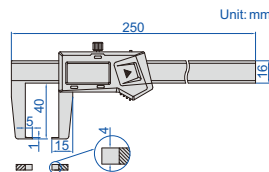

- Non waterproof
- Measure grooves and recesses
- Resolution: 0.01mm/0.0005"
- Buttons: on/off, zero, mm/inch
- Automatic power off, move the digital unit to turn on power
- Battery CR2032, data output
- Made of stainless steel
- Optional accessory: depth stop (code 6143), data output cable (code 7315-21 need receiver, 7302-21)

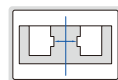

depth stop 6143 (optional)



Code	Range	Accuracy
1187-150A	0-150mm/0-6"	±0.04mm

## DIGITAL OUTSIDE POINT CALIPER

DATA OUTPUT



1185-150A

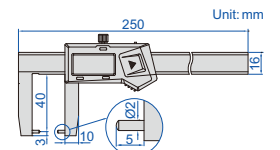

- Non waterproof
- Measure wall thickness inside bores and recesses
- Resolution: 0.01mm/0.0005"
- Buttons: on/off, zero, mm/inch
- Automatic power off, move the digital unit to turn on power
- Battery CR2032
- Data output
- Made of stainless steel
- Optional accessory: depth stop (code 6143), data output cable (code 7315-21 need receiver, 7302-21)

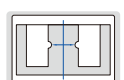

depth stop 6143 (optional)



Code	Range	Accuracy
1185-150A	0-150mm/0-6"	±0.04mm

## DEPTH STOP FOR CALIPERS

- Supplied in pairs
- Made of stainless steel
- Suitable for caliper series 1124, 1526, 1530, 1520, 1176, 1178, 1120, 1121, 1199, 1129, 1187 and 1185



6143

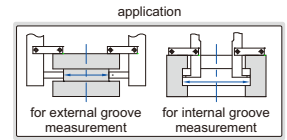
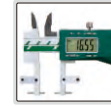
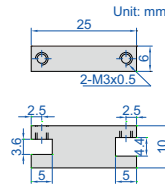

**Code**  
6143

## DIGITAL SMALL POINT CALIPER

DATA OUTPUT



1169-150

- Non waterproof
- Small pointed jaws fit into small grooves and recesses
- Resolution: 0.01mm/0.0005"
- Buttons: on/off, zero, mm/inch
- Automatic power off, move the digital unit to turn on power
- Battery CR2032, data output
- Made of stainless steel
- Optional accessory: data output cable (code 7315-21 need receiver, 7302-21)

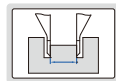
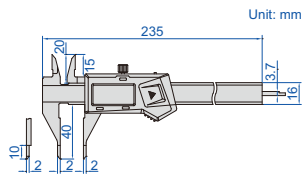

Code	Range	Accuracy
1169-150	0-150mm/0-6"	±0.03mm

## DIGITAL POINT CALIPER

DATA OUTPUT



1183-150A

- Non waterproof
- Pointed jaws fit into small grooves and recesses
- Resolution: 0.01mm/0.0005"
- Buttons: on/off, zero, mm/inch
- Automatic power off, move the digital unit to turn on power
- Battery CR2032, data output
- Made of stainless steel
- Optional accessory: data output cable (code 7315-21 need receiver, 7302-21)

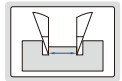
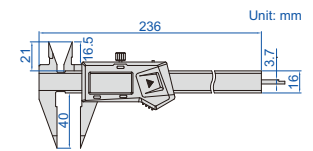

Code	Range	Accuracy
1183-150A	0-150mm/0-6"	±0.03mm

## DIGITAL BLADE CALIPER

DATA OUTPUT



1188-150A

- Non waterproof
- The blade jaws fit into small grooves
- Resolution: 0.01mm/0.0005"
- Buttons: on/off, zero, mm/inch
- Automatic power off, move the digital unit to turn on power
- Battery CR2032, data output
- Made of stainless steel
- Optional accessory: data output cable (code 7315-21 need receiver, 7302-21)

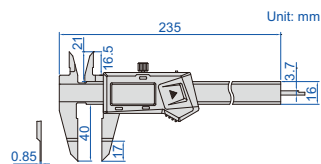

Code	Range	Accuracy
1188-150A	0-150mm/0-6"	±0.03mm

## DIGITAL INSIDE KNIFE-EDGE CALIPER

DATA OUTPUT



1123-150A

- Non waterproof
- Measure diameter of deep step holes
- Resolution: 0.01mm/0.0005"
- Buttons: on/off, zero, mm/inch
- Automatic power off, move the digital unit to turn on power
- Battery CR2032, data output
- Made of stainless steel
- Optional accessory: data output cable (code 7315-21 need receiver, 7302-21)

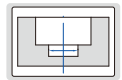
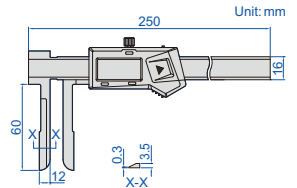

Code	Range	Accuracy
1123-150A	15-150mm/0.6-6"	±0.05mm

## DIGITAL CALIPER WITH KNIFE-EDGE LOWER JAWS

DATA OUTPUT

- Non waterproof
- Measure diameter of narrow grooves
- Resolution: 0.01mm/0.0005"
- Buttons: on/off, zero, mm/inch
- Automatic power off, move the digital unit to turn on power
- Battery CR2032
- Data output
- Made of stainless steel
- Optional accessory: data output cable (code 7315-21 need receiver, 7302-21)



1532-200

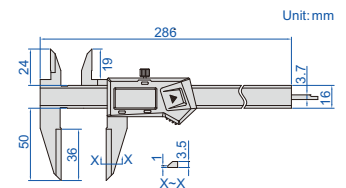
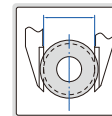

Code	Range	Accuracy
1532-200	0-200mm/0-8"	±0.03mm

## DIGITAL CALIPER WITH LONG UPPER JAWS

DATA OUTPUT



1138-200

- Non waterproof
- Long upper jaws for measuring diameter of deep holes
- Resolution: 0.01mm/0.0005"
- Buttons: on/off, zero, mm/inch
- Automatic power off, move the digital unit to turn on power
- Battery CR2032
- Data output
- Made of stainless steel
- Optional accessory: data output cable (code 7315-21 need receiver, 7302-21)

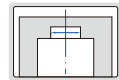
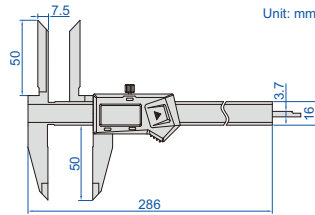

Code	Range	Accuracy
1138-200	0-200mm/0-8"	±0.04mm

## DIGITAL OFFSET CENTERLINE CALIPER

DATA OUTPUT



1192-150A

- Non waterproof
- Measure hole center distance in the same or offset planes
- Resolution: 0.01mm/0.0005"
- Buttons: on/off, set, mm/inch, preset (+, -)
- Automatic power off, move the digital unit to turn on power
- Battery CR2032, data output
- Made of stainless steel
- Optional accessory: data output cable (code 7315-21 need receiver, 7302-21)

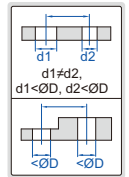
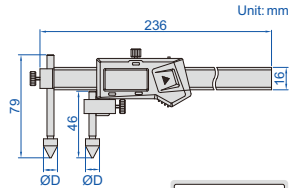

Code	Range	Accuracy	$\varnothing D$
1192-150A	10-150mm/0.4-6"	±0.05mm	10mm

## DIGITAL CENTERLINE AND EDGE TO CENTER CALIPERS

DATA OUTPUT

- Non waterproof
- Measure hole center distance or edge to hole center distance
- Resolution: 0.01mm/0.0005"
- Buttons: on/off, set, mm/inch, preset (+, -)
- Automatic power off, move the digital unit to turn on power
- Battery CR2032
- Data output
- Made of stainless steel



1525-300

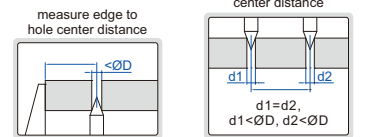
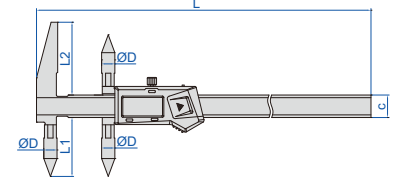

Code	Range of upper jaw (edge to center)	Range of lower jaw (center to center)	Accuracy	$\varnothing D$	L1	L2	c	L	Data output cable (optional)
1525-300	5-300mm/0.2-12"	10-300mm/0.4-12"	±0.08mm	10mm	44.5mm	55mm	17mm	410mm	7315-21 need receiver, 7302-21
1525-500	10-500mm/0.4-20"	20-50mm/0.8-20"	±0.09mm	20mm	50mm	60mm	24mm	690mm	7315-22 need receiver, 7302-22
1525-1000	15-1000mm/0.6-40"	30-1000mm/1.2-40"	±0.12mm	30mm	70mm	81mm	31mm	1255mm	7315-22 need receiver, 7302-22
1525-1500	15-1500mm/0.6-60"	30-1500mm/1.2-60"	±0.15mm	30mm	70mm	81mm	31mm	1760mm	7315-22 need receiver, 7302-22

## DIGITAL CENTERLINE AND EDGE TO CENTER CALIPERS

DATA OUTPUT

- Non waterproof
- Measure hole center distance in the same or offset planes and edge to hole center distance
- Resolution: 0.01mm/0.0005"
- Buttons: on/off, set, mm/inch, preset (+, -)
- Automatic power off, move the digital unit to turn on power
- Battery CR2032, data output
- Made of stainless steel
- Optional accessory: data output cable (code 7315-21 need receiver, 7302-21)



1521-2002

Code	Range	Accuracy	$\varnothing D$	L	c	d
1521-150	5-150mm/0.2-6"	±0.05mm	5mm	236mm	16mm	5mm
1521-1501	10-150mm/0.4-6"	±0.05mm	10mm	236mm	16mm	10mm
1521-1502	20-150mm/0.8-6"	±0.05mm	20mm	236mm	16mm	20mm
1521-200	5-200mm/0.2-8"	±0.05mm	5mm	285mm	16mm	5mm
1521-2001	10-200mm/0.4-8"	±0.05mm	10mm	285mm	16mm	10mm
1521-2002	20-200mm/0.8-8"	±0.05mm	20mm	285mm	16mm	20mm
1521-300	5-300mm/0.2-12"	±0.07mm	5mm	385mm	17mm	5mm
1521-3001	10-300mm/0.4-12"	±0.07mm	10mm	385mm	17mm	10mm
1521-3002	20-300mm/0.8-12"	±0.07mm	20mm	385mm	17mm	20mm

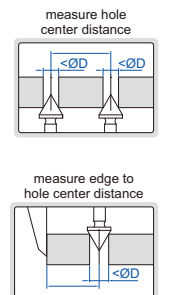
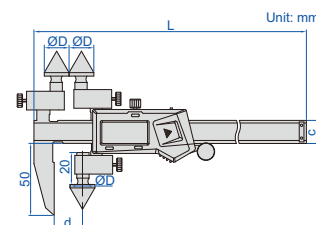

## DIGITAL BACK-JAW CENTERLINE CALIPERS

DATA OUTPUT

- Non waterproof
- Measure hole center distance in the same or offset planes
- Resolution: 0.01mm/0.0005"
- Buttons: on/off, set, mm/inch, preset (+, -)
- Automatic power off, move the digital unit to turn on power
- Battery CR2032
- Data output
- Made of stainless steel

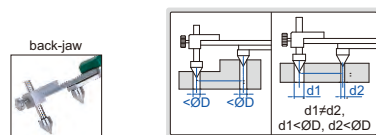
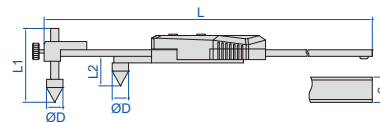
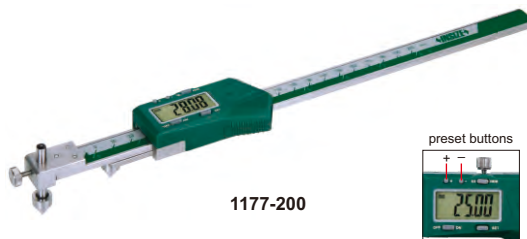

Code	Range	Accuracy	ØD	c	L1	L2	L	Data output cable (optional)
1177-200	10-200mm/0.4-8"	±0.10mm	10	16	18	45	310	7315-21 need receiver, 7302-21
1177-300	10-300mm/0.4-12"	±0.10mm	10	16	18	45	410	7315-21 need receiver, 7302-21
1177-500	20-500mm/0.8-20"	±0.10mm	20	24	26	70	692	7315-22 need receiver, 7302-22
1177-1000	30-1000mm/1.2-40"	±0.12mm	30	31	39	70	1242	7315-22 need receiver, 7302-22
1177-1500	30-1500mm/1.2-60"	±0.15mm	30	31	39	70	1745	7315-22 need receiver, 7302-22

## DIGITAL BACK-JAW EDGE TO CENTER CALIPERS

DATA OUTPUT

- Non waterproof
- Measure edge to hole center distance
- Resolution: 0.01mm/0.0005"
- Buttons: on/off, set, mm/inch, preset (+, -)
- Automatic power off, move the digital unit to turn on power
- Battery CR2032
- Data output
- Made of stainless steel
- Optional accessory: data output cable (code 7315-21 need receiver, 7302-21)



Code	Range	Accuracy	L
1524-200	5-200mm/0.2-8"	±0.1mm	310mm
1524-300	5-300mm/0.2-12"	±0.1mm	410mm

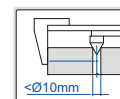
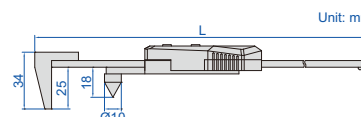

## DIGITAL HOOK CALIPER

DATA OUTPUT

- Non waterproof
- Measure width and distance of grooves inside bores
- Resolution: 0.01mm/0.0005"
- Buttons: on/off, zero, mm/inch
- Automatic power off, move the digital unit to turn on power
- Battery CR2032, data output
- Made of stainless steel
- Optional accessory: data output cable (code 7315-21 need receiver, 7302-21)



1122-300

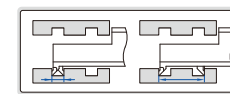
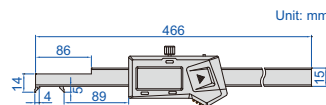

Code	Range	Accuracy
1122-300	4-300mm/0.16-12"	±0.04mm

## DIGITAL OFFSET CALIPERS

DATA OUTPUT

- Non waterproof
- The left jaw can slide up and down to facilitate measurement of stepped sections
- Resolution: 0.01mm/0.0005"
- Buttons: on/off, zero, mm/inch
- Automatic power off, move the digital unit to turn on power
- Battery CR2032, data output
- Made of stainless steel
- Optional accessory: data output cable (code 7315-21 need receiver, 7302-21)



1186-150A

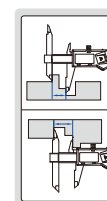
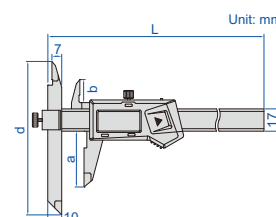

Code	Range	Accuracy	L	a	b	d
1186-150A	0-150mm/0-6"	±0.04mm	249	40	16.5	110
1186-300A	0-300mm/0-12"	±0.05mm	399	60	20.5	130

## DIGITAL TUBE THICKNESS CALIPER

DATA  
OUTPUT

- Non waterproof
- Measure wall thickness of tubes
- Resolution: 0.01mm/0.0005"
- Buttons: on/off, zero, mm/inch
- Automatic power off, move the digital unit to turn on power
- Battery CR2032, data output
- Made of stainless steel
- Optional accessory: data output cable (code 7315-21 need receiver, 7302-21)



1161-150A

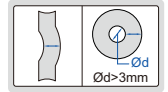
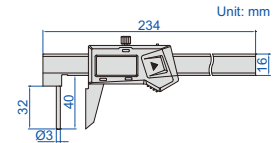

Code	Range	Accuracy
1161-150A	0-150mm/0-6"	±0.05mm

## DIGITAL RTJ RING GROOVE CALIPERS

DATA  
OUTPUT

- Non waterproof
- Measure ring grooves of flange
- Resolution: 0.01mm/0.0005"
- Button function: on/off, set, zero, mm/inch, data preset
- Battery CR2032, data output
- Made of stainless steel



1179-300  
type A



1179-600  
type B

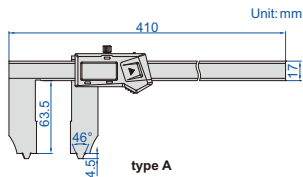

type A

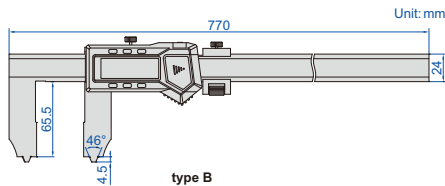

type B

measure outside diameter  
of RTJ ring groove

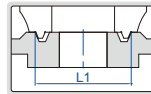

measure inside diameter  
of RTJ ring groove

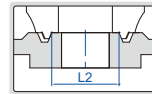

applicable for RTJ ring  
grooves with angle 23°

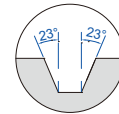

10mm and 25mm need to  
be added on the reading

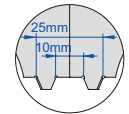

Code	Range (inside diameter of RTJ ring groove)	Range (outside diameter of RTJ ring groove)	Angle of RTJ ring groove	Accuracy	Type	Data output cable (optional)
1179-300	10-300mm/0.4-12"	25-300mm/1-12"	23°	±0.06mm	A	7315-21 need receiver, 7302-21
1179-600	10-600mm/0.4-24"	25-600mm/1-24"	23°	±0.07mm	B	7315-22 need receiver, 7302-22

## DIGITAL CALIPER WITH INTERCHANGEABLE BALL TIPS

DATA  
OUTPUT

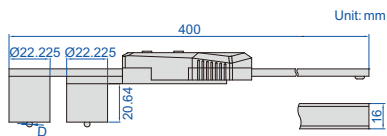

1527-3001

- Non waterproof
- Resolution 0.01mm/.0005"
- Buttons: on/off, set, mm/inch, preset (+, -)
- Automatic power off, move the digital unit to turn on power
- Battery CR2032, data output
- Made of stainless steel
- Optional accessory: ball tips, data output cable (code 7315-21 need receiver, 7302-21)

Code	Range	Accuracy
1527-3001	(22.22+D)~300mm*	±0.03mm

\*"D" is the diameter of ball tips.

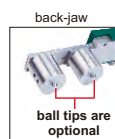

Ball tips (optional, supplied in pair)

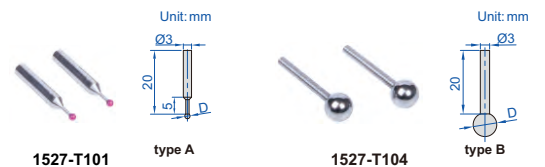

1527-T101

type A

1527-T104

type B

Code	Diameter (D)	Accuracy of diameter	Type	Material
1527-T101	1/16" (Ø1.5875mm)	±0.005mm	A	ruby
1527-T102	1/8" (Ø3.175mm)	±0.005mm	B	stainless steel
1527-T103	3/16" (Ø4.7625mm)	±0.005mm	B	stainless steel
1527-T104	1/4" (Ø6.35mm)	±0.005mm	B	stainless steel
1527-T105	3/8" (Ø9.525mm)	±0.005mm	B	stainless steel
1527-T106	1/2" (Ø12.7mm)	±0.005mm	B	stainless steel

## DIGITAL CALIPER WITH INTERCHANGEABLE BALL TIPS

DATA OUTPUT



ball tips are optional

1528-3001

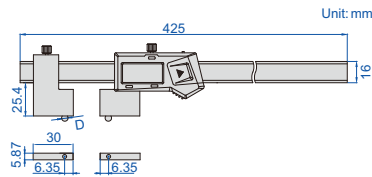

- Non waterproof
- Resolution 0.01mm/0.0005"
- Buttons: on/off, set, mm/inch, preset (+, -)
- Automatic power off, move the digital unit to turn on power
- Battery CR2032, data output
- Made of stainless steel
- Optional accessory: ball tips, data output cable (code 7315-21 need receiver, 7302-21)

Code	Range	Accuracy
1528-3001	(12.7+D)~300mm*	±0.03mm



\*"D" is the diameter of ball tips.

Ball tips (optional, supplied in pair)

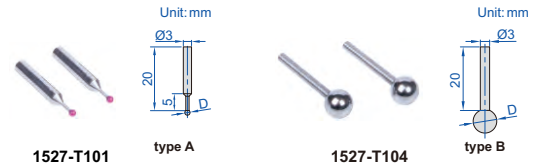

Code	Diameter (D)	Accuracy of diameter	Type	Material
1527-T101	1/16" (Ø1.5875mm)	±0.005mm	A	ruby
1527-T102	1/8" (Ø3.175mm)	±0.005mm	B	stainless steel
1527-T103	3/16" (Ø4.7625mm)	±0.005mm	B	stainless steel
1527-T104	1/4" (Ø6.35mm)	±0.005mm	B	stainless steel
1527-T105	3/8" (Ø9.525mm)	±0.005mm	B	stainless steel
1527-T106	1/2" (Ø12.7mm)	±0.005mm	B	stainless steel

## DIGITAL CRIMP HEIGHT CALIPER

DATA OUTPUT

- Non waterproof
- Measure crimp height
- Resolution: 0.01mm/0.0005"
- Buttons: on/off, zero, mm/inch
- Automatic power off, move the digital unit to turn on power
- Battery CR2032
- Data output
- Meet DIN862
- Made of stainless steel
- Optional accessory: data output cable (code 7315-21 need receiver, 7302-21)



1165-150A

Code	Range	Accuracy
1165-150A	0-150mm/0-6"	±0.03mm

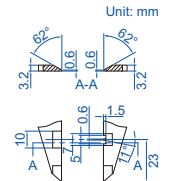
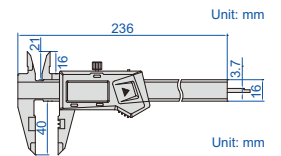

## DIGITAL CALIPER WITH LARGE MEASURING FACES

DATA OUTPUT

- Non waterproof
- Measure diameter of wire ropes, and thickness of soft materials like rubber, sponge, etc.
- Resolution: 0.01mm/0.0005"
- Buttons: on/off, zero, mm/inch
- Automatic power off, move the digital unit to turn on power
- Battery CR2032
- Data output
- Made of stainless steel
- Optional accessory: data output cable (code 7315-21 need receiver, 7302-21)



1172-200

Code	Range	Accuracy
1172-200	0-200mm/0-8"	±0.07mm

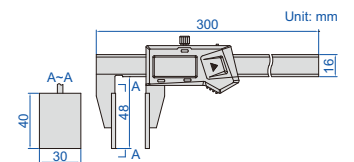

measure diameter of wire ropes

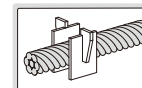

measure thickness of rubber, sponge, etc.



## DIGITAL CALIPER WITH DISK FACES

DATA OUTPUT

- Non waterproof
- Measure thickness of soft sheets
- Resolution: 0.01mm/0.0005"
- Buttons: on/off, zero, mm/inch
- Automatic power off, move the digital unit to turn on power
- Battery CR2032
- Made of stainless steel
- Optional accessory: data output cable (code 7315-21 need receiver, 7302-21)



1533-150

Code	Range	Accuracy
1533-150	0-150mm/0-6"	±0.04mm

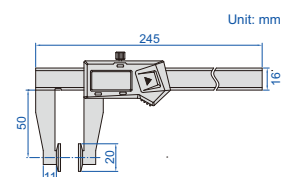
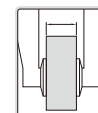

## DIGITAL WALL THICKNESS CALIPER

- Non waterproof
- Measure wall thickness of helmets, domes and curved pots
- Resolution: 0.01mm/0.0005"
- Buttons: on/off, zero, mm/inch, ABS, data preset
- Automatic power off, move the digital unit to turn on power
- Battery CR2032
- Data output
- Made of stainless steel
- Optional accessory: data output cable (code 7315-22 need receiver, 7302-22)

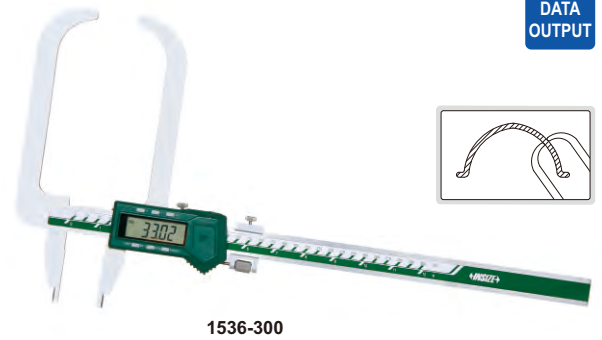
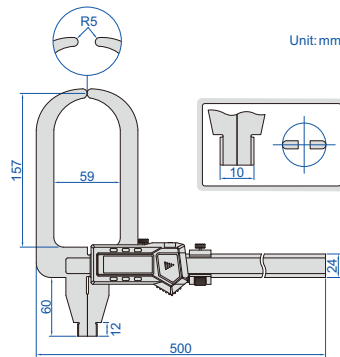

1536-300

Code	Range	Accuracy
1536-300	0-300mm/0-12"	±0.05mm

## DIGITAL V SHAPE CALIPER

DIRECT READING,  
CALCULATION IS NOT REQUIRED



1539-3

DATA  
OUTPUT

- Non waterproof
- Measure outside diameter of three number of flutes (such as taps, reamers, end mills and gears)
- Resolution: 0.01mm/0.0005"
- Buttons: on/off, zero, mm/inch
- Battery CR2032
- Automatic power off, move the digital unit to turn on power
- Data output
- Made of stainless steel
- Optional accessory: data output cable (code 7315-21 need receiver, 7302-21)

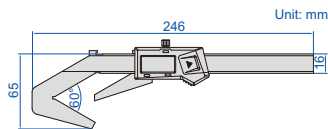

Code	Range	Accuracy
1539-3	Ø4-Ø40mm/0.16"-1.58" DIA	±0.03mm

## V SHAPE VERNIER CALIPER



1273-403

- Measure outside diameter of three number of flutes (such as taps, reamers, end mills and gears)
- Made of stainless steel
- Satin chrome plated reading surface

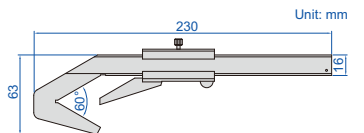

Code	Range	Graduation	Accuracy
1273-403	Ø4-40mm	0.05mm	±0.05mm

## DIGITAL GEAR TOOTH CALIPERS

ATTENTION:  
NO DATA OUTPUT

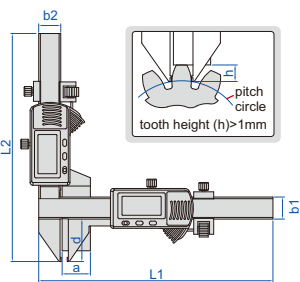

1181-M25A

- Non waterproof
- Resolution: 0.01mm/0.0005"
- Accuracy of height measurement: ±0.03mm
- Accuracy of thickness measurement: ±0.03mm
- Carbide tips
- Measure the tooth thickness by positioning the tooth height (for tooth height > 1mm)
- Buttons: zero, on/off, mm/inch
- Automatic power off, move the digital unit to turn on power
- Battery CR2032
- Made of stainless steel

(mm)

Code	Range	Total accuracy	L1	L2	a	b1	b2	d
1181-M25A	M1-25mm	±0.04mm	170	165.5	21	16	16	30.5
1181-M50A	M5-50mm	±0.04mm	220	190	50.5	16	16	55

## GEAR TOOTH VERNIER CALIPER

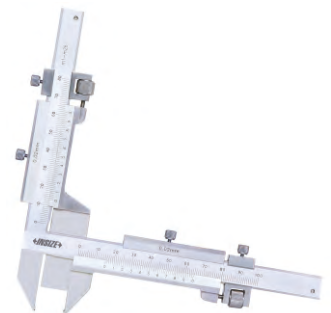
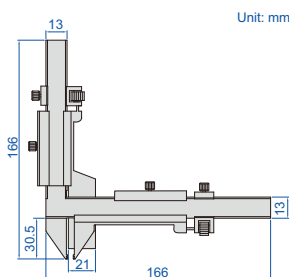

1281-M26A

- Graduation: 0.02mm
- Total accuracy: ±0.04mm
- Carbide tips
- Measure the tooth thickness by positioning the tooth height (for tooth height > 1mm)
- Made of stainless steel
- Satin chrome plated reading surface

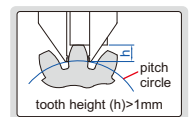

Code	Range	Accuracy of height measurement	Accuracy of thickness measurement
1281-M26A	M1-26mm	±0.03mm	±0.03mm



### DIGITAL DISK BRAKE CALIPER

DATA OUTPUT



1162-125A

- Non waterproof
- Measure thickness of disk brakes
- Resolution 0.01mm/0.0005"
- Buttons: on/off, zero, mm/inch
- Automatic power off, move the digital unit to turn on power
- Battery CR2032, data output
- Made of stainless steel
- Optional accessory: data output cable (code 7315-21 need receiver, 7302-21)

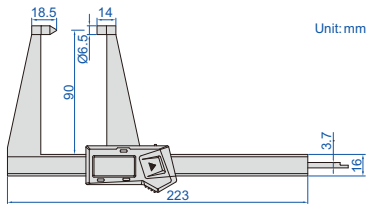

Code	Range	Accuracy
1162-125A	0-125mm/0-5"	±0.05mm

### DIGITAL DISK BRAKE AND PAD CALIPER

DATA OUTPUT



1167-150A

- Non waterproof
- Measure thickness of disk brakes and pad wear
- Resolution: 0.01mm/0.0005"
- Buttons: on/off, zero, mm/inch
- Automatic power off, move the digital unit to turn on power
- Battery CR2032, data output
- Made of stainless steel
- Optional accessory: data output cable (code 7315-21 need receiver, 7302-21)

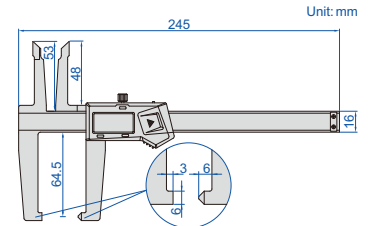

Code	Range	Accuracy
1167-150A	0-150mm/0-6"	±0.07mm



### DIGITAL DRUM BRAKE CALIPER

DATA OUTPUT

- Non waterproof
- Measure internal and external diameter of drum brakes
- Resolution 0.01mm/0.0005"
- Buttons: on/off, zero, mm/inch
- Automatic power off, move the digital unit to turn on power
- Battery CR2032, data output
- Made of stainless steel
- Optional accessory: data output cable (code 7315-21 need receiver, 7302-21)



1168-300A

Code	Range	Accuracy
1168-300A	0-300mm/0-12"	±0.07mm

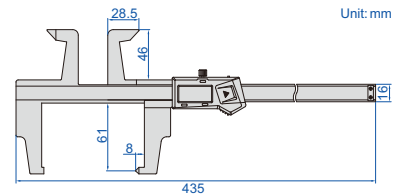

### DIGITAL DRUM BRAKE CALIPER

DATA OUTPUT

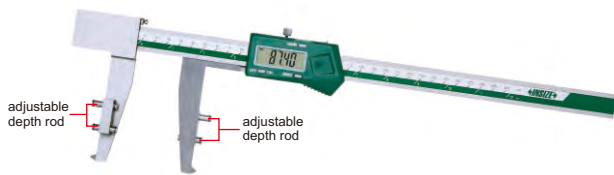

1538-300

- Non waterproof
- Measure internal diameter of drum brakes
- Resolution: 0.01mm/0.0005"
- Buttons: on/off, zero, mm/inch
- Automatic power off, move the digital unit to turn on power
- Battery CR2032
- Data output
- Made of stainless steel
- Optional accessory: data output cable (code 7315-22 need receiver, 7302-22)

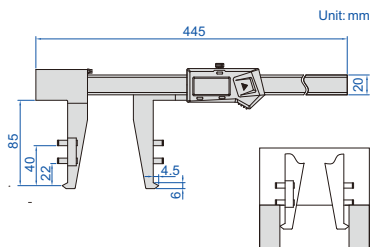

calibration block (included)



Code	Range	Accuracy
1538-300	30-300mm/1.2-12"	±0.05mm

### IP67 WATERPROOF DIGITAL DEPTH GAGES

IP67 WATERPROOF

ATTENTION: NO DATA OUTPUT

ATTENTION: IT IS NECESSARY TO SET ZERO AFTER POWER ON EACH TIME



1149-150

- IP67 dust/waterproof
- Resolution: 0.01mm/0.0005"
- Button function: zero, on/off, mm/inch, ABS/REL, hold
- Meet DIN862
- Battery CR2032
- Made of stainless steel

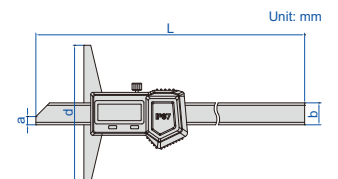

Code	Range	Accuracy	L	a	b	d
1149-150	0-150mm/0-6"	±0.03mm	240	6	16	100
1149-200	0-200mm/0-8"	±0.03mm	290	6	16	100
1149-300	0-300mm/0-12"	±0.03mm	390	6	16	150

## IP67 WATERPROOF DIGITAL DEPTH GAGES

ATTENTION: NO DATA OUTPUT

IP67 WATERPROOF

- IP67 dust/waterproof
- Resolution: 0.01mm/0.0005"
- Button function: zero, on/off, mm/inch
- Battery CR2032
- Automatic power off
- Meet DIN862
- Made of stainless steel



1543-150

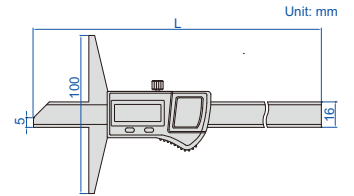

Code	Range	Accuracy	L
1543-150	0-150mm/0-6"	±0.03mm	235mm
1543-200	0-200mm/0-8"	±0.03mm	285mm
1543-300	0-300mm/0-12"	±0.03mm	387mm

## DIGITAL DEPTH GAGES (STANDARD TYPE)

POPULAR MODEL

DATA OUTPUT

- Non waterproof
- Resolution: 0.01mm/0.0005"
- Buttons: on/off, zero, mm/inch
- Automatic power off, move the digital unit to turn on power
- Meet DIN862 (except 0-500mm/0-20")
- Battery CR2032, data output
- Made of stainless steel



1141-150A

(mm)

Code	Range	Accuracy	L	a	b	d	Data output cable (optional)
1141-150A	0-150mm/0-6"	±0.03mm	230	6	14.5	100	7315-21 need receiver, 7302-21
1141-200A	0-200mm/0-8"	±0.03mm	280	6	14.5	100	7315-21 need receiver, 7302-21
1141-300A	0-300mm/0-12"	±0.03mm	380	6	14.5	150	7315-21 need receiver, 7302-21
1141-500A	0-500mm/0-20"	±0.05mm	585	7	15	150	7315-22 need receiver, 7302-22

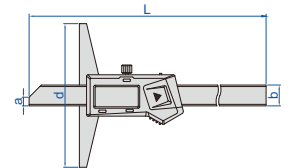

## DIGITAL DEPTH GAGES WITH MOUNTING HOLES FOR EXTENSION BASE

DATA OUTPUT

- Non waterproof
- Resolution: 0.01mm/0.0005"
- Buttons: on/off, zero, mm/inch
- Automatic power off, move the digital unit to turn on power
- Meet DIN862
- Battery CR2032, data output
- Made of stainless steel
- Optional accessory: data output cable (code 7315-21 need receiver, 7302-21), extension base (code 6141)



1147-300

extension base (optional)

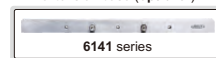

6141 series

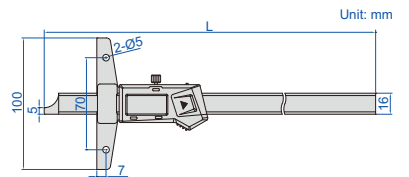

Code	Range	Accuracy	L
1147-150	0-150mm/0-6"	±0.03mm	237mm
1147-200	0-200mm/0-8"	±0.03mm	287mm
1147-300	0-300mm/0-12"	±0.03mm	403mm

## DIGITAL HOOK DEPTH GAGES

DATA OUTPUT

- Non waterproof
- Resolution: 0.01mm/0.0005"
- Buttons: on/off, zero, mm/inch
- Automatic power off, move the digital unit to turn on power
- Battery CR2032, data output
- Made of stainless steel
- Optional accessory: data output cable (code 7315-21 need receiver, 7302-21)



1142-150A

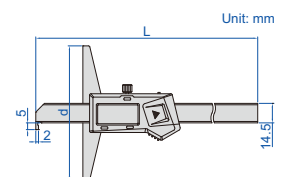

Code	Range	Accuracy	L	d
1142-150A	0-150mm/0-6"	±0.03mm	230mm	100mm
1142-200A	0-200mm/0-8"	±0.03mm	280mm	100mm

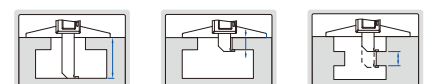

## DIGITAL DOUBLE HOOK DEPTH GAGES

DATA OUTPUT

- Non waterproof
- Resolution: 0.01mm/0.0005"
- Buttons: on/off, zero, mm/inch
- Automatic power off, move the digital unit to turn on power
- Meet DIN862
- Battery CR2032
- Data output
- Made of stainless steel
- Optional accessory: data output cable (code 7315-21 need receiver, 7302-21)



1144-150A

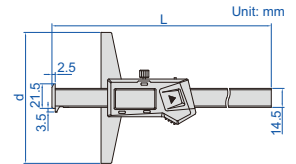

Code	Range	Accuracy	L	d
1144-150A	0-150mm/0-6"	±0.03mm	233mm	100mm
1144-200A	0-200mm/0-8"	±0.03mm	283mm	100mm
1144-300A	0-300mm/0-12"	±0.03mm	383mm	150mm



## DIGITAL POINT DEPTH GAGE

DATA OUTPUT

- Non waterproof
- Resolution: 0.01mm/0.0005"
- Buttons: on/off, zero, mm/inch
- Automatic power off, move the digital unit to turn on power
- Meet DIN862
- Battery CR2032, data output
- Made of stainless steel
- Optional accessory: data output cable (code 7315-21 need receiver, 7302-21)

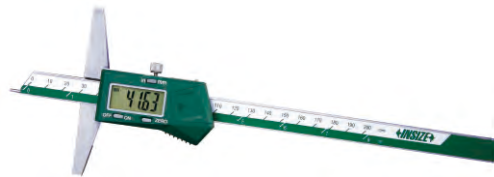

1143-200A

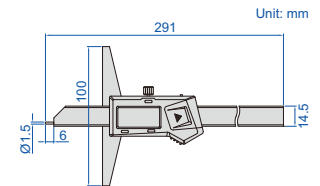

Code	Range	Accuracy
1143-200A	0-200mm/0-8"	±0.03mm

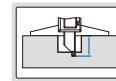

## DIGITAL DEPTH GAGES WITH ROUND DEPTH BAR

MEASURE DEPTH OF SMALL HOLES (>Ø4mm)      DATA OUTPUT      MEASURE WIDTH AND DEPTH OF GROOVES INSIDE BORE

preset buttons



extension base for 1148-200 (optional)



6141 series

- Non waterproof
- Resolution: 0.01mm/0.0005"
- Supplied with three interchangeable points (flat, spherical, disk)
- Buttons: on/off, set, mm/inch, preset (+, -)
- Automatic power off, move the digital unit to turn on power
- Battery CR2032, data output
- Made of stainless steel
- Optional accessory: data output cable (code 7315-21 need receiver, 7302-21), extension base (code 6141, for 1148-200)



1148-100S

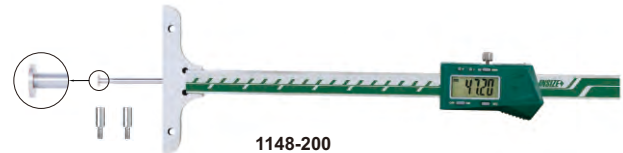

1148-200

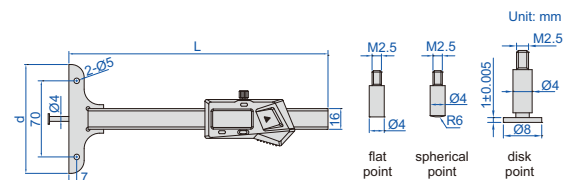

flat point      spherical point      disk point

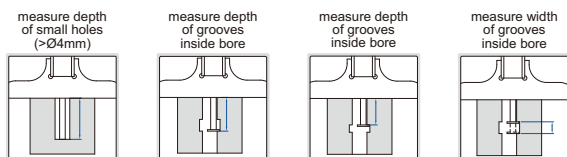

1148-P103 (optional), measure width of bottom grooves inside blind hole

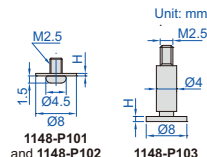
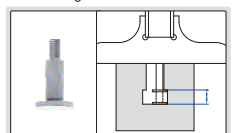

Code	Range*	Accuracy	L	d	Remark
1148-100S	0-100mm/0-4"	±0.02mm	200	45	
1148-100	0-100mm/0-4"	±0.02mm	200	85	
1148-200	0-200mm/0-8"	±0.03mm	300	101	with mounting holes for extension base

\*When disk points are used, the range is reduced by 10mm

### OPTIONAL DISK POINTS

Code	Description	H	Remark
1148-P101	0.5mm disk point	0.5±0.005mm	for narrow grooves
1148-P102	0.7mm disk point	0.7±0.005mm	for narrow grooves
1148-P103	1mm disk point	1±0.005mm	for grooves inside blind hole

### DIGITAL DOUBLE HOOK DEPTH GAGE

- Non waterproof
- Resolution: 0.01mm/0.0005"
- Buttons: on/off, zero, mm/inch, ABS/INC, data hold, TOL, set
- ABS/INC is for absolute and incremental measurement
- TOL is for tolerance measurement
- Made of stainless steel
- LR44 battery, data output
- Supplied with gage block for zero setting
- Optional accessory: extension base, wireless data transmission (transmitter code 7315-1150 need receiver), data output cable (code 7302-SPC7, keyboard format)

gage block for zero setting (included)



#### Extension base (optional)

Code	L
1540-L300	300mm
1540-L400	400mm
1540-L500	500mm
1540-L600	600mm
1540-L800	800mm

Code	Range	Accuracy
1540-300	0-300mm/0-12"	±0.04mm



1540-300

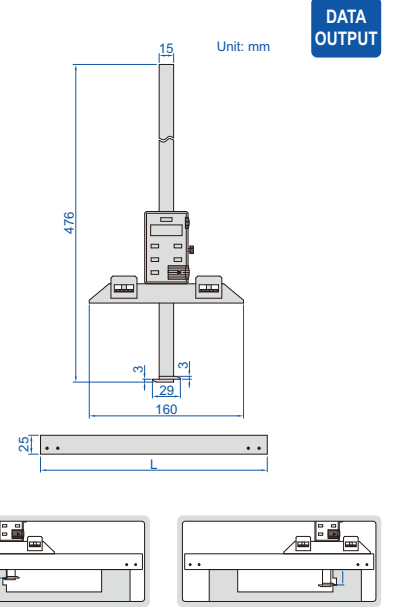

### DIAL DEPTH GAGES WITH ROUND BAR

SHOCK PROOF



1341-100

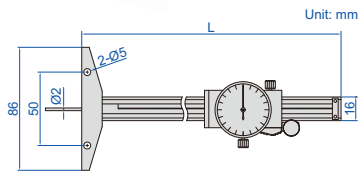

- Shockproof dial indicator
- Dial indicator graduation: 0.02mm
- Made of stainless steel

Code	Range	Accuracy	L
1341-100	0-100mm	±0.02mm	181mm
1341-200	0-200mm	±0.03mm	284mm

### DIAL DEPTH GAGES

SHOCK PROOF



1340-150

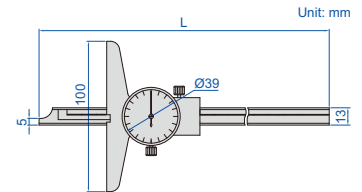

- Shockproof dial indicator
- Made of stainless steel

Code	Range	Graduation	Accuracy	L
1340-150	0-150mm	0.02mm	±0.03mm	232mm
1340-200	0-200mm	0.02mm	±0.03mm	282mm
1340-300	0-300mm	0.02mm	±0.04mm	382mm

### VERNIER DEPTH GAGES (STANDARD TYPE)

POPULAR MODEL

- Made of stainless steel
- Satin chrome plated reading surface



1240-2001

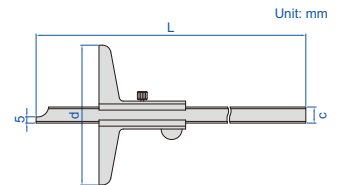

Graduation 0.05mm (mm)					
Code	Range	Accuracy	L	d	c
1240-150	0-150mm	±0.05mm	250	100	10
1240-200	0-200mm	±0.05mm	300	100	10
1240-300	0-300mm	±0.08mm	400	100	10
1240-500	0-500mm	±0.09mm	605	150	11

Graduation 0.02mm (mm)					
Code	Range	Accuracy	L	d	c
1240-1501	0-150mm	±0.03mm	250	100	10
1240-2001	0-200mm	±0.03mm	300	100	10
1240-3001	0-300mm	±0.04mm	400	100	10
1240-5001	0-500mm	±0.05mm	605	150	11

## EXTENSION BASES



6141-260

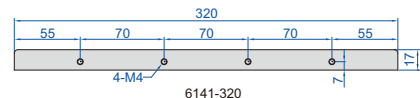
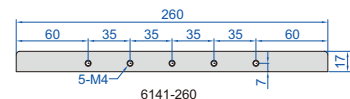
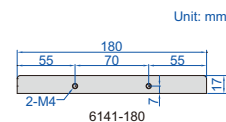

Code	Length
6141-180	180mm
6141-260	260mm
6141-320	320mm

- Supplied with two screws
- Made of stainless steel
- Suitable for depth gages series 1147, 1148, 1247, 1248 and 1249

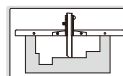
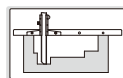

## MINI VERNIER DEPTH GAGE



1244-30

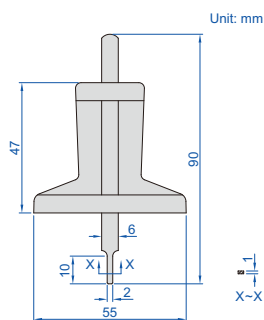

- Graduation: 0.1mm
- Made of stainless steel

Code	Range	Accuracy
1244-30	0-30mm	±0.10mm

## MINI DIGITAL DEPTH GAGES WITH ROUND BAR

DATA OUTPUT



1140-25

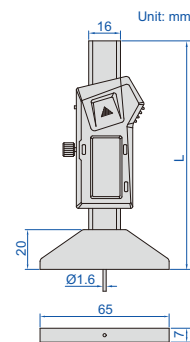

- Non waterproof
- Measure depth of small groove and hole
- Resolution: 0.01mm/0.0005"
- Buttons: on/off, set, mm/inch, preset (+,-)
- Automatic power off, move the digital unit to turn on power
- Battery CR2032
- Data output
- Made of stainless steel
- Optional accessory: data output cable (code 7315-21 need receiver, 7302-21)

Code	Range	Accuracy	L
1140-25	0-25mm/0-1"	±0.02mm	114mm
1140-50	0-50mm/0-2"	±0.02mm	140mm
1140-100	0-100mm/0-4"	±0.02mm	190mm
1140-150	0-150mm/0-6"	±0.03mm	236mm

## MINI DIGITAL DEPTH GAGE

DATA OUTPUT



1145-25A

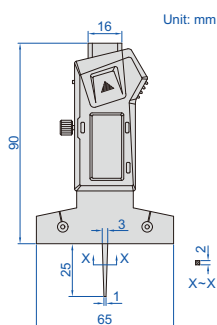

- Non waterproof
- Measure depth of small groove and hole, also measure depth of tire tread
- Resolution: 0.01mm/0.0005"
- Buttons: on/off, zero, mm/inch
- Supplied with zero set surface
- Automatic power off, move the digital unit to turn on power
- Battery CR2032, data output
- Made of stainless steel
- Optional accessory: data output cable (code 7315-21 need receiver, 7302-21)

Code	Range	Accuracy
1145-25A	0-25mm/0-1"	±0.03mm



## DIAL DEPTH GAGES

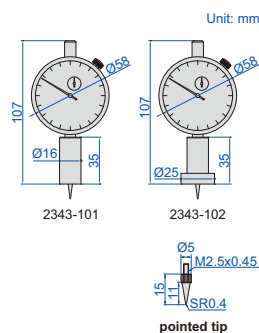

2343-102

- Accuracy: ±0.017mm
- Stainless steel base
- Pointed tip

Code	Range	Dial indicator stroke	Dial indicator graduation	Base
2343-101	0-10mm	10mm	0.01mm	Ø16mm
2343-102	0-10mm	10mm	0.01mm	Ø25mm

## DIGITAL DEPTH GAGES

**DATA OUTPUT**

- Accuracy:  $\pm 20\mu\text{m}$
- Button function: on/off, zero, mm/inch, ABS, data preset, change measuring direction
- CR2032 battery
- Automatic power off (time is adjustable)
- Data output
- Stainless steel base
- Extension rods: 12.5mm (1 pc), 25mm (1 pc), 50mm (1 pc), 75mm (1 pc), 100mm (2 pcs)
- Supplied with pointed tip and ball tip
- Optional accessory: data output cable (code **7315-50M** need receiver, **7302-40M**), granite extension holder (code **2141-10**)



2141-202A

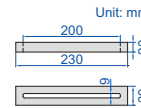
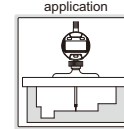
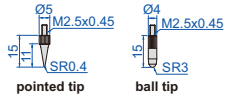
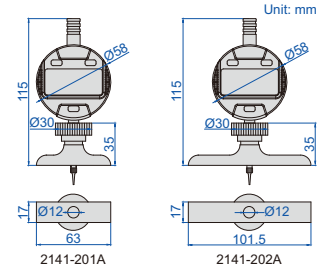

2141-10 (optional), can be customized according to workpieces

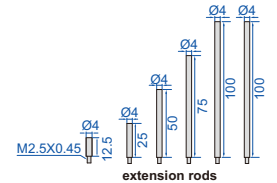

Code	Range	Digital indicator stroke	Digital indicator resolution	Base
2141-201A	0-300mm/0-12"	12.7mm/0.5"	0.01mm/0.0005"	63x17mm
2141-202A	0-300mm/0-12"	12.7mm/0.5"	0.01mm/0.0005"	101.5x17mm

## DIAL DEPTH GAGE



2342-202

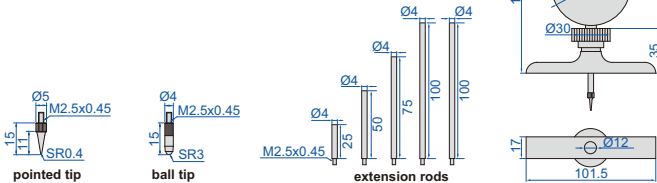

2141-10 (optional), can be customized according to workpieces

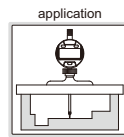
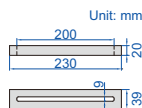

- Accuracy:  $\pm 0.03\text{mm}$
- Dial indicator stroke: 30mm
- Dial indicator graduation: 0.01mm
- Stainless steel base
- Extension rods: 25mm (1 pc), 50mm (1 pc), 75mm (1 pc), 100mm (2 pcs)
- Supplied with pointed tip and ball tip
- Optional accessory: granite extension holder (code **2141-10**)

Code	Range	Base
2342-202	0-300mm	101.5x17mm

## DIAL DEPTH GAGE

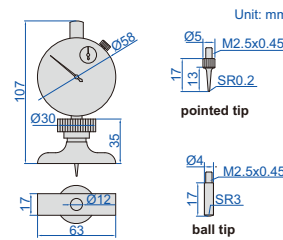

2341-101A

- Dial indicator graduation: 0.01mm
- Stainless steel base
- Supplied with pointed tip and ball tip

Code	Range	Dial indicator stroke	Accuracy
2341-101A	0-10mm	10mm	$\pm 0.017\text{mm}$

## DIGITAL DEPTH MICROMETERS

**DATA OUTPUT** **IP65 WATERPROOF**

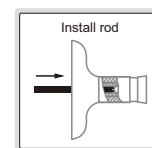

3540-50

- Resolution: 0.001mm/0.00005"
- Micrometer head accuracy:  $\pm 1-3\mu\text{m}$
- Rod accuracy:  $\pm (2+L/75)\mu\text{m}$ , L is the measuring range in mm
- Button function: on/off, set, mm/inch, data transmit
- IP65 dust/waterproof
- Automatic power off, data output
- Rods with flat end
- Ratchet stop
- Optional accessory: data output cable (code **7315-31** need receiver, **7302-31**)

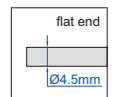

Code	Range	Rods
3540-50	0-50mm/0-2"	2 pcs
3540-150	0-150mm/0-6"	6 pcs
3540-300	0-300mm/0-12"	12 pcs

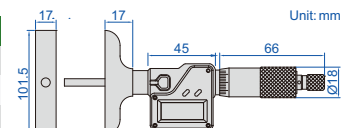

## DEPTH MICROMETERS



3240-25

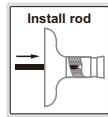

- Graduation: 0.01mm
- Meet DIN863-2
- Micrometer head accuracy:  $\pm 3\mu\text{m}$
- Rod accuracy:  $\pm(2+L/75)\mu\text{m}$ , L is the measuring range in mm
- Rods with flat end
- Ratchet stop

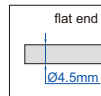
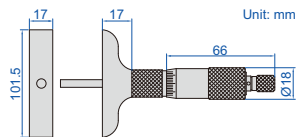

Code	Range	Rods
3240-25	0-25mm	1 pc
3240-50	0-50mm	2 pcs
3240-75	0-75mm	3 pcs
3240-100	0-100mm	4 pcs
3240-150	0-150mm	6 pcs
3240-200	0-200mm	8 pcs
3240-300	0-300mm	12 pcs

## DEPTH MICROMETERS



3241-150

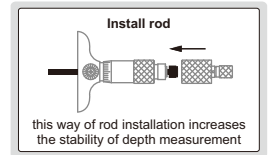

- Graduation: 0.01mm
- Meet DIN863-2
- Micrometer head accuracy:  $\pm 3\mu\text{m}$
- Rod accuracy:  $\pm(2+L/75)\mu\text{m}$ , L is the measuring range in mm
- Rods with flat end
- Ratchet stop

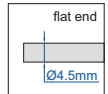
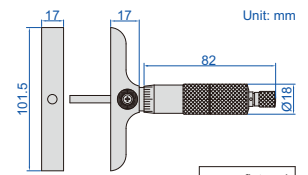

Code	Range	Rods
3241-25	0-25mm	1 pc
3241-50	0-50mm	2 pcs
3241-100	0-100mm	4 pcs
3241-150	0-150mm	6 pcs
3241-300	0-300mm	12 pcs

## HIGH PRECISION DIGITAL HEIGHT GAGES

DATA OUTPUT



power supplied by charge pal



data transmitted to Excel without software; short press the foot switch to transmit data, long press to zero

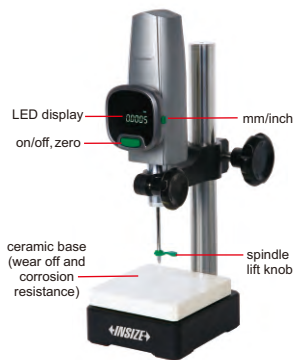

1155-505

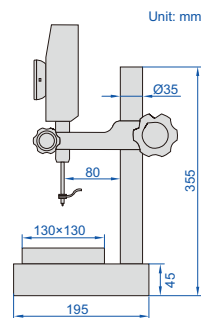

measuring tips (included)

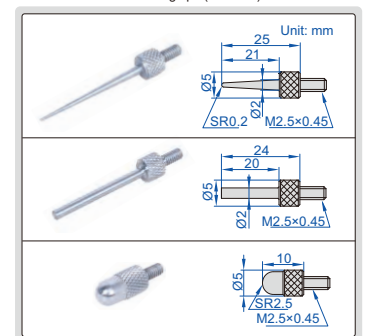

- Range: 0-50mm
- Measuring force: 0.8~1.2N
- Power supply: 5V/1A (adapter or charge pal)
- High stability, high precision, high response speed (5000mm/s)
- High brightness LED display
- Ceramic base flatness:  $1\mu\text{m}$

Code	Resolution	Accuracy (20°C)	Output
1155-505	0.5 $\mu\text{m}$ /0.00002" (can switch to: 1 $\mu\text{m}$ /0.00005")	1.5 $\mu\text{m}$	USB
1155-510	0.1 $\mu\text{m}$ /0.000005" (can switch to: 1 $\mu\text{m}$ /0.00005")	1 $\mu\text{m}$	USB

### STANDARD DELIVERY

Main unit	1 pc
-----------	------

### OPTIONAL ACCESSORY

Contact point	code 6282
Charge pal	1155-5-POB
Data output cable (including foot switch)	1155-5-FOS

## DIGITAL HEIGHT GAGES



1157-501

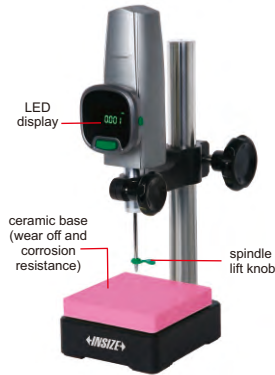
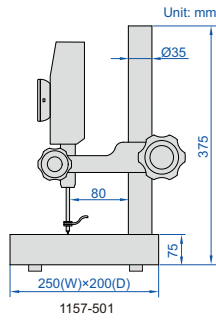

1157-502

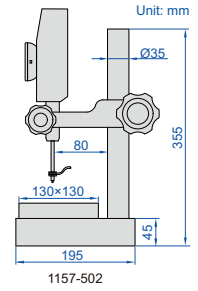

- Measuring force: 0.8~1.2N
- Power supply: 5V/1A (adapter or charge pal)
- Buttons: on/off, zero, mm/inch, mix/min/mix-min
- High response speed (5000mm/s)
- High brightness LED display

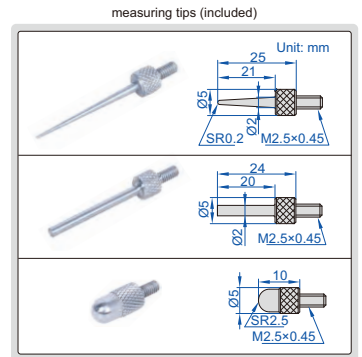
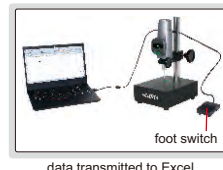

Code	Range	Resolution	Accuracy (20°C)	Output	Base
1157-501	0~50mm	1µm/0.00005"	3µm	USB	granite (flatness: 2µm)
1157-502	0~50mm	1µm/0.00005"	3µm	USB	ceramic (flatness: 1µm)

### OPTIONAL ACCESSORY

Contact point	code 6282
Charge pal	1155-5-POB
Data output cable (including foot switch)	1155-5-FOS

### STANDARD DELIVERY

Main unit	1 pc
-----------	------



## LARGE RANGE DIGITAL HEIGHT GAGE



- Measuring force: 0.8~1.2N
- Power supply: 5V/1A (adapter or charge pal)
- High stability, high precision, high response speed (5000mm/s)
- High brightness LED display
- Granite base flatness: 3µm

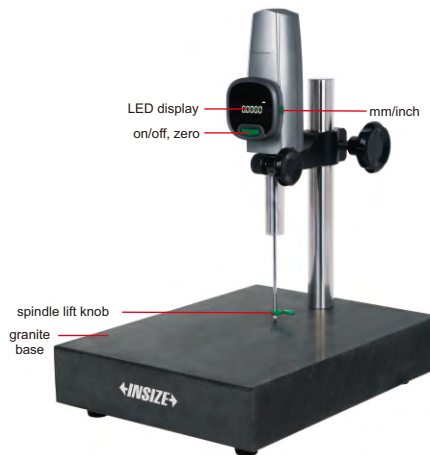

1158-100

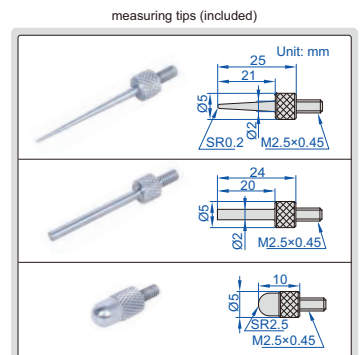
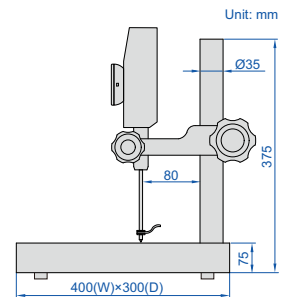

Code	Range	Resolution	Accuracy (20°C)	Output
1158-100	0~100mm	0.1µm/0.000005" (can switch to: 1µm/0.00005")	3µm	USB

### OPTIONAL ACCESSORY

Contact point	code 6282
Charge pal	1155-5-POB
Data output cable (including foot switch)	1155-5-FOS

### STANDARD DELIVERY

Main unit	1 pc
-----------	------



## DIGITAL HEIGHT GAGES

DATA OUTPUT

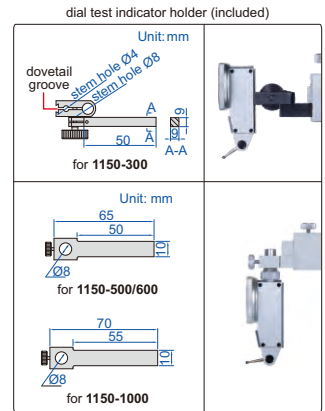
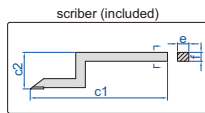
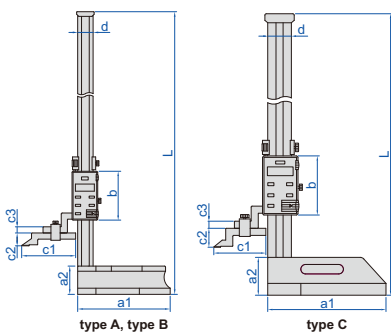

- Non waterproof
- Resolution: 0.01mm/0.0005"
- Buttons: on/off, zero, mm/inch, ABS/INC, data hold, TOL, set
- ABS/INC is for absolute and incremental measurement
- TOL is for tolerance measurement
- Carbide tipped scriber
- Made of stainless steel (except the base)
- LR44 battery, data output
- Supplied with dial test indicator holder
- Supplied with dust cover
- Optional accessory: data output cable (code **7302-SPC7**, keyboard format), wireless data transmission (transmitter code **7315-1150** need receiver), clamp for protractors (code **2372-CLAMP**, for **1150-300**)

(mm)

Code	Range	Type	Accuracy	L	a1	a2	b	c1	c2	c3	d	e	f
1150-300	0-300mm/0-12"	A	±0.04mm	485	138	45	95	80	30	10	28	9	9
1150-500	0-500mm/0-20"	B	±0.06mm	720	180	55	95	103	25	12	30	10	12
1150-600	0-600mm/0-24"	B	±0.06mm	820	180	55	95	103	25	12	30	10	12
1150-1000	0-1000mm/0-40"	C	±0.08mm	1275	250	80	125	110	39	15	50	10	15

clamp for protractors (optional) for 1150-300

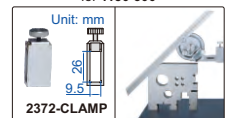

## DIGITAL HEIGHT GAGES WITH DRIVING WHEEL

POPULAR MODEL

INSPECTION CERTIFICATE

DATA OUTPUT

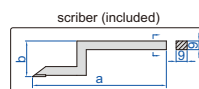
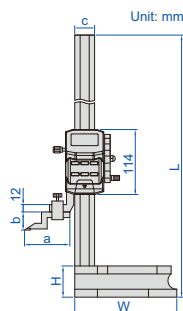
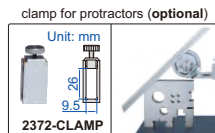
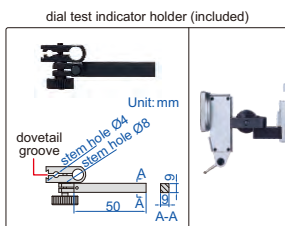

- Non waterproof
- Resolution: 0.01mm/0.0005"
- Buttons: on/off, zero, mm/inch, preset (+, -), hold
- Automatic power off, move the digital unit to turn on power
- Carbide tipped scriber
- Made of stainless steel
- Battery CR2032
- Data output
- Supplied with dust cover
- With dial test indicator holder
- Optional accessory: data output cable (code **7302-22**), wireless data transmission (transmitter code **7315-22** need receiver), clamp for protractors (code **2372-CLAMP**)

(mm)

Code	Range	Accuracy	L	W	H	a	b	c	h
1156-300*	0-300mm/0-12"	±0.03mm	515	180	55	80	30	35	9
1156-600*	0-600mm/0-24"	±0.05mm	815	180	55	80	30	35	9
1156-1000*	0-1000mm/0-40"	±0.07mm	1220	265	70	92	48	40	12

\*Supplied with manufacturer inspection certificate



## DIGITAL HEIGHT GAGES

- Non waterproof
- Resolution: 0.01mm/0.0005"
- Buttons: on/off, zero, mm/inch, data hold, ABS/INC, preset
- ABS/INC is for absolute and incremental measurement
- Automatic power off, move the digital unit to turn on power
- Carbide tipped scriber
- Made of stainless steel
- Battery CR2032, data output
- With driving wheel
- With dial test indicator holder
- Supplied with dust cover
- Optional accessory: clamp for protractors (code **2372-CLAMP**), wireless data transmission (transmitter code **7315-1151** need receiver), data output cable (code **7302-1151**, keyboard format)



1151-300A

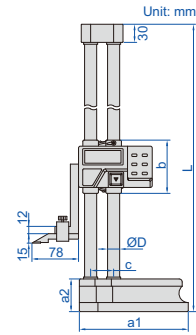

DATA OUTPUT

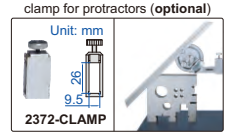
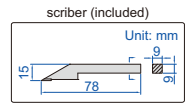

dial test indicator holder (included)

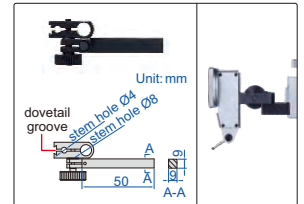

Code	Range	Accuracy	L	a1	a2	b	c	ØD
1151-300A	0-300mm/0-12"	±0.04mm	475	135	43	84	33	15
1151-450A	0-450mm/0-18"	±0.05mm	660	180	54	88	38	20
1151-600A	0-600mm/0-24"	±0.05mm	810	180	54	88	38	20

(mm)

## DIAL HEIGHT GAGES

- Dial indicator graduation: 0.01mm
- One counter reads in the plus direction and another in the minus direction, so incremental measurement can be made in either direction
- Carbide tipped scriber
- Made of stainless steel (except the base)
- With driving wheel
- With dial test indicator holder
- Supplied with dust cover
- Optional accessory: clamp for protractors (code **2372-CLAMP**)



1351-300

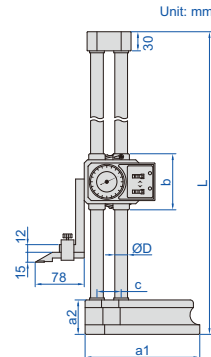

scraper (included)

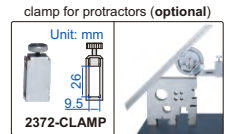
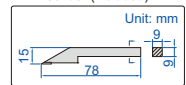

dial test indicator holder (included)

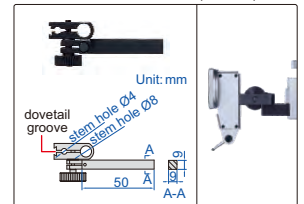

Code	Range	Accuracy	L	a1	a2	b	c	ØD
1351-300	0-300mm	±0.04mm	475	135	43	84	33	15
1351-450	0-450mm	±0.05mm	660	180	54	88	38	20
1351-600	0-600mm	±0.05mm	810	180	54	88	38	20

(mm)

## MINI DIGITAL HEIGHT GAGE

- Non waterproof
- Buttons: on/off, zero, mm/inch
- Automatic power off, move the digital unit to turn on power
- Carbide tipped scriber
- With fine adjustment
- Made of stainless steel
- Battery CR2032, data output
- Optional accessory: data output cable (code **7315-21** need receiver, **7302-21**), dial test indicator holder (code **7151-CL1**)



1154-150

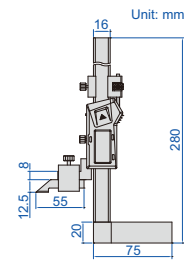

DATA OUTPUT

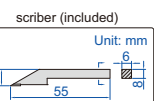

dial test indicator holder (optional)

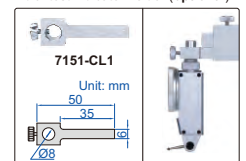

Code	Range	Accuracy	Resolution
1154-150	0-150mm/0-6"	±0.03mm	0.01mm/0.0005"

## VERNIER HEIGHT GAGES

- Graduation 0.02mm/0.001"
- Carbide tipped scriber
- Made of stainless steel (except the base)
- Satin chrome plated scale
- Optional accessory: dial test indicator holder (code **7151-CL1**)

dial test indicator holder (optional)

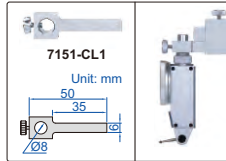

1253-200

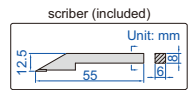
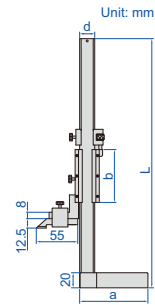

Code	Range	Accuracy	L	a	b	d
1253-150	0-150mm/0-6"	±0.03mm	265mm	75mm	57mm	16mm
1253-200	0-200mm/0-8"	±0.03mm	325mm	90mm	70mm	20mm

## VERNIER HEIGHT GAGES

- Graduation: 0.02mm/0.001"
- Adjustable main scale to set zero
- Carbide tipped scriber
- Made of stainless steel (except the base)
- Satin chrome plated scale
- Supplied with magnifier
- With fine adjustment
- Supplied with dust cover
- Optional accessory: dial test indicator holder (code **6293-6**), clamp for protractors (code **2372-CLAMP**)

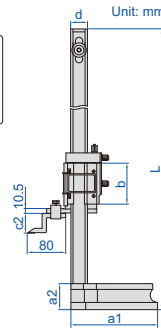
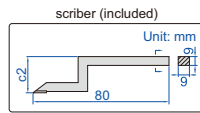

1250-300

clamp for protractors (optional)

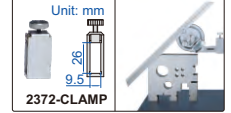

dial test indicator holder (optional)

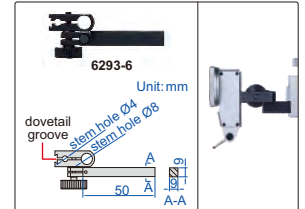

Code	Range	Accuracy	L	a1	a2	b	c2	d
1250-300	0-300mm/0-12"	±0.04mm	545mm	135mm	43mm	75mm	30mm	28mm
1250-600	0-600mm/0-24"	±0.05mm	870mm	180mm	54mm	85mm	41mm	35mm

## VERNIER HEIGHT GAGES (BASIC TYPE)

POPULAR MODEL

- Graduation: 0.02mm/0.001"
- Carbide tipped scriber
- Made of stainless steel (except the base)
- Satin chrome plated scale
- With dial test indicator holder
- Supplied with dust cover

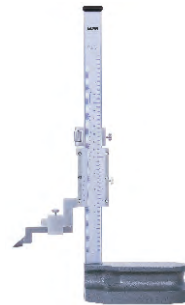
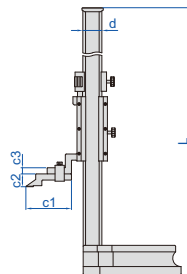
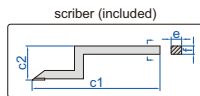

1251-200

dial test indicator holder (included)

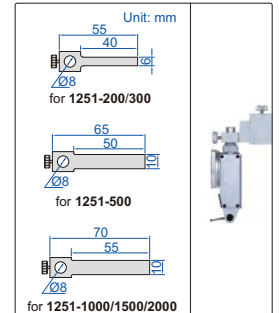

Code	Range	Accuracy	L	c1	c2	c3	d	e	f
1251-200	0-200mm/0-8"	±0.03mm	370	76	25	10	23	6	8
1251-300	0-300mm/0-12"	±0.04mm	470	76	25	10	23	6	8
1251-500	0-500mm/0-20"	±0.05mm	720	105	25	12	30	10	12
1251-1000	0-1000mm/0-40"	±0.07mm	1275	110	39	15	50	10	15
1251-1500	0-1500mm/0-60"	±0.11mm	1790	110	39	15	50	10	15
1251-2000	0-2000mm/0-80"	±0.14mm	2290	110	39	15	50	10	15

## CARBON FIBER COMPARISON GAGES

CARBON FIBER RODS, LIGHT WEIGHT, NOT EASY TO DEFORM, NO TEMPERATURE EXPAND, SUITABLE FOR THIN-WALL WORKPIECES AND LARGE-SIZE WORKPIECES

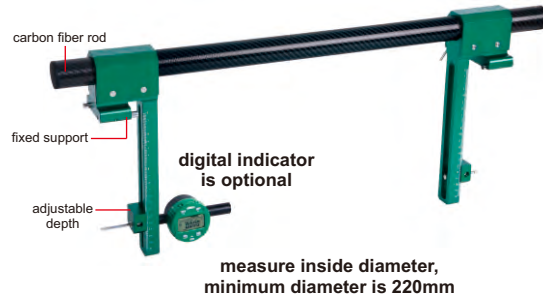
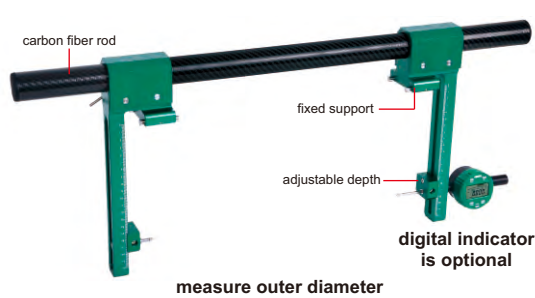

2931-D1000B

application

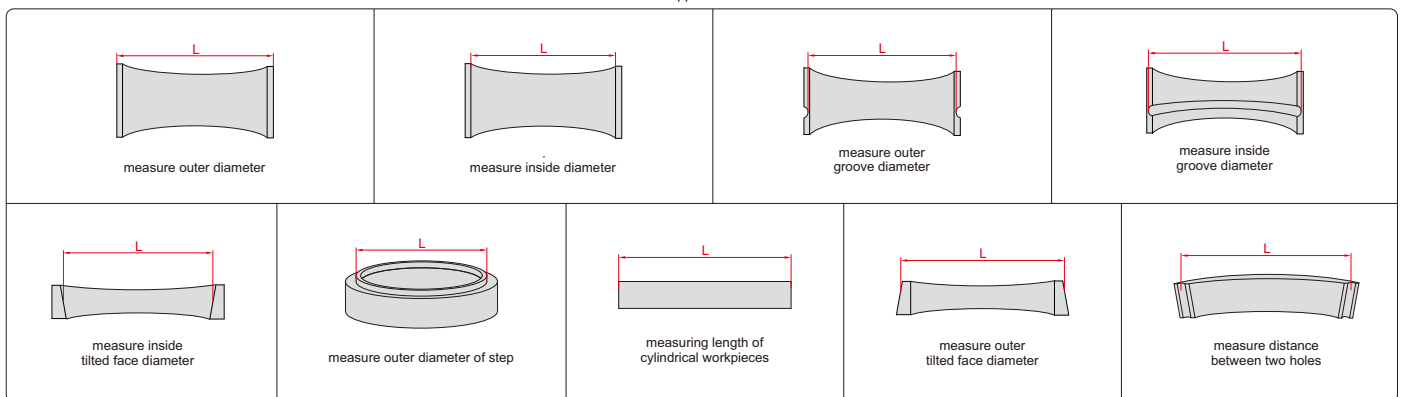

- Measure outer diameter, inside diameter, holes distance and cylindrical workpiece length
- Carbon fiber rods, light weight, not easy to deform, no temperature expand
- Optional accessory: cylinder gage blocks (code 4001), digital indicators (code 2138-25SP/2139-25SP/2103-25SP/2104-25SP)

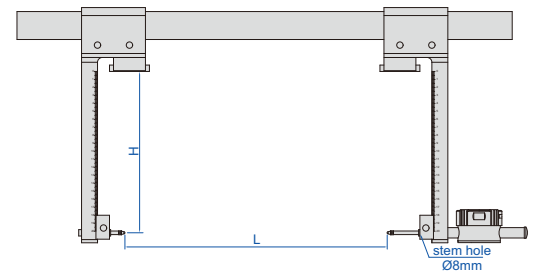

Code	Maximum measuring range (L)	Measuring depth (H)	Repeatability	Weight
2931-D1000A	1000mm	0-100mm	5µm	2.0kg
2931-D1000B	1000mm	0-200mm	10µm	2.3kg
2931-D1000C	1000mm	0-300mm	25µm	2.6kg
2931-D1500A	1500mm	0-100mm	8µm	2.3kg
2931-D1500B	1500mm	0-200mm	15µm	2.6kg
2931-D1500C	1500mm	0-300mm	30µm	2.9kg
2931-D2000A	2000mm	0-100mm	10µm	2.6kg
2931-D2000B	2000mm	0-200mm	20µm	2.9kg
2931-D2000C	2000mm	0-300mm	35µm	3.2kg
2931-D2500A	2500mm	0-100mm	12µm	2.9kg
2931-D2500B	2500mm	0-200mm	25µm	3.2kg
2931-D2500C	2500mm	0-300mm	50µm	3.5kg
2931-D3000A	3000mm	0-100mm	14µm	3.2kg
2931-D3000B	3000mm	0-200mm	30µm	3.5kg
2931-D3000C	3000mm	0-300mm	60µm	3.8kg
2931-D4000A	4000mm	0-100mm	16µm	3.8kg
2931-D4000B	4000mm	0-200mm	35µm	4.1kg
2931-D4000C	4000mm	0-300mm	65µm	4.4kg

# DIGITAL INTERNAL MEASURING GAGES

DATA OUTPUT



2932-45



2932-451

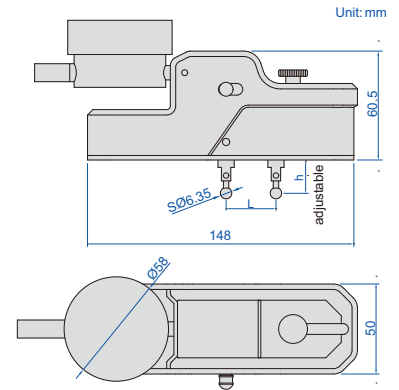

- Measure internal dimensions
- Resolution: 0.001mm/0.00005"
- Accuracy: 5µm
- Repeatability: 1µm
- Movable point stroke: 5mm/0.02"
- Point height is adjustable, h=2-25mm
- CR2032 battery, automatic power off (time is adjustable)
- Data output

Code	Measuring range (L) *	Indicator	Data output cable (optional)
2932-45	20-45mm/0.8-1.8"	button function: on/off, inch/mm, zero, data preset, change measuring direction, absolute/incremental measurement	7315-50M need receiver, 7302-40M
2932-451	20-45mm/0.8-1.8"	with transmission button and signal light; reading in digital and analog; display can be rotated by 320°; button function: on/off, inch/mm, zero, data preset, change measuring direction, absolute/incremental measurement, max./min./TIR measurement, tolerance Go and No-Go display	7315-51 need receiver, 7302-40M

\* The measuring range will change accordingly for different measuring points

## Disk points (optional, supplied in pair)

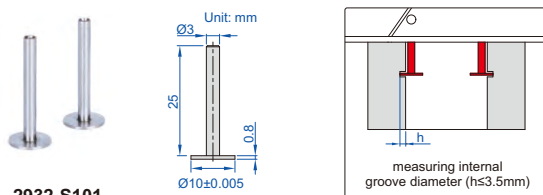

2932-S101

Code	Measuring range	Material
2932-S101	30-55mm/1.2-2.2"	stainless steel

## Conical points (optional, supplied in pair)

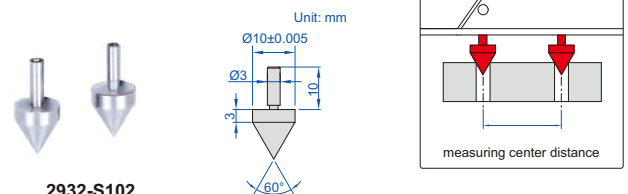

2932-S102

Code	Measuring range	Material
2932-S102	20-45mm/0.8-1.8"	stainless steel

## Spherical points (optional, supplied in pair)

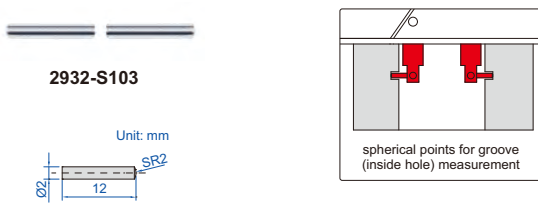

2932-S103

Code	Measuring range	Material
2932-S103	30-60mm/1.2-2.4"	stainless steel

## Spherical blade points (optional, supplied in pair)

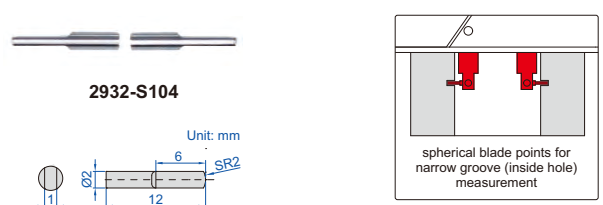

2932-S104

Code	Measuring range	Material
2932-S104	30-60mm/1.2-2.4"	stainless steel

To be continued

Continued from previous page

**Ball points (optional, supplied in pair)**



1527-T104

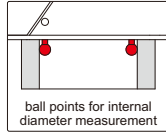
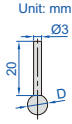

Code	Diameter (D)	Accuracy of diameter	Material
1527-T102	1/8" (Ø3.175mm)	±0.005mm	stainless steel
1527-T103	3/16" (Ø4.7625mm)	±0.005mm	stainless steel
1527-T104	1/4" (Ø6.35mm)	±0.005mm	stainless steel
1527-T105	3/8" (Ø9.525mm)	±0.005mm	stainless steel
1527-T106	1/2" (Ø12.7mm)	±0.005mm	stainless steel

**Point sleeve (optional, supplied in pair)**



1526-T101

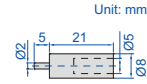

Code  
1526-T101

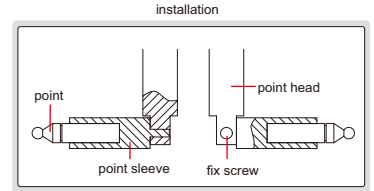

**Multifunctional points (optional, supplied in pair)**



7392-T1



7392-T4



7392-T7



7392-T2



7392-T5



7392-T8



7392-T3



7392-T6



7392-T9

Code	Type
7392-T1*	flat
7392-T2*	spherical
7392-T3*	spline

Code	Type
7392-T4*	disk
7392-T5*	blade
7392-T6*	knife-edge

Code	Type
7392-T7*	point
7392-T8*	knife-edge
7392-T9*	point

**Measuring range\*\***  
80-105mm/3.2-4.2"

\*\* After installing points and point sleeve

\* It is necessary to use point sleeve (code 1526-T101) for these points

**Screw thread points (optional, supplied in pair)**



7321-T16

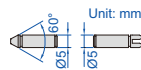

**Internal thread (60° thread angle)**

Code	Pitch
7321-T11*	0.4-0.5mm/64-48TPI
7321-T12*	0.6-0.9mm/44-28TPI
7321-T13*	1-1.75mm/24-14TPI
7321-T14*	2-3mm/13-9TPI
7321-T15*	3.5-5mm/8-5TPI
7321-T16*	5.5-7mm/4.5-3.5TPI
7321-T1S*	6 pairs/set, including all above points

**Measuring range\*\***  
80-105mm/3.2-4.2"

\*\* After installing points and point sleeve

\* It is necessary to use point sleeve (code 1526-T101) for these points

**Ball points (optional, supplied in pair)**



7391-T5

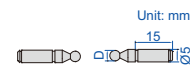

**Measuring range\*\***  
80-105mm/3.2-4.2"

\*\* After installing points and point sleeve

Code	Ball dia. (D)
7391-T3*	SØ2.0mm
7391-T4*	SØ2.5mm
7391-T5*	SØ3.0mm
7391-T6*	SØ3.5mm
7391-T7*	SØ4.0mm
7391-T8*	SØ4.5mm
7391-T9*	SØ5.0mm
7391-T10*	SØ6.0mm

\* It is necessary to use point sleeve (code 1526-T101) for these points

## HIGH PRECISION DIGITAL MICROMETER/SNAP GAGE

NON-ROTATING SPINDLE

ONE TURN OF SLEEVE MAKES 5MM SPINDLE FEED, PRESS THE FORK, THE SPINDLE RETRACTS 3MM

INSPECTION CERTIFICATE

DATA OUTPUT

IP65 WATERPROOF

MEASUREMENT ACCURACY IS NOT AFFECTED BY THE USE OF SLEEVE

ABSOLUTE ENCODER, THE ORIGINAL DATA REMAINS AFTER POWER OFF

ATTENTION: RECHARGEABLE BATTERY, FOR 24 HOURS CONTINUOUS WORKING

- Absolute encoder, the original data remains after power off
- Accuracy:  $\pm 0.5\mu\text{m}$ , repeatability:  $0.3\mu\text{m}$
- Resolution:  $0.0001\text{mm}/0.00001''$
- One turn of sleeve makes 10mm spindle feed
- Measurement accuracy is not affected by the use of sleeve
- Press the fork, the spindle retracts 3mm
- Carbide spindle and anvil
- Measuring force 5-10N
- Button function: data output, tolerance, data preset, data hold, measuring direction change, max./min./TIR, power off time, on/off, zero, mm/inch
- Power: rechargeable battery, for 24 hours continuous working



3359-25

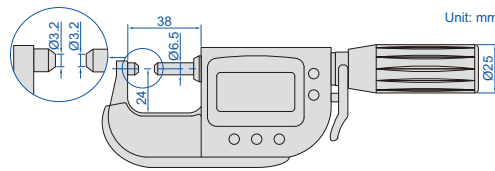

### With data interface

Optional accessory:  
wireless transmitter, code 7315-3350 need receiver  
data output cable (keyboard format), code 7302-3350

Code	Range	Measuring faces	
		flatness	parallelism
3359-25*	0-25mm/0-1"	$0.3\mu\text{m}$	$0.6\mu\text{m}$

\*Supplied with manufacturer inspection certificate

alarm when over tolerance

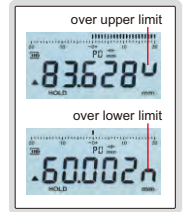

## DIGITAL MICROMETERS/SNAP GAGES

DATA OUTPUT

IP65 WATERPROOF

MEASUREMENT ACCURACY IS NOT AFFECTED BY THE USE OF SLEEVE

ATTENTION: RECHARGEABLE BATTERY, FOR 24 HOURS CONTINUOUS WORKING

POPULAR MODEL

INSPECTION CERTIFICATE

NON-ROTATING SPINDLE

ONE TURN OF SLEEVE MAKES 10MM SPINDLE FEED, PRESS THE FORK, THE SPINDLE RETRACTS 3MM

ABSOLUTE ENCODER, THE ORIGINAL DATA REMAINS AFTER POWER OFF

- Absolute encoder, the original data remains after power off
- Resolution:  $0.001\text{mm}/0.00005''$
- One turn of sleeve makes 10mm spindle feed
- Measurement accuracy is not affected by the use of sleeve
- Press the fork, the spindle retracts 3mm
- Carbide spindle and anvil
- Measuring force 5-10N
- Button function: data output, tolerance, data preset, data hold, measuring direction change, max./min./TIR, power off time, on/off, zero, mm/inch
- Supplied with gage blocks for zero setting (except 0-25mm/0-1")
- Power: rechargeable battery, for 24 hours continuous working



3358-25

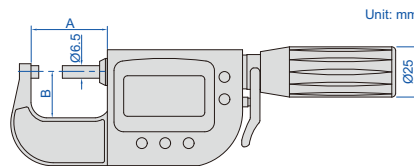

### With data interface

Optional accessory:  
wireless transmitter, code 7315-3350 need receiver  
data output cable (keyboard format), code 7302-3350

Code	Range	Accuracy	Repeatability	Measuring faces		A	B
				flatness	parallelism		
3358-25*	0-25mm/0-1"	$2\mu\text{m}$	$1\mu\text{m}$	$0.5\mu\text{m}$	$1.2\mu\text{m}$	38mm	24mm
3358-50*	25-50mm/1-2"	$2\mu\text{m}$	$1\mu\text{m}$	$0.5\mu\text{m}$	$1.2\mu\text{m}$	64mm	32.5mm
3358-75*	50-75mm/2-3"	$3\mu\text{m}$	$1\mu\text{m}$	$0.5\mu\text{m}$	$1.8\mu\text{m}$	89mm	46mm
3358-100*	75-100mm/3-4"	$3\mu\text{m}$	$1\mu\text{m}$	$0.5\mu\text{m}$	$1.8\mu\text{m}$	114mm	60mm

\*Supplied with manufacturer inspection certificate



alarm when over tolerance

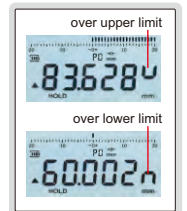

## DIGITAL MICROMETERS/SNAP GAGES (ADVANCED TYPE)



ABSOLUTE ENCODER, THE ORIGINAL DATA REMAINS AFTER POWER OFF

**IP65**  
WATERPROOF

- Absolute encoder, the original data remains after power off
- Adjustable resolution: 0.0002mm/0.00001"  
0.001mm/0.00005"  
0.01mm/0.0005"
- One turn of sleeve makes 5mm spindle feed
- Measurement accuracy is not affected by the use of sleeve
- Press the fork, the spindle retracts 3mm
- Linear ball bearings for ten million times use
- Carbide spindle and anvil
- Measuring force 7-10N  
Customizable measuring force range 2-12N  
Attention: small measuring force will reduce the dustproof and waterproof level
- Button function: data output, tolerance, data preset, data hold, measuring direction change, max./min./TIR, power off time, on/off, zero, mm/inch, adjust resolution
- Supplied with gage blocks for zero setting (except 0-25mm/0-1")
- Power: rechargeable battery, for 24 hours continuous working

MEASUREMENT ACCURACY IS NOT AFFECTED BY THE USE OF SLEEVE

ONE TURN OF SLEEVE MAKES 5MM SPINDLE FEED, PRESS THE FORK, THE SPINDLE RETRACTS 3MM

ATTENTION: RECHARGEABLE BATTERY, FOR 24 HOURS CONTINUOUS WORKING



3350-25

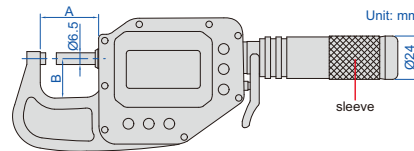

NON-ROTATING SPINDLE

DATA OUTPUT



### With data interface

Optional accessory:  
wireless transmitter, code 7315-3350 need receiver  
data output cable (keyboard format), code 7302-3350

Code	Range	Accuracy	Repeatability	Measuring faces		A	B
				Flatness	Parallelism		
3350-25*	0-25mm/0-1"	1.4µm	0.6µm	0.5µm	1µm	38mm	24mm
3350-50*	25-50mm/1-2"	1.6µm	1µm	0.5µm	1µm	63mm	28mm
3350-75*	50-75mm/2-3"	1.8µm	1µm	0.5µm	1µm	88mm	45mm
3350-100*	75-100mm/3-3.95"	2µm	1µm	0.5µm	1µm	113mm	57mm

\*Supplied with manufacturer inspection certificate

alarm when over tolerance

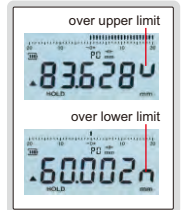

## WATERPROOF DIGITAL OUTSIDE MICROMETERS (WITH DATA OUTPUT)

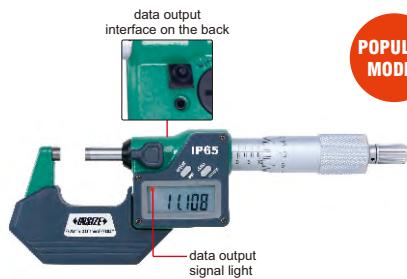

3101-25A

POPULAR MODEL



**IP65**  
WATERPROOF

DATA OUTPUT

- Resolution 0.001mm/0.00005"
- IP65 dust/waterproof
- Button function: on/off, set, mm/inch, data transmit
- Data output
- Automatic power off
- Carbide measuring faces
- Ratchet stop
- Supplied with spherical anvil
- Setting standards are included (except 0-25mm/0-1")
- Optional accessory: data output cable (code 7315-31 need receiver, 7302-31)

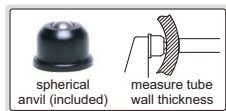
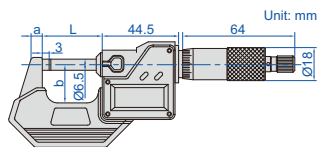

(mm)

Code	Range	Accuracy	L	a	b
3101-25A*	0-25mm/0-1"	±2µm	34.5	6	25
3101-50A*	25-50mm/1-2"	±2µm	59.5	8	32
3101-75A*	50-75mm/2-3"	±3µm	84.5	8	44.5
3101-100A*	75-100mm/3-4"	±3µm	109.5	8	57
3101-125A	100-125mm/4-5"	±3µm	135	10	70
3101-150A	125-150mm/5-6"	±3µm	160.5	10	82

\*Supplied with manufacturer inspection certificate

## WATERPROOF DIGITAL OUTSIDE MICROMETERS (WITHOUT DATA OUTPUT)



3108-25A



ATTENTION: NO DATA OUTPUT

**IP65**  
WATERPROOF

- Resolution 0.001mm/0.00005"
- IP65 dust/waterproof
- Button function: on/off, set, mm/inch, ABS/INC
- No data output
- Automatic power off
- Carbide measuring faces
- Ratchet stop
- Supplied with spherical anvil
- Setting standards are included (except 0-25mm/0-1")

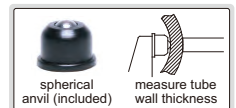
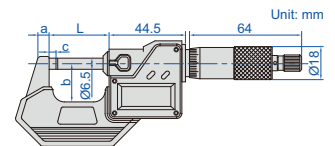

(mm)

Code	Range	Accuracy	L	a	b	c
3108-25A*	0-25mm/0-1"	±2µm	34.5	6	25	3
3108-50A*	25-50mm/1-2"	±2µm	59.5	8	32	3
3108-75A*	50-75mm/2-3"	±3µm	84.5	8	44.5	3
3108-100A*	75-100mm/3-4"	±3µm	109.5	8	57	3
3108-125A	100-125mm/4-5"	±3µm	135	10	70	3
3108-150A	125-150mm/5-6"	±3µm	160.5	10	82	3

\*Supplied with manufacturer inspection certificate



## DIGITAL OUTSIDE MICROMETERS (BASIC TYPE, WITHOUT DATA OUTPUT)

INSPECTION  
CERTIFICATE

ATTENTION: NO  
DATA OUTPUT

- Resolution 0.001mm/0.00005"
- Button function: on/off, set, mm/inch, ABS/INC
- No data output
- Automatic power off
- Carbide measuring faces
- Friction thimble
- Supplied with spherical anvil
- Setting standards are included (except 0-25mm/0-1")



3109-25A

POPULAR  
MODEL

Code	Range	Accuracy	L	a	b
3109-25A*	0-25mm/0-1"	±2μm	32	6	28
3109-50A*	25-50mm/1-2"	±2μm	57	8	37
3109-75A*	50-75mm/2-3"	±3μm	82	8	50
3109-100A*	75-100mm/3-4"	±3μm	107	10	61
3109-125A	100-125mm/4-5"	±3μm	132	10	73
3109-150A	125-150mm/5-6"	±3μm	157	10	85

(mm)

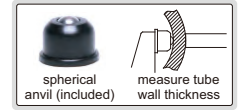
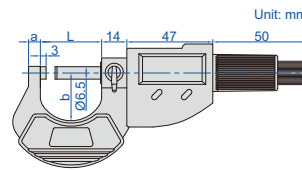

\*Supplied with manufacturer inspection certificate

## DIGITAL VERTICAL MICROMETER

INSPECTION  
CERTIFICATE

IP65  
WATERPROOF

DATA  
OUTPUT

- Measure the thickness of plates for easy reading
- Resolution 0.001mm/0.00005"
- IP65 dust/waterproof
- Button function: on/off, set, mm/inch, ABS/INC
- Data output
- Automatic power off
- Carbide spindle tip
- Ratchet stop
- Optional accessory: data output cable (code 7315-30 need receiver, 7302-30)



3565-25A

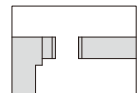
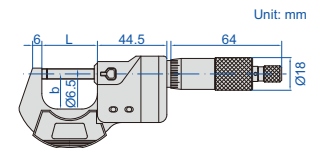

Code	Range	Accuracy	L	b
3565-25A*	0-25mm/0-1"	±2μm	34.5mm	25mm

\*Supplied with manufacturer inspection certificate

## OUTSIDE MICROMETERS

INSPECTION  
CERTIFICATE

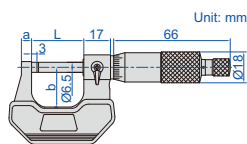

3202-25A

- Graduation 0.01mm
- Carbide measuring faces
- Meet DIN863-1
- Supplied with setting standards (except 0-25mm)

Individual			(mm)		
Code	Range	Accuracy	L	a	b
3202-25A*	0-25mm	4μm	32	6	24
3202-50A*	25-50mm	4μm	57	8	32
3202-75A*	50-75mm	5μm	82	8	45
3202-100A*	75-100mm	5μm	107	8	57

Set

Code	Range	Micrometers included
3202-1004A*	0-100mm	3202-25A, 3202-50A, 3202-75A, 3202-100A
3202-1506A	0-150mm	3202-25A, 3202-50A, 3202-75A, 3202-100A, 3202-125A, 3202-150A

\*Supplied with manufacturer inspection certificate

## OUTSIDE MICROMETER FOR LEFT OR RIGHT HANDERS

- Graduation 0.01mm
- Graduations on two sides
- Ratchet stop
- Carbide measuring faces
- Meet DIN863-1



front



back

3236-25B

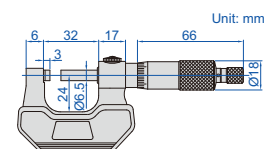

Code	Range	Accuracy
3236-25B	0-25mm	4μm

**OUTSIDE MICROMETERS**

**POPULAR MODEL**

**INSPECTION CERTIFICATE**

Individual (mm)

Code	Range	Accuracy	L	a	b
3203-25A*	0-25mm	±2µm	32	9	28
3203-50A*	25-50mm	±2µm	57	14	38
3203-75A*	50-75mm	±2µm	82	15	49
3203-100A*	75-100mm	±3µm	107	15	60
3203-125A	100-125mm	±3µm	133	16.5	73
3203-150A	125-150mm	±3µm	158	16.5	85
3203-175A	150-175mm	±4µm	183	19.4	104
3203-200A	175-200mm	±4µm	209	19.4	117
3203-225A	200-225mm	±4µm	234	19.4	130
3203-250A	225-250mm	±5µm	260	19.4	142
3203-275A	250-275mm	±5µm	285	19.4	155
3203-300A	275-300mm	±5µm	310	19.4	168



3203-25A



3203-50A

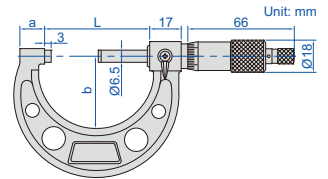

- Graduation: metric 0.01mm
- Carbide measuring faces
- Meet DIN863-1
- Ratchet stop
- Supplied with setting standards (except 0-25mm and 0-1")

Set

Code	Range	Micrometers included	Packaging
3203-1004A*	0-100mm	3203-25A, 3203-50A, 3203-75A, 3203-100A	blow mould case
3203-1506A	0-150mm	3203-25A, 3203-50A, 3203-75A, 3203-100A, 3203-125A, 3203-150A	blow mould case
3203-3006A	150-300mm	3203-175A, 3203-200A, 3203-225A, 3203-250A, 3203-275A, 3203-300A	aluminum box



3203-1004A



3203-3006A

\*Supplied with manufacturer inspection certificate

**1µm GRADUATION OUTSIDE MICROMETERS**

- Graduation: 0.001mm
- Carbide measuring faces
- Meet DIN863-1
- Ratchet stop
- Supplied with setting standards (except 0-25mm)

**INSPECTION CERTIFICATE**



3210-25A

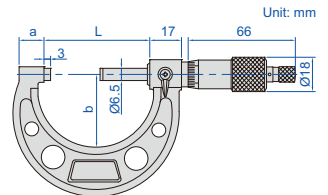

Individual (mm)

Code	Range	Accuracy	L	a	b
3210-25A*	0-25mm	4µm	32	9	28
3210-50A*	25-50mm	4µm	57	14	38
3210-75A*	50-75mm	5µm	82	15	49
3210-100A*	75-100mm	5µm	107	15	60

Set

Code	Range	Micrometers included
3210-1004A*	0-100mm	3210-25A, 3210-50A, 3210-75A, 3210-100A
3210-1506A	0-150mm	3210-25A, 3210-50A, 3210-75A, 3210-100A, 3210-125A, 3210-150A

\*Supplied with manufacturer inspection certificate

**OUTSIDE MICROMETERS WITH INTERCHANGEABLE ANVILS**

- Graduation 0.01mm
- Ratchet stop
- Meet DIN863-3
- Carbide measuring faces
- Supplied with setting standards

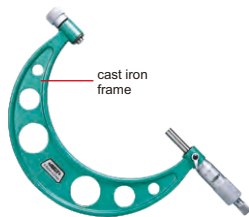

3206-150A

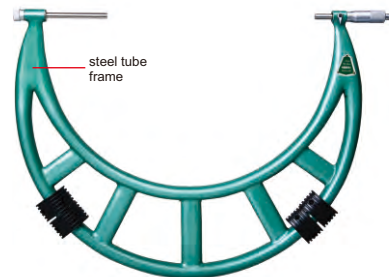

3206-400

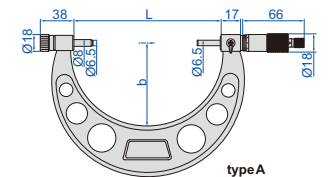

type A

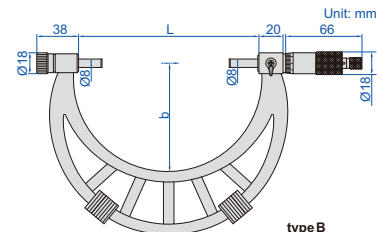

type B

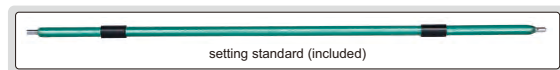

setting standard (included)

Code	Range	Type	Accuracy	L	b	Setting standard (included)
3206-150A	0-150mm	A	6µm	158	82	25, 50, 75, 100, 125
3206-200A	100-200mm	A	7µm	208	114	100, 125, 150, 175
3206-300A	150-300mm	A	9µm	308	165	150, 175, 200, 225, 250, 275
3206-301A	200-300mm	A	9µm	308	165	200, 225, 250, 275
3206-400	300-400mm	B	11µm	409	224	325, 375
3206-500	400-500mm	B	13µm	509	275	425, 475
3206-600	500-600mm	B	14µm	609	321	525, 575

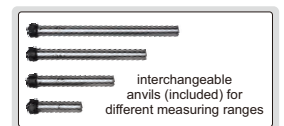

interchangeable anvils (included) for different measuring ranges

## DIGITAL OUTSIDE MICROMETERS WITH INTERCHANGEABLE ANVILS

**IP65**  
WATERPROOF

**DATA**  
OUTPUT



**3506-400A**

- Resolution 0.001mm/0.0001"
- IP65 dust/waterproof
- Button function: on/off, set, mm/inch, data transmit
- Data output
- Automatic power off
- Ratchet stop
- Carbide measuring faces
- Supplied with setting standards
- Optional accessory: data output cable (code 7315-31 need receiver, 7302-31)

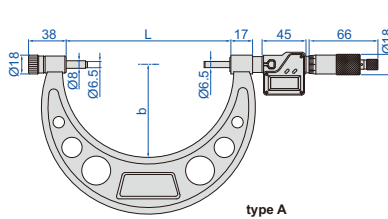

type A

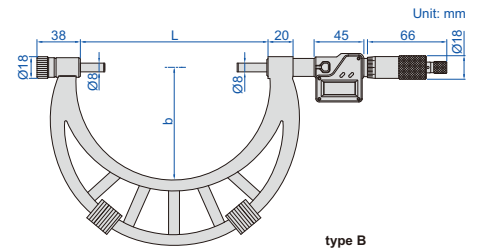

type B

Unit: mm

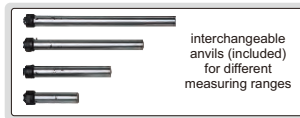

interchangeable anvils (included) for different measuring ranges

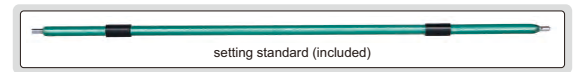

Code	Range	Type	Accuracy	L	b	Setting standard (included)
3506-300A	150-300mm/6-12"	A	±8µm	305	165	150, 175, 200, 225, 250, 275
3506-400A	300-400mm/12-16"	B	±9µm	405	224	325, 375
3506-500A	400-500mm/16-20"	B	±11µm	505	275	425, 475

(mm)

## INDICATING MICROMETERS

**ATTENTION: SETTING STANDARDS ARE NOT INCLUDED**

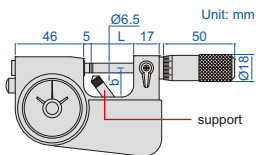

**3332-25**

- Meet DIN863-3
- Micrometer head graduation: 0.002mm
- Dial indicator: range ±0.04mm, graduation 0.001mm, accuracy 0.001mm
- Carbide measuring faces
- Optional accessory: gage blocks grade 0 (4101-A series), for zero setting

(mm)

Code	Micrometer head range	Micrometer head accuracy	L	b	Remark
3332-25	0-25mm	4µm	28.5	19	with support
3332-50	25-50mm	4µm	53.5	30	with support
3332-75	50-75mm	5µm	78.5	45	without support
3332-100	75-100mm	5µm	103.5	57	without support

## MICROMETER WITH DIAL INDICATOR

**ATTENTION: NOT SUITABLE FOR 0.001MM DIAL INDICATORS**



digital indicator is optional

**3331-25A**

- Meet DIN863-3
- Micrometer head graduation 0.01mm
- Anvil retracting range: 8mm
- Carbide measuring faces
- Optional accessory: dial indicators (graduation 0.01mm), digital indicators (resolution 0.01mm/0.0005")

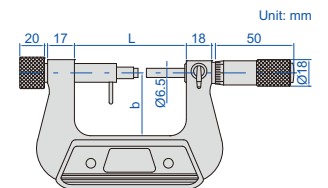

(mm)

Code	Micrometer head range	Micrometer head accuracy	L	b
3331-25A	0-25mm	4µm	67	38

## GROOVE MICROMETERS

- Measure width of grooves inside bores
- Graduation 0.01mm
- Two graduations for inside and outside measurements
- Non-rotating spindle
- Two-directional ratchet stop



**3287-25B**

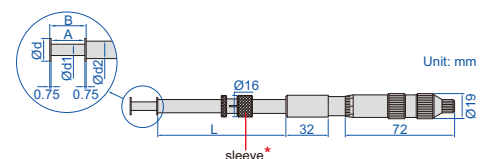

(mm)

Code	Range (outside A)	Range (inside B)	Accuracy	L	Ød	Ød1	Ød2
3287-25B	0-25mm	1.6-26.5mm	10µm	120	13	6.5	10
3287-251B*	0-25mm	1.6-26.5mm	10µm	90	6.5	3	5

\*3287-251B does not have sleeve

measure width of keyway

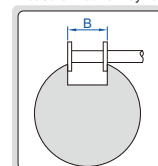

measure position of groove

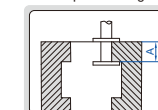

measure width of groove

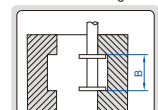

3-WIRES



7382-29

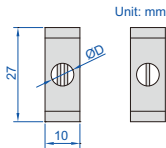

application



- Used with standard outside micrometers to measure pitch diameter of screw threads
- Diameter accuracy:  $\pm 0.5\mu\text{m}$
- Cylindricity:  $1\mu\text{m}$
- Hardness: HRC60
- Supplied with manufacturer inspection certificate

For outside micrometers with spindle  $\text{Ø}6.50\text{mm}$  ( $\text{ØD}$ )

Code	Pin gage diameter	Applicable pitch
7382-21	$\text{Ø}0.170\text{mm}$	0.2mm, 0.25mm, 0.3mm
7382-22	$\text{Ø}0.195\text{mm}$	0.35mm
7382-23	$\text{Ø}0.220\text{mm}$	0.4mm
7382-24	$\text{Ø}0.250\text{mm}$	0.45mm
7382-25	$\text{Ø}0.290\text{mm}$	0.5mm
7382-26	$\text{Ø}0.335\text{mm}$	0.6mm
7382-27	$\text{Ø}0.390\text{mm}$	0.7mm
7382-28	$\text{Ø}0.455\text{mm}$	0.75mm, 0.8mm
7382-29	$\text{Ø}0.530\text{mm}$	0.9mm
7382-210	$\text{Ø}0.620\text{mm}$	1.0mm
7382-211	$\text{Ø}0.725\text{mm}$	1.25mm
7382-212	$\text{Ø}0.895\text{mm}$	1.5mm
7382-213	$\text{Ø}1.100\text{mm}$	1.75mm, 2.0mm
7382-214	$\text{Ø}1.350\text{mm}$	2.5mm
7382-215	$\text{Ø}1.650\text{mm}$	3.0mm
7382-216	$\text{Ø}2.050\text{mm}$	3.5mm
7382-217	$\text{Ø}2.550\text{mm}$	4mm, 4.5mm
7382-218	$\text{Ø}3.200\text{mm}$	5mm, 5.5mm, 6mm
7382-2S	18 pairs/set, including all above 3-wires	

3-WIRES



CUSTOMIZABLE DIAMETER  $\text{Ød}$



7394-75A



- $\text{Ø}d \leq 0.3\text{mm}$ , made of alloy steel, hardness HRC60;
- $\text{Ø}d > 0.3\text{mm}$ , made of carbide, hardness HRA90
- Diameter accuracy:  $\pm 0.5\mu\text{m}$
- Cylindricity:  $\pm 0.5\mu\text{m}$
- Supplied with manufacturer inspection certificate

Code	Diameter ( $\text{Ø}d$ )	Applicable pitch
7394-60A *	0.170mm	0.2mm, 0.25mm, 0.3mm
7394-61A *	0.195mm	0.35mm
7394-62A *	0.220mm	0.4mm
7394-63A *	0.250mm	0.45mm
7394-64A *	0.290mm	0.5mm
7394-65A	0.335mm	0.6mm
7394-66A	0.390mm	0.7mm
7394-67A	0.455mm	0.75mm, 0.8mm
7394-68A	0.530mm	0.9mm
7394-69A	0.620mm	1.0mm
7394-70A	0.725mm	1.25mm
7394-71A	0.895mm	1.5mm
7394-72A	1.100mm	1.75mm, 2.0mm
7394-73A	1.350mm	2.5mm
7394-74A	1.650mm	3.0mm
7394-75A	2.050mm	3.5mm
7394-76A	2.550mm	4mm, 4.5mm
7394-77A	3.200mm	5mm, 5.5mm, 6mm

\* Made of alloy steel

SCREW THREAD MICROMETERS

accuracy of micrometers with tips (mm)

Pitch	Range					
	0-25	25-50	50-75	75-100	100-125	125-150
0.4~0.5	$\pm 0.01$	-	-	-	-	-
0.6~0.8	$\pm 0.01$	$\pm 0.013$	-	-	-	-
1~1.25	$\pm 0.012$	$\pm 0.015$	$\pm 0.017$	$\pm 0.017$	-	-
1.5~2.0	$\pm 0.014$	$\pm 0.017$	$\pm 0.019$	$\pm 0.019$	$\pm 0.020$	$\pm 0.023$
2.5~3.5	$\pm 0.016$	$\pm 0.019$	$\pm 0.021$	$\pm 0.021$	$\pm 0.023$	$\pm 0.025$
4.0~7.0	-	$\pm 0.021$	$\pm 0.023$	$\pm 0.023$	$\pm 0.025$	$\pm 0.028$

Code	Range	L	b	55° setting standard (optional)
3281-25A	0-25mm	42	26	-
3281-50A	25-50mm	67	38	3281-SP1
3281-75A	50-75mm	92	50	3281-SP2
3281-100A	75-100mm	117.6	62	3281-SP3
3281-125A	100-125mm	143	70	3281-SP4
3281-150A	125-150mm	168.2	82	3281-SP5



3281-25A (measuring tips are optional)

NON-ROTATING SPINDLE

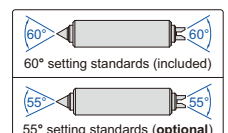
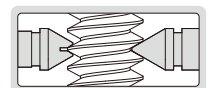
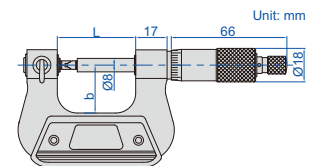

- Measure pitch diameter of screw threads
- Graduation 0.01mm
- Non-rotating spindle
- Ratchet stop
- Supplied with 60° setting standards (except 0-25mm)
- Optional accessory: 55° setting standards, measuring tips (code 7381)

## DIGITAL SCREW THREAD MICROMETERS

NON-ROTATING SPINDLE

DATA OUTPUT

- Measure pitch diameter of screw threads
- Resolution 0.001mm/0.00005"
- Button function: on/off, set, mm/inch, data transmit
- Data output
- Automatic power off
- Non-rotating spindle
- Ratchet stop
- Supplied with 60° setting standards (except 0-25mm/0-1")
- Optional accessory: 55° setting standards, measuring tips (code 7381), data output cable (code 7315-31 need receiver, 7302-31)



**3581-25A**  
(measuring tips are optional)

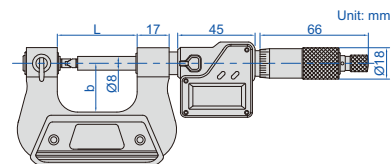

accuracy of micrometers with tips (mm)

Pitch	Range			
	0-25	25-50	50-75	75-100
0.4-0.5	±0.01	-	-	-
0.6-0.8	±0.01	±0.013	-	-
1-1.25	±0.012	±0.015	±0.017	±0.017
1.5-2.0	±0.014	±0.017	±0.019	±0.019
2.5-3.5	±0.016	±0.019	±0.021	±0.021
4.0-7.0	-	±0.021	±0.023	±0.023

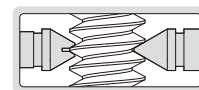

Code	Range	L	b	55° setting standard (optional)
3581-25A	0-25mm/0-1"	42	26	-
3581-50A	25-50mm/1-2"	67	38	3281-SP1
3581-75A	50-75mm/2-3"	92	50	3281-SP2
3581-100A	75-100mm/3-4"	117.6	62	3281-SP3

## MEASURING TIPS FOR SCREW THREAD MICROMETERS



7381-T13

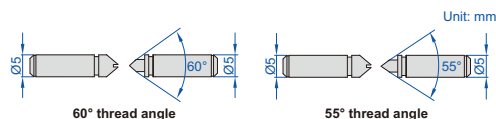

- Supplied in pairs
- Suitable for 3281, 3581 series micrometers

Whitworth thread (55° thread angle)

Code	Pitch
7381-T2S	10 pairs/set: 60-48TPI, 48-40TPI, 40-32TPI, 32-24TPI, 24-18TPI, 18-14TPI, 14-10TPI, 10-7TPI, 7-4.5TPI, 4.5-3.5TPI, including all above tips

Metric and unified thread (60° thread angle)

Code	Pitch
7381-T11	0.4-0.5mm/64-48TPI
7381-T12	0.6-0.9mm/44-28TPI
7381-T13	1-1.75mm/24-14TPI
7381-T14	2-3mm/13-9TPI
7381-T15	3.5-5mm/8-5TPI
7381-T16	5.5-7mm/4.5-3.5TPI
7381-TS	6 pairs/set, including all above tips

## GEAR TOOTH MICROMETERS



3291-25

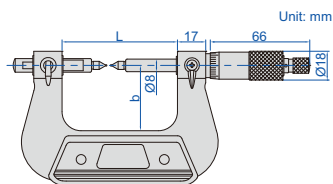

- Meet DIN863-3
- Measure over-pin diameter of gears
- Graduation 0.01mm
- Ratchet stop
- Supplied with setting standards (except 0-25mm)
- Optional accessory: ball tips (code 7391)

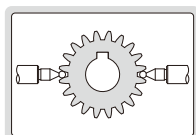

Code	Range	Accuracy	L	b
3291-25	0-25mm	4µm	67	38
3291-50	25-50mm	4µm	92.4	50
3291-75	50-75mm	5µm	117.6	62
3291-100	75-100mm	5µm	143	70

## DIGITAL GEAR TOOTH MICROMETERS

IP65 WATERPROOF

DATA OUTPUT



3591-25A

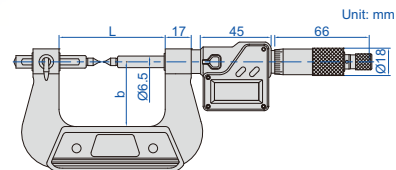

- Measure over-pin diameter of gears
- Resolution 0.001mm/0.00005"
- IP65 dust/waterproof
- Button function: on/off, set, mm/inch, data transmit
- Data output
- Automatic power off
- Ratchet stop
- Supplied with setting standards (except 0-25mm/0-1")
- Optional accessory: ball tips (code 7391), data output cable (code 7315-31 need receiver, 7302-31)

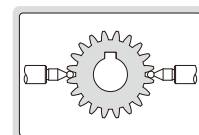

Code	Range	Accuracy	L	b
3591-25A	0-25mm/0-1"	±4µm	67	38
3591-50A	25-50mm/1-2"	±4µm	92.4	50
3591-75A	50-75mm/2-3"	±5µm	117.6	62
3591-100A	75-100mm/3-4"	±5µm	143	70

## BALL TIPS FOR GEAR TOOTH MICROMETERS

BALL TIPS DIAMETER SØD CAN BE CUSTOMIZED WITH SIZES BETWEEN 1.50-6.00MM



7391-T5

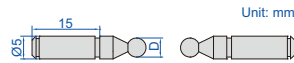

- Supplied in pair
- Suitable for 3291, 3591 series micrometers

Code	Ball dia. (D)
7391-T2	SØ1.5mm
7391-T3	SØ2.0mm
7391-T4	SØ2.5mm
7391-T5	SØ3.0mm
7391-T6	SØ3.5mm

Code	Ball dia. (D)
7391-T7	SØ4.0mm
7391-T8	SØ4.5mm
7391-T9	SØ5.0mm
7391-T10	SØ6.0mm

## POINT MICROMETERS



3230-25A

- Graduation 0.01mm
- Measure the web thickness of drills, small grooves and keyways
- Ratchet stop
- Carbide tips
- Supplied with setting standards (except 0-25mm)

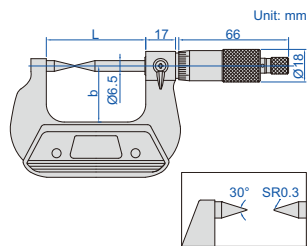

Code	Range	Accuracy	L	b
3230-25A	0-25mm	4µm	57mm	32mm
3230-50A	25-50mm	4µm	82mm	44.5mm
3230-75A	50-75mm	5µm	107mm	57mm
3230-100A	75-100mm	5µm	132.6mm	69.5mm

## DIGITAL POINT MICROMETERS

IP65 WATERPROOF

DATA OUTPUT



3530-25A

- Measure the web thickness of drills, small grooves and keyways
- Resolution 0.001mm/0.00005"
- IP65 dust/waterproof
- Button function: on/off, set, mm/inch, data transmit
- Data output
- Automatic power off
- Ratchet stop
- Carbide tips
- Supplied with setting standards (except 0-25mm/0-1")
- Optional accessory: data output cable (code 7315-31 need receiver, 7302-31)

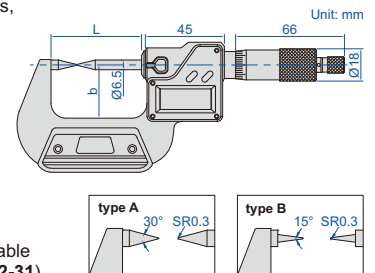

Code	Range	Type	Accuracy	L	b
3530-25A	0-25mm/0-1"	A	±4µm	57mm	32mm
3530-50A	25-50mm/1-2"	A	±4µm	82mm	44.5mm
3530-25BA	0-25mm/0-1"	B	±4µm	57mm	32mm
3530-50BA	25-50mm/1-2"	B	±4µm	82mm	44.5mm

## BLADE MICROMETERS

NON-ROTATING SPINDLE



3232-25A

- Meet DIN863-3
- Measure the groove diameter of shafts and keyways
- Graduation: 0.01mm
- Non-rotating spindle
- Ratchet stop
- Supplied with setting standards (except 0-25mm)

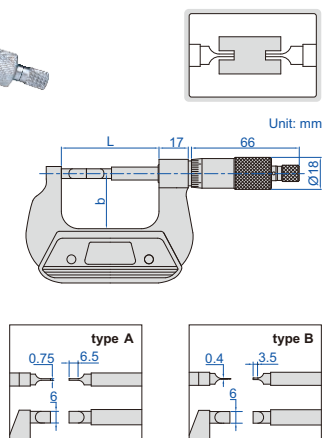

Code	Range	Type	Accuracy	L	b
3232-25A	0-25mm	A	4µm	57mm	32mm
3232-50A	25-50mm	A	4µm	82mm	44.5mm
3232-75A	50-75mm	A	5µm	107mm	57mm
3232-100A	75-100mm	A	5µm	132.6mm	69.5mm
3232-25BA	0-25mm	B	4µm	57mm	32mm

## DIGITAL BLADE MICROMETERS

NON-ROTATING SPINDLE

DATA OUTPUT



3532-25A

- Measure the groove diameter of shafts and keyways
- Resolution 0.001mm/0.00005"
- Non-rotating spindle
- Button function: on/off, set, mm/inch, data transmit
- Data output, automatic power off
- Ratchet stop
- Supplied with setting standards (except 0-25mm/0-1")
- Optional accessory: data output cable (code 7315-31 need receiver, 7302-31)

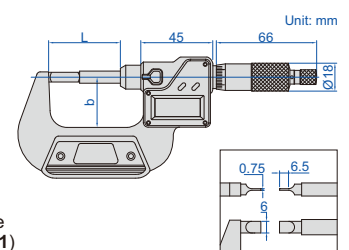

Code	Range	Accuracy	L	b
3532-25A	0-25mm/0-1"	±4µm	57	32
3532-50A	25-50mm/1-2"	±4µm	82	44.5

### CRIMP HEIGHT MICROMETER



3266-25BA

- Measure the height of crimp contact
- Graduation 0.01mm
- Ratchet stop

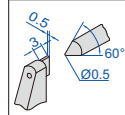
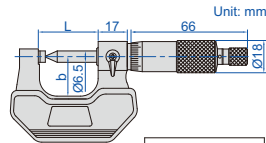

Code	Range	Accuracy	L	b
3266-25BA	0-25mm	4µm	34mm	24mm

### DIGITAL CRIMP HEIGHT MICROMETER

**IP65**  
WATERPROOF

**DATA**  
**OUTPUT**



3566-25BA

- Measure the height of crimp contact
- Resolution 0.001mm/0.00005"
- IP65 dust/waterproof
- Button function: on/off, set, mm/inch, data transmit
- Data output, automatic power off
- Ratchet stop
- Optional accessory: data output cable (code 7315-31 need receiver, 7302-31)

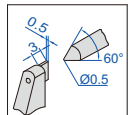
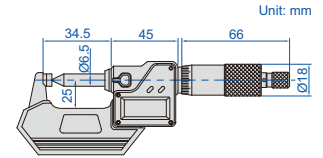

Code	Range	Accuracy
3566-25BA	0-25mm/0-1"	±4µm

### SPLINE MICROMETER



3233-25A

- Meet DIN863-3
- Measure splined shafts, slots and keyways
- Graduation 0.01mm
- Ratchet stop
- Carbide measuring faces

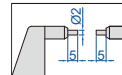
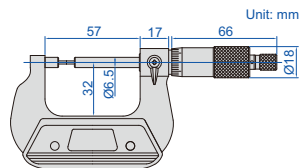

Code	Range	Accuracy
3233-25A	0-25mm	4µm

### CYLINDRICAL ANVIL TUBE MICROMETER



3261-25A

- Measure wall thickness of tubes
- Graduation 0.01mm
- Ratchet stop
- Carbide spindle tip

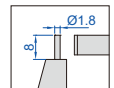
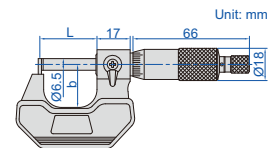

Code	Range	Accuracy	L	b
3261-25A	0-25mm	6µm	36mm	25mm

### DIGITAL SPLINE MICROMETER

**DATA**  
**OUTPUT**

**IP65**  
WATERPROOF



3533-25A

- Measure splined shafts, slots and keyways
- IP65 dust/waterproof
- Button function: on/off, set, mm/inch, data transmit
- Data output
- Automatic power off
- Ratchet stop
- Carbide measuring faces
- Optional accessory: data output cable (code 7315-31 need receiver, 7302-31)

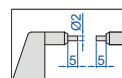
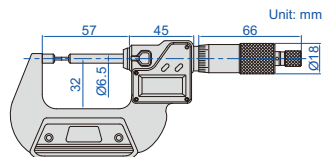

Code	Range	Accuracy	Resolution
3533-25A	0-25mm/0-1"	±4µm	0.001mm/0.00005"

### DIGITAL CYLINDRICAL ANVIL TUBE MICROMETER

**IP65**  
WATERPROOF

**DATA**  
**OUTPUT**



3561-25A

- Measure wall thickness of tubes
- Resolution 0.001mm/0.00005"
- IP65 dust/waterproof
- Button function: on/off, set, mm/inch, data transmit
- Data output, automatic power off
- Ratchet stop
- Carbide spindle tip
- Optional accessory: data output cable (code 7315-31 need receiver, 7302-31)

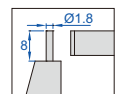
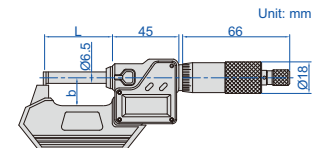

Code	Range	Accuracy	L	b
3561-25A	0-25mm/0-1"	±6µm	36mm	25mm

**SPHERICAL ANVIL TUBE MICROMETERS**



**3260-25A**

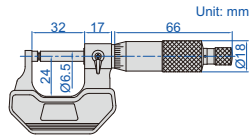
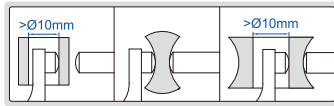

- Meet DIN863-3
- Measure wall thickness of tubes
- Graduation: 0.01mm
- Ratchet stop
- Carbide measuring faces

Code	Range	Type	Accuracy
3260-25A	0-25mm	A	4µm
3260-25SA	0-25mm	B	4µm

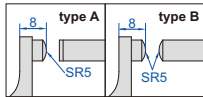

**DIGITAL SPHERICAL ANVIL TUBE MICROMETERS**



**3560-25A**

**IP65**  
WATERPROOF

**DATA**  
OUTPUT

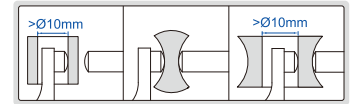

- Measure wall thickness of tubes
- Resolution 0.001mm/0.00005"
- IP65 dust/waterproof
- Button function: on/off, set, mm/inch, data transmit
- Data output, automatic power off
- Ratchet stop
- Carbide measuring faces
- Optional accessory: data output cable (code 7315-31 need receiver, 7302-31)

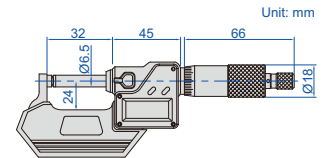

Code	Range	Type	Accuracy
3560-25A	0-25mm/0-1"	A	±4µm
3560-25SA	0-25mm/0-1"	B	±4µm

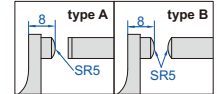

**SHEET METAL MICROMETER**

- Deep frame suitable for sheet metal, paper and plastic
- Graduation 0.01mm
- Ratchet stop
- Carbide measuring faces

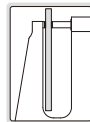

**3239-253**

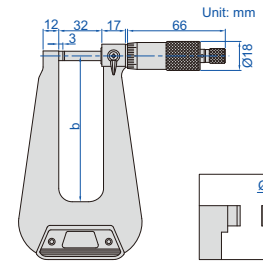

Code	Range	Accuracy	b
3239-253	0-25mm	7µm	155mm

**DIGITAL SHEET METAL MICROMETER**



**3539-253A**

**IP65**  
WATERPROOF

**DATA**  
OUTPUT

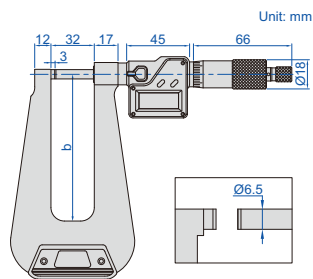

- Deep frame suitable for sheet metal, paper and plastic
- Resolution 0.001mm/0.00005"
- IP65 dust/waterproof
- Button function: on/off, set, mm/inch, data transmit
- Automatic power off, data output
- Ratchet stop
- Carbide measuring faces
- Optional accessory: data output cable (code 7315-31 need receiver, 7302-31)

Code	Range	Accuracy	b
3539-253A	0-25mm/0-1"	±7µm	155mm

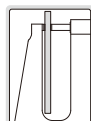

**INTERCHANGEABLE ANVIL MICROMETERS**



**3262-25A**

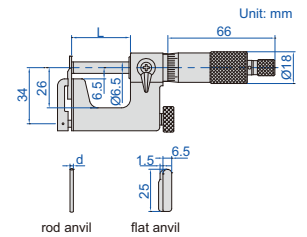

- Measure tube thickness, shoulder edge distance, rivet head height, etc.
- Supplied with flat anvil and rod anvil
- Graduation 0.01mm
- Ratchet stop
- Carbide spindle tip
- Setting standards are included (except 0-25mm)

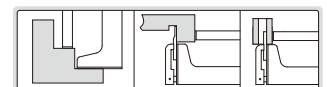

Code	Range	Accuracy	L	d
3262-25A	0-25mm	4µm	28.5mm	Ø3mm
3262-50A	25-50mm	4µm	53.5mm	Ø5mm



## DIGITAL INTERCHANGEABLE ANVIL MICROMETERS

**IP65**  
WATERPROOF

**DATA**  
OUTPUT

- Measure tube thickness, shoulder edge distance, rivet head height, etc.
- Supplied with flat anvil and rod anvil
- Resolution 0.001mm/0.00005"
- IP65 dust/waterproof
- Button function: on/off, set, mm/inch, data transmit
- Data output, automatic power off
- Ratchet stop
- Carbide spindle tip
- Setting standards are included (except 0-25mm/0-1")
- Optional accessory: data output cable (code 7315-31 need receiver, 7302-31)



3562-25A

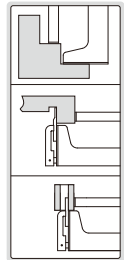
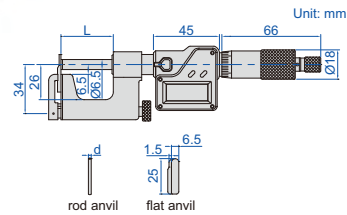

Code	Range	Accuracy	L	d
3562-25A	0-25mm/0-1"	±4μm	28.5mm	Ø3mm
3562-50A	25-50mm/1-2"	±4μm	53.5mm	Ø5mm

## LARGE ANVIL MICROMETER



3234-25A

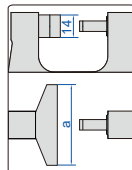
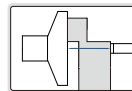
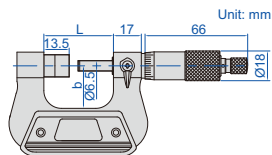

- Graduation 0.01mm
- Ratchet stop

Code	Range	Accuracy	L	a	b
3234-25A	0-25mm	4μm	42mm	50mm	26mm

## V-ANVIL MICROMETER



3290-153A

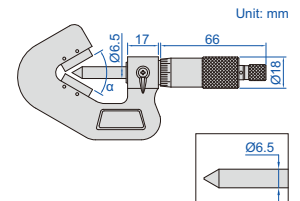

- Measure the diameter of parts or cutting tools with odd grooves, such as taps, reamers and end mills
- Graduation 0.01mm
- Ratchet stop
- Carbide measuring faces
- Supplied with setting standards

Code	Range	Flutes	Accuracy	α
3290-153A	1-15mm	3	4μm	60°

## DIGITAL LARGE ANVIL MICROMETER

**IP65**  
WATERPROOF

**DATA**  
OUTPUT



3534-25A

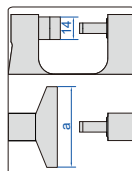
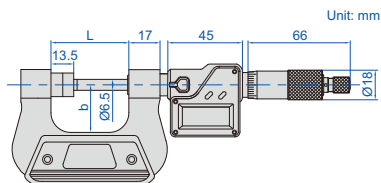
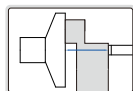

- Resolution 0.001mm/0.00005"
- IP65 dust/waterproof
- Button function: on/off, set, mm/inch, data transmit
- Data output
- Automatic power off
- Ratchet stop
- Optional accessory: data output cable (code 7315-31 need receiver, 7302-31)

Code	Range	Accuracy	L	a	b
3534-25A	0-25mm/0-1"	±4μm	42	50	26

## DIGITAL V-ANVIL MICROMETER

**IP65**  
WATERPROOF

**DATA**  
OUTPUT



3590-153A

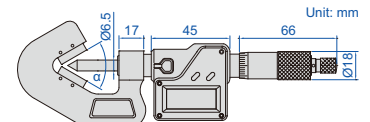
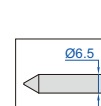

- Measure the diameter of parts or cutting tools with odd grooves, such as taps, reamers and end mills
- Resolution 0.001mm/0.00005"
- IP65 dust/waterproof
- Button function: on/off, set, mm/inch, data transmit
- Data output, automatic power off
- Ratchet stop
- Carbide measuring faces
- Supplied with setting standards
- Optional accessory: data output cable (code 7315-31 need receiver, 7302-31)

Code	Range	Flutes	Accuracy	α
3590-153A	1-15mm/0.04-0.6"	3	±4μm	60°

### NON-ROTATING SPINDLE UNIVERSAL MICROMETER

NON-ROTATING SPINDLE



3280-25A

Code	Range	Accuracy
3280-25A	0-25mm	4µm

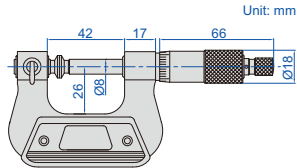

Unit: mm

- Meet DIN863-3
- Graduation 0.01mm
- Non-rotating spindle
- Ratchet stop
- Supplied with 7 pairs of anvil/spindle tip
- Optional accessory: 55° anvil/spindle tip (code 3280-SP1 and 3280-SP2)

Anvil/spindle tip (included) Unit: mm

Flat		
Spherical		
Spline		
Disk		
Blade		
Knife-edge		
Point		

55° anvil/spindle tip (optional) Unit: mm

Code 3280-SP1 Knife-edge		
Code 3280-SP2 Point		

### DIGITAL UNIVERSAL MICROMETER

NON-ROTATING SPINDLE

DATA OUTPUT



3580-25A

Code	Range
3580-25A	0-25mm/0-1"

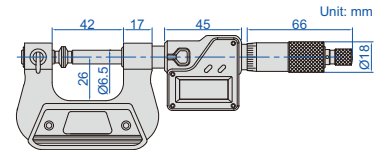

Unit: mm

- Accuracy: ±4µm
- Resolution 0.001mm/0.00005"
- Non-rotating spindle
- Button function: on/off, set, mm/inch, data transmit
- Data output, automatic power off
- Ratchet stop
- Supplied with 7 pairs of anvil/spindle tip
- Optional accessory: 55° anvil/spindle tip code 3280-SP1 and 3280-SP2, data output cable (code 7315-31 need receiver, 7302-31)

Anvil/spindle tip (included) Unit: mm

Flat		
Spherical		
Spline		
Disk		
Blade		
Knife-edge		
Point		

55° anvil/spindle tip (optional) Unit: mm

Code 3280-SP1 Knife-edge		
Code 3280-SP2 Point		

### JAW TYPE MICROMETER

NON-ROTATING SPINDLE

- Graduation 0.01mm
- Non-rotating spindle
- Ratchet stop

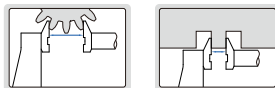

3283-25A

Code	Range	Accuracy
3283-25A	0-25mm	4µm

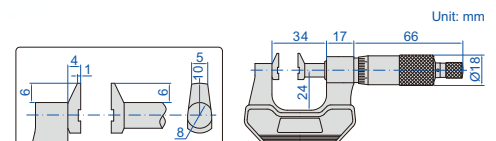

Unit: mm

### DIGITAL JAW TYPE MICROMETER

NON-ROTATING SPINDLE

DATA OUTPUT

- Resolution 0.001mm/0.00005"
- Non-rotating spindle
- Button function: on/off, set, mm/inch, data transmit
- Data output
- Automatic power off
- Ratchet stop
- Optional accessory: data output cable (code 7315-31 need receiver, 7302-31)



3583-25A

(mm)

Code	Range	Accuracy	L	a	b	R	D
3583-25A	0-25mm/0-1"	±4µm	43	6.5	32	10	8

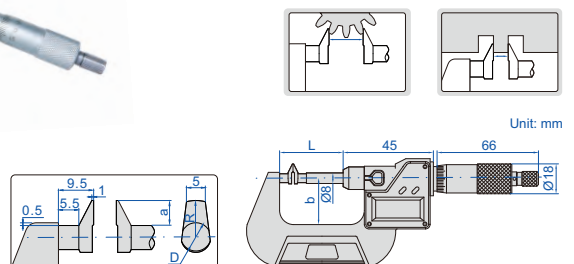

Unit: mm

## CALIPER TYPE MICROMETER

- Graduation 0.01mm
- Non-rotating spindle
- Ratchet stop
- Carbide measuring faces

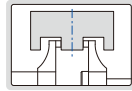

3238-25

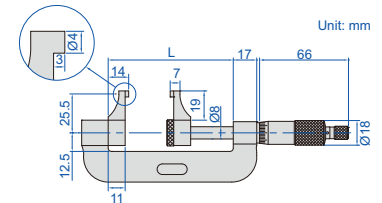

Code	Range	Accuracy	L
3238-25	0-25mm	10µm	56mm

## DISK MICROMETERS



3282-25

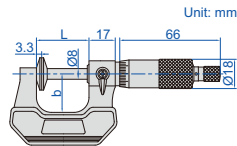

- Measure root tangent length of gear
- Graduation 0.01mm
- Ratchet stop
- Supplied with setting standards

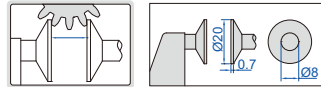

Code	Range	Accuracy	Parallelism	L	b
3282-25	0-25mm	4µm	5µm	34mm	24mm
3282-50	25-50mm	4µm	5µm	59mm	32mm
3282-75	50-75mm	5µm	5µm	85mm	45mm
3282-100	75-100mm	5µm	5µm	110mm	57mm

## DIGITAL NON-ROTATING SPINDLE DISK MICROMETERS

NON-ROTATING SPINDLE

DATA OUTPUT



3594-25A

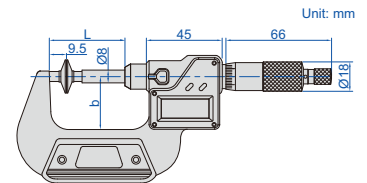
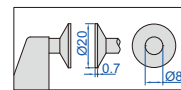

- Measure root tangent length of gear
- Resolution 0.001mm/0.00005"
- Non-rotating spindle
- Button function: on/off, set, mm/inch, data transmit
- Data output
- Automatic power off
- Ratchet stop
- Supplied with setting standards
- Optional accessory: data output cable (code 7315-31 need receiver, 7302-31)

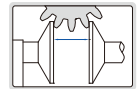

Code	Range	Accuracy	Parallelism	L	b
3594-25A	0-25mm/0-1"	±4µm	5µm	43mm	32mm
3594-50A	25-50mm/1-2"	±4µm	5µm	68mm	44.5mm
3594-75A	50-75mm/2-3"	±5µm	5µm	93mm	57mm
3594-100A	75-100mm/3-4"	±5µm	5µm	118.5mm	70mm

## WIRE MICROMETER



3285-10

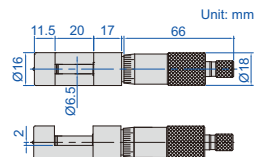

- Meet DIN863-3
- Measure diameter of wires and small balls
- Graduation 0.01mm
- Ratchet stop
- Carbide measuring faces



Code	Range	Accuracy
3285-10	0-10mm	4µm

## CAN SEAM MICROMETERS



3293-131



3293-132



3293-133

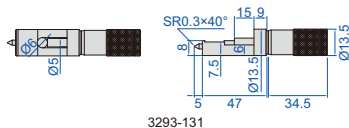

3293-131

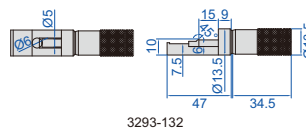

3293-132

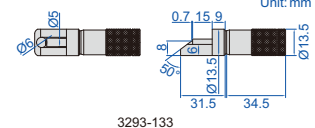

3293-133

- Measure the width, height and depth of can seams
- Graduation 0.01mm

Code	Range	Accuracy
3293-131	0-13mm	4µm
3293-132	0-13mm	4µm
3293-133	0-13mm	4µm

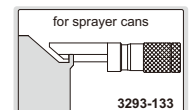
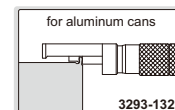
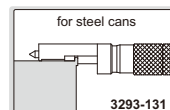

### MICROMETER STAND

- Suitable for outside micrometers up to 100mm

**Code**  
**6300**



**6300**

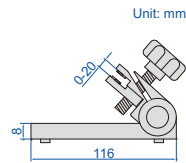

### MICROMETER STAND

- Suitable for outside micrometers up to 100mm

**Code**  
**6301**



**6301**

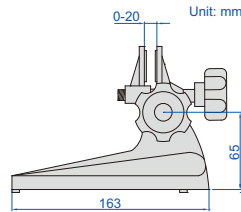

- Suitable for inside micrometers

Code	Description	Applicable products
<b>6301-1</b>	clamp for inside micrometers	all sizes of <b>3220</b> series



**6301-1**

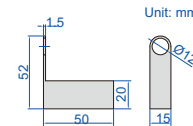

- Suitable for three points internal micrometers

**Code**  
**6301-2**



**6301-2**

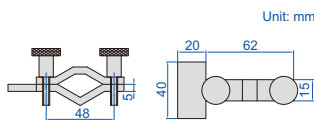

Code	Description	Applicable products
<b>6301-2</b>	clamp for three points internal micrometers	up to 100mm of <b>3127</b> and <b>3227</b> series



### MICROMETER SETTING STANDARDS



**6310-100**



type A



**6310-300**

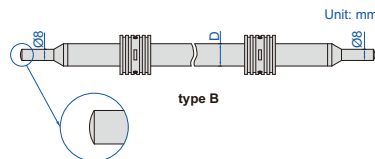

type B

Code	Length	Type	Accuracy	D
<b>6310-25</b>	25	A	±1.5µm	Ø7
<b>6310-50</b>	50	A	±2µm	Ø7
<b>6310-75</b>	75	A	±2.5µm	Ø7
<b>6310-100</b>	100	A	±3µm	Ø8
<b>6310-125</b>	125	A	±3.5µm	Ø8
<b>6310-150</b>	150	A	±4µm	Ø8
<b>6310-175</b>	175	A	±4.5µm	Ø8
<b>6310-200</b>	200	A	±5µm	Ø8
<b>6310-225</b>	225	A	±5.5µm	Ø8
<b>6310-250</b>	250	A	±6µm	Ø8
<b>6310-275</b>	275	A	±6.5µm	Ø8
<b>6310-300</b>	300	B	±7µm	Ø16

### MICROMETER HEAD

- Meet DIN863-2
- Ratchet stop

Code	Range	Stem	Spindle tip	Accuracy	Graduation
<b>6381-25W</b>	0-25mm	plain	flat (carbide)	3µm	0.01mm



**6381-25W**

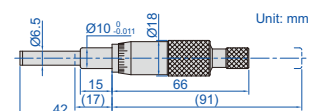

## INSIDE MICROMETERS (ECONOMIC TYPE)

ATTENTION: LOW PARALLELISM OF TWO MEASURING FACES



3220-50

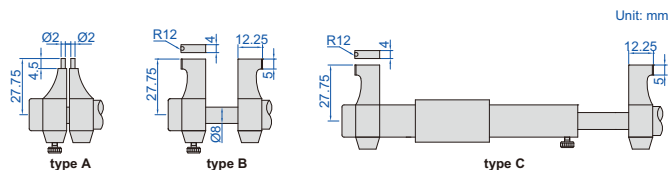

Unit: mm

- Graduation 0.01mm
- Ratchet stop
- Carbide measuring faces
- Optional accessory: setting ring (code 6312), micrometer stand and clamp (code 6301 and 6301-1)

micrometer stand with clamp (optional)



Code	Range	Type	Setting ring	Accuracy
3220-30	5-30mm	A	5mm (included)	7µm
3220-50	25-50mm	B	25mm (included)	8µm
3220-75	50-75mm	B	50mm (optional)	9µm
3220-100	75-100mm	C	75mm (optional)	10µm

## DIGITAL INSIDE MICROMETERS (ECONOMIC TYPE)

ATTENTION: LOW PARALLELISM OF TWO MEASURING FACES



3520-30

DATA OUTPUT

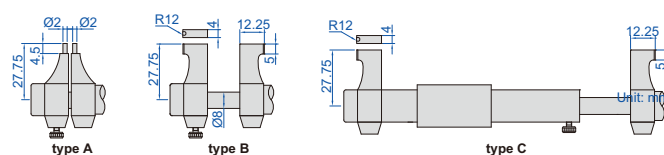

Unit: mm

- Resolution 0.001mm/0.00005"
- Button function: on/off, set, mm/inch, data transmit
- Data output, automatic power off
- Ratchet stop
- Carbide measuring faces
- Optional accessory: data output cable (code 7315-31 need receiver, 7302-31), setting ring (code 6312)

Code	Range	Type	Setting ring	Accuracy
3520-30	5-30mm/0.2-1.2"	A	5mm (included)	±5µm
3520-50	25-50mm/1-2"	B	25mm (included)	±6µm
3520-75	50-75mm/2-3"	B	50mm (optional)	±7µm
3520-100	75-100mm/3-4"	C	75mm (optional)	±8µm

## TUBULAR INSIDE MICROMETERS

- Graduation: 0.01mm
- Accuracy:  $(6+L/50)\mu\text{m}$   
L=maximum measuring length (mm)
- Optional accessory: setting ring (code 6312), gage block accessory (code 6881), cylinder gage block (code 4001), caliper/height gage checker (code 6884)



3221-50

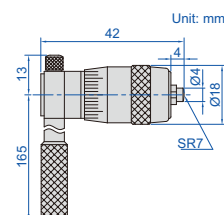

Unit: mm

application

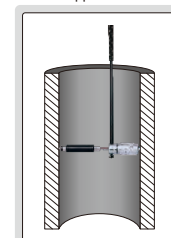

Code	Range	Travel of micrometer head	Extension rods
3221-50	25-50mm	7mm	2 pcs
3221-300	50-300mm	13mm	10 pcs

## TUBULAR INSIDE MICROMETERS

- Micrometer head: 50-63mm
- Travel of micrometer head: 13mm
- Graduation: 0.01mm
- Accuracy:  $(3+n+L/50)\mu\text{m}$   
n=number of rods,  
L=maximum measuring length (mm)
- Supplied with setting standards
- Carbide measuring faces

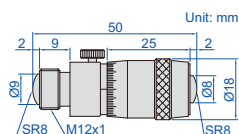

Unit: mm



3222-150

Code	Range	Extension rods
3222-150	50-150mm	13mm, 25mm, 50mm
3222-300	50-300mm	13mm, 25mm, 50mm (2 pcs), 100mm
3222-500	50-500mm	13mm, 25mm, 50mm (2 pcs), 100mm, 200mm
3222-600	50-600mm	13mm, 25mm, 50mm, 100mm, 150mm, 200mm
3222-1000	50-1000mm	13mm, 25mm, 50mm (2 pcs), 100mm, 200mm (2 pcs), 300mm
3222-1500	50-1500mm	13mm, 25mm, 50mm (2 pcs), 100mm, 200mm (3 pcs), 300mm (2 pcs)

## DIGITAL TUBULAR INSIDE MICROMETERS

- Micrometer head: 150-175mm
- Graduation: 0.001mm/0.00005"
- Accuracy:  $(3+n+L/50)\mu\text{m}$   
n= number of rods  
L=maximum measuring length (mm)
- Carbide measuring faces
- The diameter of extension rods is 22mm
- IP65 dust/waterproof
- Button function: on/off, set, mm/inch, data transmit
- Data output
- Automatic power off
- Supplied with setting standards
- Optional accessory: data output cable (code 7315-31 need receiver, 7302-31)



3521-1000

**IP65**  
WATERPROOF

**DATA**  
OUTPUT

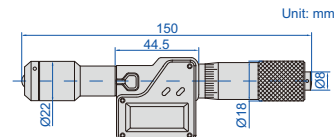

Code	Range	Travel of micrometer head	Extension rods
3521-175	150-175mm	25mm	—
3521-1000	150-1000mm	25mm	25mm, 50mm (2 pcs), 100mm, 200mm, 400mm

## THREE POINTS INTERNAL MICROMETERS



- Meet DIN863-4
- 6-12mm: graduation 0.001mm, 12-200mm: graduation 0.005mm
- Ratchet stop
- Optional accessory: setting rings (code 6312), micrometer stand and clamp (code 6301 and 6301-2)

micrometer stand with clamp (optional)



3227-8

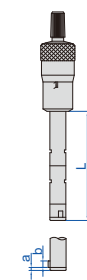

type A  
6-12mm, steel measuring points three points



3227-16

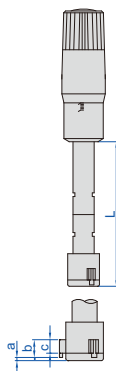

type B  
12-50mm, carbide measuring points three points



3227-125

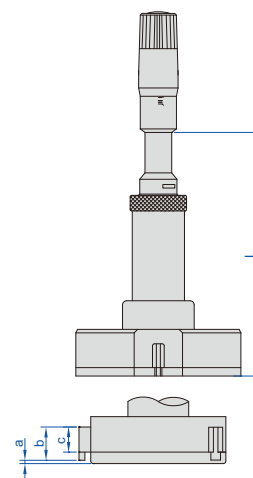

type C  
50-200mm, carbide measuring points three points

### Individual

(mm)

Code	Range	Type	Accuracy	Setting ring	Extension rod (included)	L	a	b	c
3227-8*	6-8mm	A	4 $\mu\text{m}$	Ø6mm (included)	100mm	54.5	1.5	2.5	—
3227-10*	8-10mm	A	4 $\mu\text{m}$	Ø8mm (included)	100mm	54.5	1.5	2.5	—
3227-12*	10-12mm	A	4 $\mu\text{m}$	Ø10mm (included)	100mm	54.5	1.5	2.5	—
3227-16*	12-16mm	B	4 $\mu\text{m}$	Ø16mm (included)	150mm	80	0.5	6	4.5
3227-20*	16-20mm	B	4 $\mu\text{m}$	Ø16mm (included)	150mm	80	0.5	6	4.5
3227-25*	20-25mm	B	4 $\mu\text{m}$	Ø25mm (included)	150mm	90	0.5	8	6
3227-30*	25-30mm	B	4 $\mu\text{m}$	Ø25mm (included)	150mm	90	0.5	8	6
3227-40*	30-40mm	B	4 $\mu\text{m}$	Ø40mm (included)	150mm	97	0.5	14	12
3227-50*	40-50mm	B	5 $\mu\text{m}$	Ø40mm (included)	150mm	97	0.5	14	12
3227-63*	50-63mm	C	5 $\mu\text{m}$	Ø62mm (included)	150mm	114	0.5	17.5	14.5
3227-75*	62-75mm	C	5 $\mu\text{m}$	Ø62mm (included)	150mm	114	0.5	17.5	14.5
3227-88*	75-88mm	C	5 $\mu\text{m}$	Ø87mm (included)	150mm	114	0.5	17.5	14.5
3227-100*	87-100mm	C	5 $\mu\text{m}$	Ø87mm (included)	150mm	114	0.5	17.5	14.5
3227-125*	100-125mm	C	5 $\mu\text{m}$	optional	150mm	140	0.9	29	25
3227-150*	125-150mm	C	5 $\mu\text{m}$	optional	150mm	140	0.9	29	25
3227-175*	150-175mm	C	7 $\mu\text{m}$	optional	150mm	140	0.9	29	25
3227-200*	175-200mm	C	7 $\mu\text{m}$	optional	150mm	140	0.9	29	25

extension rod (included)



setting ring



6-100mm: included  
100-200mm: optional

### Set

Code	Range	Micrometers included	Setting ring (included)	Extension rod (included)
3227-123*	6-12mm	6-8mm, 8-10mm, 10-12mm	Ø6mm, Ø8mm, Ø10mm	100mm
3227-202*	12-20mm	12-16mm, 16-20mm	Ø16mm	150mm
3227-504*	20-50mm	20-25mm, 25-30mm, 30-40mm, 40-50mm	Ø25mm, Ø40mm	150mm
3227-1004*	50-100mm	50-63mm, 62-75mm, 75-88mm, 87-100mm	Ø62mm, Ø87mm	150mm



3227-504

\*Supplied with manufacturer inspection certificate

## DIGITAL THREE POINTS INTERNAL MICROMETERS

**IP65**  
WATERPROOF

**DATA**  
OUTPUT

**INSPECTION**  
CERTIFICATE

- Resolution 0.001mm/0.00005"
- IP65 dust/waterproof
- Buttons: on/off, set, mm/inch, data transmit
- Data output
- Automatic power off
- Ratchet stop
- Optional accessory: data output cable (code **7315-31** need receiver, **7302-31**), setting ring (code **6312**), micrometer stand and clamp (code **6301** and **6301-2**)

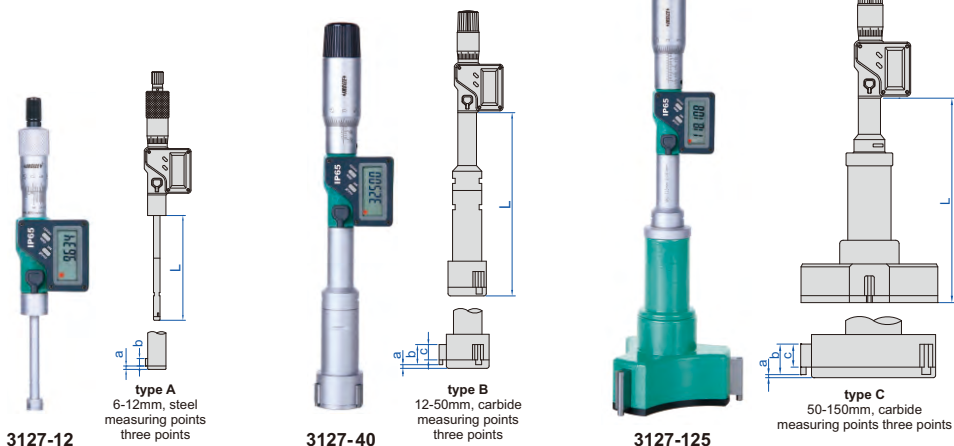

Individual										(mm)
Code	Range	Type	Accuracy	Setting ring	Extension rod (included)	L	a	b	c	
3127-8 *	6-8mm/0.24-0.31"	A	4µm	Ø6mm (included)	100mm	57	1.5	2.5	—	
3127-10 *	8-10mm/0.31-0.39"	A	4µm	Ø8mm (included)	100mm	57	1.5	2.5	—	
3127-12 *	10-12mm/0.39-0.47"	A	4µm	Ø10mm (included)	100mm	57	1.5	2.5	—	
3127-16 *	12-16mm/0.47-0.63"	B	4µm	Ø16mm (included)	150mm	99	0.5	6	4.5	
3127-20 *	16-20mm/0.63-0.79"	B	4µm	Ø16mm (included)	150mm	99	0.5	6	4.5	
3127-25 *	20-25mm/0.79-0.98"	B	4µm	Ø25mm (included)	150mm	105	0.5	8	6	
3127-30 *	25-30mm/0.98-1.18"	B	4µm	Ø25mm (included)	150mm	105	0.5	8	6	
3127-40 *	30-40mm/1.18-1.57"	B	4µm	Ø40mm (included)	150mm	110	0.5	14	12	
3127-50 *	40-50mm/1.57-1.97"	B	5µm	Ø40mm (included)	150mm	110	0.5	14	12	
3127-63 *	50-63mm/1.97-2.48"	C	5µm	Ø62mm (included)	150mm	127	0.5	17.5	14.5	
3127-75 *	62-75mm/2.44-2.95"	C	5µm	Ø62mm (included)	150mm	127	0.5	17.5	14.5	
3127-88 *	75-88mm/2.95-3.46"	C	5µm	Ø87mm (included)	150mm	127	0.5	17.5	14.5	
3127-100 *	87-100mm/3.43-3.94"	C	5µm	Ø87mm (included)	150mm	127	0.5	17.5	14.5	
3127-125 *	100-125mm/3.94-4.92"	C	5µm	optional	150mm	175	0.9	29	25	
3127-150 *	125-150mm/4.92-5.91"	C	5µm	optional	150mm	175	0.9	29	25	

extension rod (included)



setting ring



6-100mm: included  
100-150mm: optional

micrometer stand with clamp (optional)



### Set

Code	Range	Micrometers included	Setting ring (included)	Extension rod (included)
3127-123 *	6-12mm/0.24-0.47"	6-8mm, 8-10mm, 10-12mm	Ø6mm, Ø8mm, Ø10mm	100mm
3127-202 *	12-20mm/0.47-0.79"	12-16mm, 16-20mm	Ø16mm	150mm
3127-504 *	20-50mm/0.79-1.97"	20-25mm, 25-30mm, 30-40mm, 40-50mm	Ø25mm, Ø40mm	150mm
3127-1004 *	50-100mm/1.97-3.94"	50-63mm, 62-75mm, 75-88mm, 87-100mm	Ø62mm, Ø87mm	150mm

\*Supplied with manufacturer inspection certificate



3127-202

## WIDE RANGE THREE POINTS INTERNAL MICROMETERS

- Meet DIN863-4
- Graduation 0.001mm
- Carbide measuring faces
- Ratchet stop
- Setting rings are included

**INSPECTION**  
CERTIFICATE

Code	Range	Accuracy	Setting ring
3228-70 *	50-70mm	5µm	Ø50mm (included)
3228-100 *	70-100mm	5µm	Ø70mm (included)
3228-150 *	100-150mm	6µm	Ø100mm (included)
3228-250 *	150-250mm	8µm	Ø150mm (included)



setting ring

3228-70

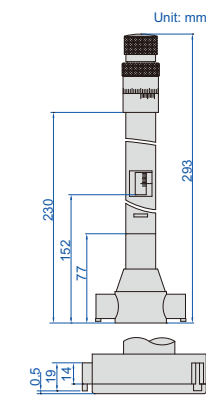

Unit: mm

\*Supplied with manufacturer inspection certificate

## DIGITAL WIDE RANGE THREE POINTS INTERNAL MICROMETERS

**IP54**  
WATERPROOF

**DATA**  
OUTPUT

**INSPECTION**  
CERTIFICATE

- Meet DIN863-4
- Resolution 0.001mm/0.00005" (resolution of **3128-300** is 0.001mm/0.0001")
- IP54 dust/waterproof
- Buttons: on/off, set, mm/inch
- Data output
- Automatic power off
- Carbide measuring faces
- Ratchet stop
- Supplied with extension rods
- Setting rings are included (except 200-300mm)
- Optional accessory: data output cable (code **7315-30** need receiver, **7302-30**)

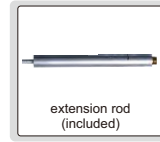

**3128-150**

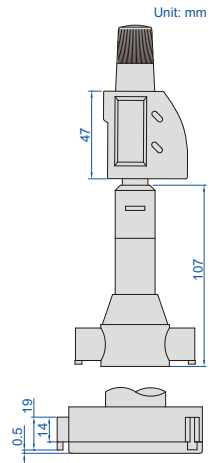

Code	Range	Accuracy	Setting ring	Extension rod (included)
<b>3128-70*</b>	50-70mm/1.97-2.76"	5µm	Ø50mm (included)	150mm
<b>3128-100*</b>	70-100mm/2.76-3.94"	5µm	Ø70mm (included)	150mm
<b>3128-150*</b>	100-150mm/3.94-5.91"	6µm	Ø100mm (included)	150mm
<b>3128-250*</b>	150-250mm/5.91-9.84"	8µm	Ø150mm (included)	150mm
<b>3128-300*</b>	200-300mm/7.87-11.81"	9µm	Ø200mm (optional)	150mm

\*Supplied with manufacturer inspection certificate

## PISTOL GRIP THREE POINTS BORE GAGES

**INSPECTION**  
CERTIFICATE

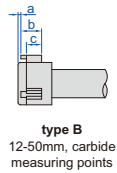
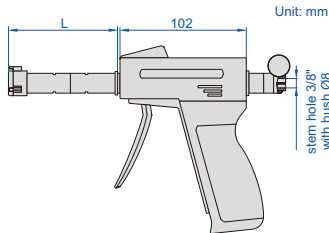

**type B**  
12-50mm, carbide measuring points



**2124-25**

digital indicator is optional

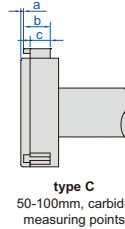

**type C**  
50-100mm, carbide measuring points

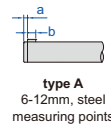

**type A**  
6-12mm, steel measuring points



**2124-8**

digital indicator is optional



**2124-100**

digital indicator is optional

### Individual

Code	Range	Type	Accuracy (without digital indicator)	Setting ring (included)	Extension rod (included)	L	a	b	c
<b>2124-8*</b>	6-8mm	A	4µm	Ø6mm	100mm	50	1.5	2.5	—
<b>2124-10*</b>	8-10mm	A	4µm	Ø8mm	100mm	50	1.5	2.5	—
<b>2124-12*</b>	10-12mm	A	4µm	Ø10mm	100mm	50	1.5	2.5	—
<b>2124-16*</b>	12-16mm	B	4µm	Ø16mm	150mm	65	0.5	6	4.5
<b>2124-20*</b>	16-20mm	B	4µm	Ø16mm	150mm	65	0.5	6	4.5
<b>2124-25*</b>	20-25mm	B	4µm	Ø25mm	150mm	91	0.5	8	6
<b>2124-30*</b>	25-30mm	B	4µm	Ø25mm	150mm	91	0.5	8	6
<b>2124-40*</b>	30-40mm	B	4µm	Ø40mm	150mm	97	0.5	14	12
<b>2124-50*</b>	40-50mm	B	5µm	Ø40mm	150mm	97	0.5	14	12
<b>2124-63*</b>	50-63mm	C	5µm	Ø62mm	150mm	112	0.5	17.5	14.5
<b>2124-75*</b>	62-75mm	C	5µm	Ø62mm	150mm	112	0.5	17.5	14.5
<b>2124-88*</b>	75-88mm	C	5µm	Ø87mm	150mm	112	0.5	17.5	14.5
<b>2124-100*</b>	87-100mm	C	5µm	Ø87mm	150mm	112	0.5	17.5	14.5

- Optional accessory: digital indicators (code **2108-101F**, resolution 0.001mm/0.00005"), setting rings (code **6312**)

setting ring (included)



extension rod (included)



### Set

Code	Range	Probes included	Setting ring (included)	Extension rod (included)
<b>2124-S123*</b>	6-12mm	6-8mm, 8-10mm, 10-12mm	Ø6mm, Ø8mm, Ø10mm	100mm
<b>2124-S202*</b>	12-20mm	12-16mm, 16-20mm	Ø16mm	150mm
<b>2124-S504*</b>	20-50mm	20-25mm, 25-30mm, 30-40mm, 40-50mm	Ø25mm, Ø40mm	150mm
<b>2124-S1004*</b>	50-100mm	50-63mm, 62-75mm, 75-88mm, 87-100mm	Ø62mm, Ø87mm	150mm



**2124-S504**

\*Supplied with manufacturer inspection certificate



## PRECISION BORE GAGES FOR SMALL HOLES (WITH DIAL INDICATOR)

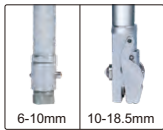

- Accuracy:  $\pm 0.007\text{mm}$
- Optional accessory: setting ring (code 6312), bore gage setter

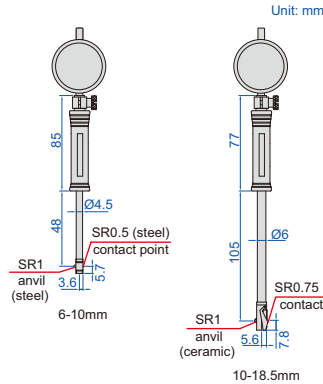

2853-10



2153-18

### With dial indicator

Code	Range	Indicator	Repeatability
2853-10	6-10mm	dial indicator, range 1mm, graduation 0.001mm (code 2313-1FA)	0.0015mm
2853-18	10-18.5mm		0.0015mm

### With digital indicator

(data output cable code 7315-50M need receiver, 7302-40M, optional)

Code	Range	Indicator	Repeatability
2153-10	6-10mm	digital indicator, code 2108-101F, range 12.7mm/0.5", resolution 0.001mm/0.00005"	0.002mm
2153-18	10-18.5mm		0.002mm

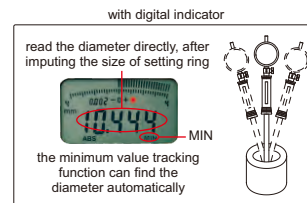

## PRECISION BORE GAGES (WITH DIAL INDICATOR)

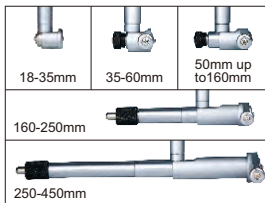

### with digital indicator

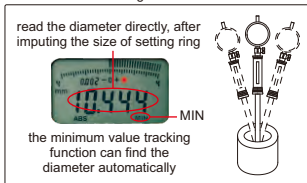

2825-160



2126-35

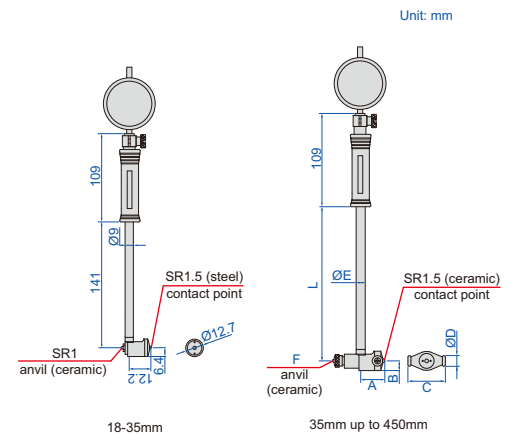

Range	A	B	C	ØD	ØE	F	L
35-60mm	22	9	27	13	12.8	SR2	141
50-100mm	26	9	35	13	12.8	SR2	141
50-160mm	26	9	35	13	12.8	SR2	141
100-160mm	26	9	35	13	12.8	SR2	141
160-250mm	56.5	13	74.5	15	12.8	SR2	241
250-450mm	86.5	15	101.5	15	14.5	SR2.5	241

- Optional accessory: setting ring (code 6312), bore gage setter

### With dial indicator

Code	Range	Indicator	Accuracy	Repeatability
2825-35	18-35mm	dial indicator, range 1mm, graduation 0.001mm (code 2313-1FA)	$\pm 0.007\text{mm}$	0.0015mm
2825-60	35-60mm		$\pm 0.007\text{mm}$	0.0015mm
2825-100	50-100mm		$\pm 0.007\text{mm}$	0.0015mm
2825-160	50-160mm		$\pm 0.007\text{mm}$	0.0015mm
2825-161	100-160mm		$\pm 0.007\text{mm}$	0.0015mm
2825-250	160-250mm		$\pm 0.007\text{mm}$	0.0015mm
2825-450	250-450mm		$\pm 0.007\text{mm}$	0.0015mm

### With digital indicator

(data output cable code 7315-50M need receiver, 7302-40M, optional)

Code	Range	Indicator	Accuracy	Repeatability
2126-35	18-35mm	digital indicator, code 2108-101F, range 12.7mm/0.5", resolution 0.001mm/0.00005"	$\pm 0.007\text{mm}$	0.002mm
2126-60	35-60mm		$\pm 0.007\text{mm}$	0.002mm
2126-100	50-100mm		$\pm 0.007\text{mm}$	0.002mm
2126-160	50-160mm		$\pm 0.007\text{mm}$	0.002mm
2126-161	100-160mm		$\pm 0.007\text{mm}$	0.002mm
2126-250	160-250mm		$\pm 0.007\text{mm}$	0.002mm
2126-450	250-450mm		$\pm 0.007\text{mm}$	0.002mm

**BORE GAGES FOR SMALL HOLES (WITH DIAL INDICATOR)**

**ATTENTION: NOT SUITABLE FOR 0.001MM DIAL INDICATORS**

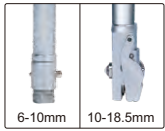

- Repeatability: 0.003mm
- Optional accessory: setting ring (code 6312), bore gage setter

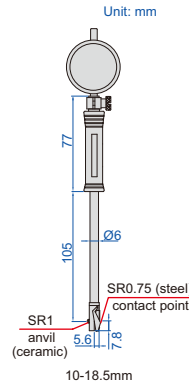
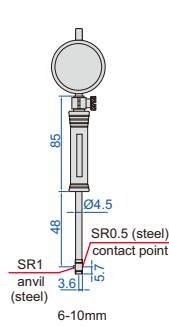

2852-10



2152-18

**With dial indicator**

Code	Range	Indicator	Accuracy
2852-10	6-10mm	dial indicator, range 3mm, graduation 0.01mm (code 2311-3F)	±0.012mm
2852-18	10-18.5mm	dial indicator, range 3mm, graduation 0.01mm (code 2311-3F)	±0.012mm

**With digital indicator**

(data output cable code 7315-50M need receiver, 7302-40M, optional)

Code	Range	Indicator	Accuracy
2152-10	6-10mm	digital indicator, code 2108-10F, range 12.7mm/0.5", resolution 0.002mm/0.0001" (can switch to: 0.01mm/0.0005")	±0.012mm
2152-18	10-18.5mm	digital indicator, code 2108-10F, range 12.7mm/0.5", resolution 0.002mm/0.0001" (can switch to: 0.01mm/0.0005")	±0.012mm

with digital indicator

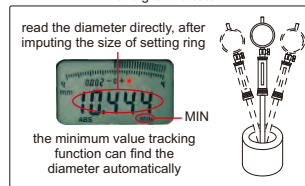

**BORE GAGES (WITH DIAL INDICATOR)**

**ATTENTION: NOT SUITABLE FOR 0.001MM DIAL INDICATORS**

**POPULAR MODEL**

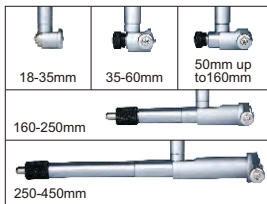

with digital indicator

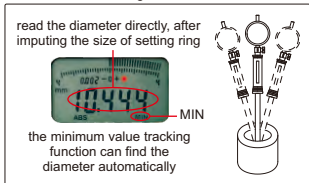

- Repeatability: 0.003mm
- Optional accessory: setting ring (code 6312), long handle (code 7351), bore gage setter



2322-160A



2122-35A

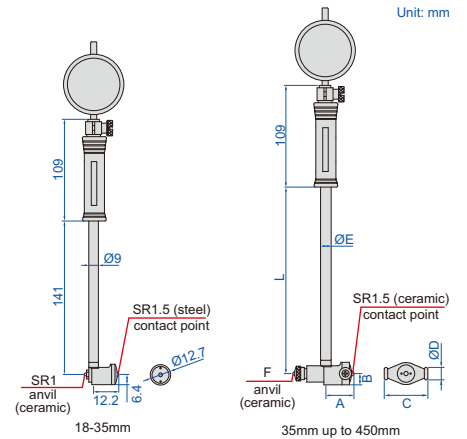

Range	A	B	C	ØD	ØE	F	L
35-60mm	22	9	27	13	12.8	SR2	141
50-100mm	26	9	35	13	12.8	SR2	141
50-160mm	26	9	35	13	12.8	SR2	141
100-160mm	26	9	35	13	12.8	SR2	141
160-250mm	56.5	13	74.5	15	12.8	SR2	241
250-450mm	86.5	15	101.5	15	14.5	SR2.5	241

**With dial indicator**

Code	Range	Indicator	Accuracy
2322-35A	18-35mm	dial indicator, range 10mm, graduation 0.01mm (code 2308-10FA)	±0.015mm
2322-60A	35-60mm		±0.018mm
2322-100A	50-100mm		±0.018mm
2322-160A	50-160mm		±0.018mm
2322-161A	100-160mm		±0.018mm
2322-250A	160-250mm		±0.018mm
2322-450A	250-450mm	±0.018mm	

**With digital indicator**

(data output cable code 7315-50M need receiver, 7302-40M, optional)

Code	Range	Indicator	Accuracy
2122-35A	18-35mm	digital indicator, code 2108-10F, range 12.7mm/0.5", resolution 0.002mm/0.0001" (can switch to: 0.01mm/0.0005")	±0.015mm
2122-60A	35-60mm		±0.018mm
2122-160A	50-160mm		±0.018mm
2122-250A	160-250mm		±0.018mm
2122-450A	250-450mm		±0.018mm

## BORE GAGE (WITH DIAL INDICATOR)

ATTENTION: NOT SUITABLE  
FOR 0.001MM DIAL INDICATORS

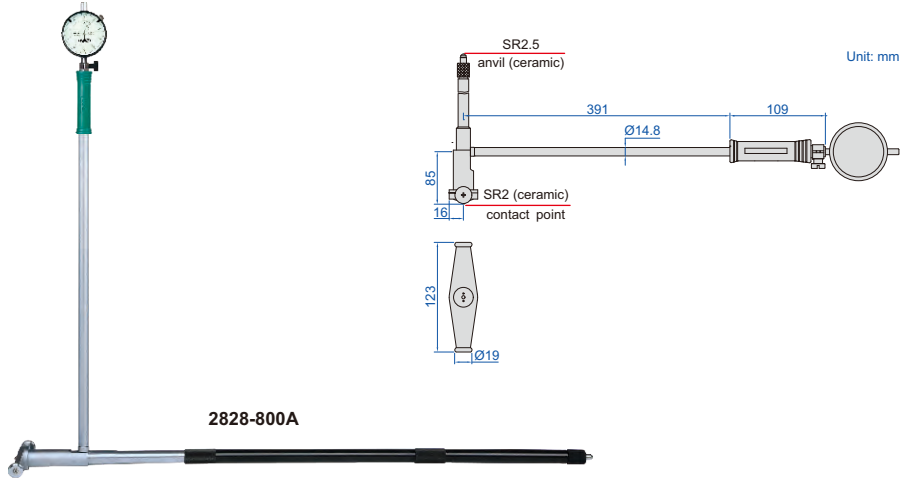

2828-800A

Code	Range	Accuracy	Repeatability	Indicator
2828-800A	400-800mm	±0.025mm	0.003mm	dial indicator, code 2308-10FA, range 10mm, graduation 0.01mm

## BORE GAGE SETS (WITH DIAL INDICATOR)

ATTENTION: NOT SUITABLE  
FOR 0.001MM DIAL INDICATORS

packaging (code 2824-S3)



- Repeatability: 0.003mm
- Optional accessory: setting ring (code 6312), long handle (code 7351), bore gage setter



Code	Range	Indicator	Bore gages included	Accuracy
2824-S160	35-160mm	dial indicator, code 2308-10FA, range 10mm, graduation 0.01mm	① 35-50mm (dial indicator and handle are not included) ② 50-160mm	35-50mm ±0.018mm 50-160mm ±0.018mm
2824-S3	18-160mm	dial indicator, code 2308-10FA, range 10mm, graduation 0.01mm	① 18-35mm ② 35-60mm (dial indicator is not included) ③ 50-160mm (dial indicator is not included)	18-35mm ±0.015mm 35-60mm ±0.018mm 50-160mm ±0.018mm

## LONG HANDLES

- To assist deep-hole measurement
- Can be used for bore gages 2322, 2122, 2824 and 2827

method of use (replace the original handle with long handle)

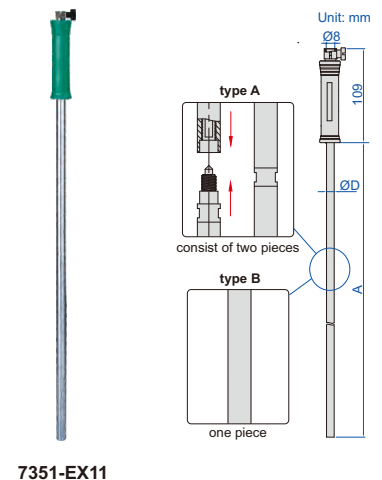
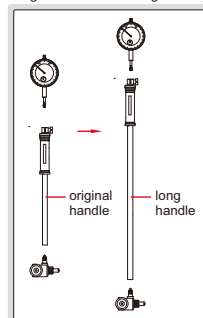

7351-EX11

Code	Applicable bore gages	A	ØD	Type
7351-EX11	35-60mm, 50-100mm, 50-160mm, 100-160mm	475mm	13mm	B
7351-EX12		980mm	13mm	
7351-EX13		1480mm	14.5mm	A
7351-EX14		1980mm	14.5mm	
7351-EX21	160-250mm, 250-450mm	480mm	14.5mm	B
7351-EX22		980mm	14.5mm	
7351-EX23		1480mm	14.5mm	A
7351-EX24		1980mm	14.5mm	

**BORE GAGE SETTERS**

- Vertical and horizontal use
- To be used with gage blocks



**Gage block set for 7353-160**

Blocks per set	Size (mm)	Step (mm)	Quantity	Remark	
33	1.005	0.01	1 pc	grade 2 (ISO3650)	
	1.01-1.09		9 pcs		
	1.1-1.9		9 pcs		
	1-9		1		
	10-30		10		3 pcs
	50		1 pc		
	100		1 pc		

7353-160

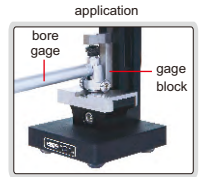
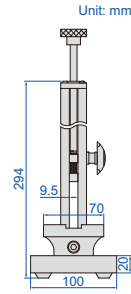

gage blocks for 7353-160

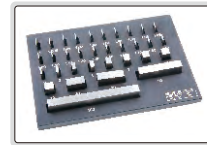

horizontal use

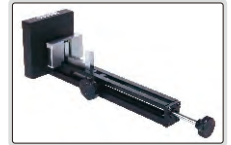

Code	Range	Repeatability	Remark
7353-160	0-160mm	1.2µm	with gage block set
7353-160W	0-160mm	1.2µm	without gage block set

**TELESCOPING GAGE SET**

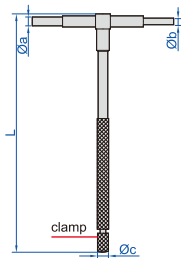

4206-1

Range	L	Øa	Øb	Øc
8-12.7mm	115	3.9	2.9	6.2
12.7-19mm	115	5.3	3.8	6.2
19-32mm	115	5.3	3.8	6.2
32-54mm	137	7.6	6.1	7.2
54-90mm	137	7.6	6.1	7.2
90-150mm	137	7.6	6.1	7.2

- 6 gages per set
- For quick measurement of inside diameter of holes and width of slots
- Satin chrome finish

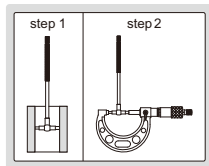

Code	Total range	Gages included (mm)
4206-1	8-150mm	8-12.7, 12.7-19, 19-32, 32-54, 54-90, 90-150

**SMALL HOLE GAGE SET**



4208-1

- 4 gages per set
- For small holes, slots and grooves, etc.
- Satin chrome finish

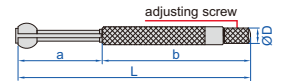

Range	L	a	b	ØD
3-5mm	76	24	52	5
5-7.5mm	79	27	52	5
7.5-10mm	88	30	58	6
10-13mm	91	34	58	6

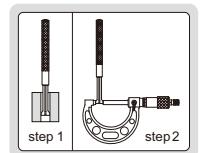

Code	Total range	Gages included
4208-1	3-13mm	3-5mm, 5-7.5mm, 7.5-10mm, 10-13mm

**LONG HANDLE TELESCOPING GAGES**

- For quick measurement of inside diameter of deep holes and width of slots
- Satin chrome finish

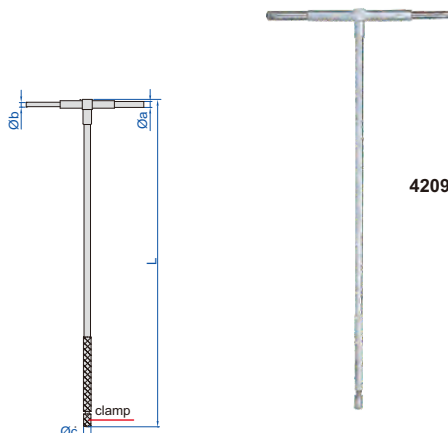

4209-6

Code	Range	L	Øa	Øb	Øc
4209-1	8-12.7mm	300	3.9	2.9	6.2
4209-2	12.7-19mm	300	5.3	3.8	6.2
4209-3	19-32mm	300	5.3	3.8	6.2
4209-4	32-54mm	300	7.6	6.1	7.2
4209-5	54-90mm	300	7.6	6.1	7.2
4209-6	90-150mm	300	7.6	6.1	7.2

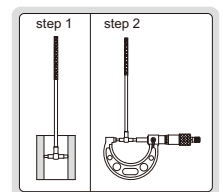

## FLEXIBLE INNER DIAMETER METERS

- Measure average inner diameter of flexible materials
- Made of PET

Code	Diameter range	Graduation	Accuracy
7137-30	Ø10-30mm	0.05mm	±0.10mm
7137-60	Ø30-60mm	0.05mm	±0.10mm
7137-100	Ø50-100mm	0.05mm	±0.10mm
7137-200	Ø100-200mm	0.05mm	±0.10mm
7137-350	Ø200-350mm	0.05mm	±0.15mm



7137-60



application



## DIAMETER METERS

- Measure diameter of pipes, trees, tires, etc.
- Made of stainless steel



7135-525

CAN BE CUSTOM-MADE



Code	Diameter range	Graduation	Accuracy
7135-35 *	Ø20-35mm	0.05mm	±0.05mm
7135-55 *	Ø30-55mm	0.05mm	±0.05mm
7135-125	Ø50-125mm	0.01mm	±0.05mm
7135-225	Ø100-225mm	0.01mm	±0.05mm
7135-375	Ø200-375mm	0.01mm	±0.05mm
7135-525	Ø350-525mm	0.01mm	±0.05mm
7135-725	Ø500-725mm	0.01mm	±0.06mm
7135-925	Ø700-925mm	0.01mm	±0.06mm
7135-1125	Ø900-1125mm	0.02mm	±0.06mm
7135-1325	Ø1100-1325mm	0.02mm	±0.08mm
7135-1525	Ø1300-1525mm	0.02mm	±0.08mm
7135-1725	Ø1500-1725mm	0.02mm	±0.08mm
7135-1925	Ø1700-1925mm	0.02mm	±0.08mm
7135-2125	Ø1900-2125mm	0.02mm	±0.08mm
7135-2325	Ø2100-2325mm	0.02mm	±0.10mm
7135-2525	Ø2300-2525mm	0.02mm	±0.10mm
7135-2750	Ø2500-2750mm	0.02mm	±0.10mm
7135-3000	Ø2750-3000mm	0.02mm	±0.10mm
7135-3250	Ø3000-3250mm	0.02mm	±0.15mm
7135-3500	Ø3250-3500mm	0.02mm	±0.15mm

Code	Diameter range	Graduation	Accuracy
7135-3750	Ø3500-3750mm	0.02mm	±0.15mm
7135-4000	Ø3750-4000mm	0.02mm	±0.20mm
7135-4250	Ø4000-4250mm	0.02mm	±0.20mm
7135-4500	Ø4250-4500mm	0.02mm	±0.20mm
7135-4750	Ø4500-4750mm	0.02mm	±0.20mm
7135-5000	Ø4750-5000mm	0.02mm	±0.20mm
7135-5250	Ø5000-5250mm	0.02mm	±0.005%L **
7135-5500	Ø5250-5500mm	0.02mm	±0.005%L **
7135-5750	Ø5500-5750mm	0.02mm	±0.005%L **
7135-6000	Ø5750-6000mm	0.02mm	±0.005%L **
7135-6250	Ø6000-6250mm	0.02mm	±0.005%L **
7135-6500	Ø6250-6500mm	0.02mm	±0.005%L **
7135-6750	Ø6500-6750mm	0.02mm	±0.005%L **
7135-7000	Ø6750-7000mm	0.02mm	±0.005%L **
7135-7250	Ø7000-7250mm	0.02mm	±0.005%L **
7135-7500	Ø7250-7500mm	0.02mm	±0.005%L **
7135-7750	Ø7500-7750mm	0.02mm	±0.005%L **
7135-8000	Ø7750-8000mm	0.02mm	±0.005%L **
7135-8250	Ø8000-8250mm	0.02mm	±0.005%L **

\*\* L is the actual measured value (unit: mm)

\* The thickness of code 7135-35 and 7135-55 is 0.10mm, while the thickness of other codes is 0.25mm

## CIRCUMFERENCE METERS (ECONOMIC TYPE)

- Measure diameter and circumference of pipes, trees, tires, etc.
- Graduation: 0.1mm
- Laser engraved scale
- Made of stainless steel



7114-950

Code	Circumference range	Diameter range	Accuracy	
			Circumference	Diameter
7114-950	150-950mm	Ø50-300mm	±3mm	±1mm
7114-2200	940-2200mm	Ø300-700mm	±3mm	±1mm
7114-3460	2190-3460mm	Ø700-1100mm	±3mm	±1mm

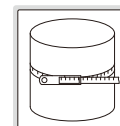
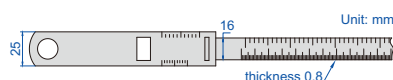

## CIRCUMFERENCE METERS

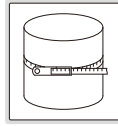

CAN BE CUSTOM-MADE

- Measure diameter and circumference of pipes, trees, tires, etc.
- Made of stainless steel

Code	Circumference range	Diameter range	Graduation	Accuracy	
				circumference	diameter
7136-940	160-940mm	Ø50-300mm	0.1mm	±0.30mm	±0.10mm
7136-1880	940-1880mm	Ø300-600mm	0.1mm	±0.30mm	±0.10mm
7136-2830	1880-2830mm	Ø600-900mm	0.1mm	±0.30mm	±0.10mm
7136-3770	2830-3770mm	Ø900-1200mm	0.1mm	±0.30mm	±0.10mm
7136-4710	3770-4710mm	Ø1200-1500mm	0.1mm	±0.30mm	±0.10mm
7136-5650	4710-5650mm	Ø1500-1800mm	0.1mm	±0.30mm	±0.10mm
7136-6600	5650-6600mm	Ø1800-2100mm	0.1mm	±0.30mm	±0.10mm
7136-7540	6600-7540mm	Ø2100-2400mm	0.1mm	±0.30mm	±0.10mm
7136-8480	7540-8480mm	Ø2400-2700mm	0.1mm	±0.30mm	±0.10mm
7136-9430	8480-9430mm	Ø2700-3000mm	0.1mm	±0.30mm	±0.10mm



7136-1880

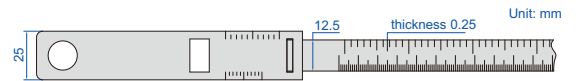

## LARGE RANGE DIGITAL RADIUS GAGE

Unit: mm

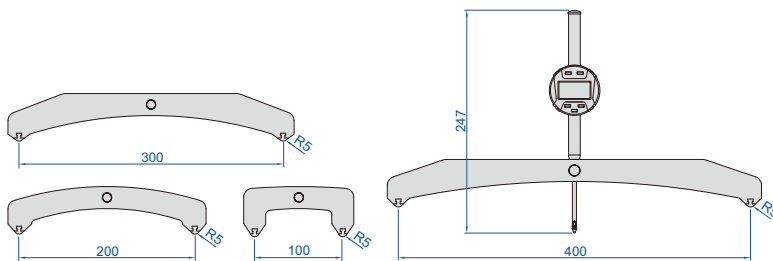

- Measure radius of internal or external arcs
- Resolution: 0.01mm/0.001"
- Buttons: on/off, hold, mm/inch, s (select jaws), zero
- Display can be rotated by 320°
- Supplied with 4 jaws for different sizes of arc
- Battery CR2032, automatic power off (time is adjustable)
- Data output
- Optional accessory: data output cable (code 7315-2183 need receiver, 7302-2183)

Code	Range of external radius (R1)	Range of internal radius (R2)	Accuracy (mm)
2197	100-15000mm/4-590"	100-15000mm/4-590"	±0.005R*

\*R is the radius to be measured. For example, radius is 100mm, the accuracy is ±0.005x100=±0.5mm

DATA OUTPUT



2197

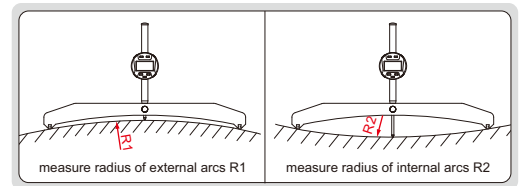

## DIGITAL RADIUS GAGE (LOW ACCURACY)

- Resolution: 0.01mm/0.001"
- Buttons: on/off, hold, mm/inch, s (select jaws), zero
- Measure radius of internal or external arcs
- Display can be rotated by 320°
- Supplied with 5 jaws for different sizes of arc
- Data output, battery CR2032
- Automatic power off (time is adjustable)
- Optional accessory: calibration standard (code 2183-BLOCK), data output cable (code 7315-2183 need receiver, 7302-2183)

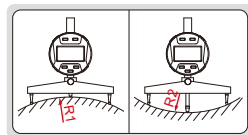

DATA OUTPUT



2183

Code	Range of external radius (R1)	Range of internal radius (R2)	Accuracy (mm)
2183	5-910mm/0.2-35.83"	7-910mm/0.3-35.83"	±0.01R*

\*R is the radius to be measured. For example, radius is 100mm, the accuracy is ±0.01x100=±1mm

### Calibration standard (optional)

Code	Remark
2183-BLOCK	includes 5 standard blocks



2183-BLOCK

calibration standard application

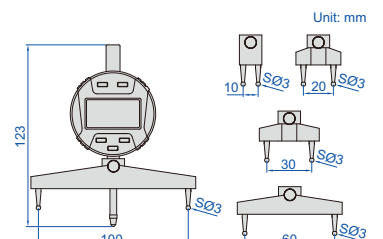

## DIGITAL RADIUS GAGE

- Resolution: 0.01mm/0.001"
- Buttons: on/off, hold, mm/inch, s (select jaws), zero
- Measure radius of internal or external arcs
- Cylindrical measuring jaws, self-positioning
- Display can be rotated by 320°
- Supplied with 5 jaws for different sizes of arc
- Data output, battery CR2032
- Automatic power off (time is adjustable)
- Optional accessory: calibration standard (code **2183-BLOCK**), data output cable (code **7315-2183** need receiver, **7302-2183**)

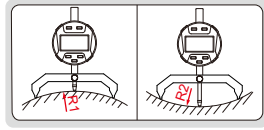

2511

DATA OUTPUT

Code	Range of external radius (R1)	Range of internal radius (R2)	Accuracy (mm)
2511	5-910mm/0.2-35.83"	7-910mm/0.3-35.83"	±0.005R*

\*R is the radius to be measured. For example, radius is 100mm, the accuracy is ±0.005x100=±0.5mm

### Calibration standard (optional)

Code	Remark
2183-BLOCK	includes 5 standard blocks



2183-BLOCK



calibration standard application



VIDEO

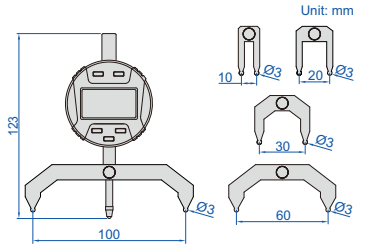

Unit: mm

## DIGITAL RADIUS GAGES

- Measure radius of external arc, arc angle of measured surface should be larger than 60°
- Display radius value, no need to calculate
- Button function: on/off, zero, data preset, inch/mm
- Keep preset data in memory after restart
- CR2032 battery, automatic power off (time is adjustable)
- Data output
- Stainless steel base
- Optional accessory: setting standards, data output cable (code **7315-50M** need receiver, **7302-40M**)



2188-55



2188-233

DATA OUTPUT

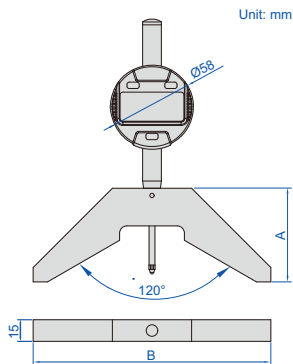

Unit: mm



2188-143



2188-323

Code	Range (radius)	Resolution	Accuracy	A	B
2188-55	4-53mm/0.16-2.09"	0.01mm/0.0005"	±0.02mm	40mm	65mm
2188-143	48-143mm/1.89-5.63"	0.01mm/0.0005"	±0.03mm	65mm	165mm
2188-233	138-233mm/5.43-9.17"	0.01mm/0.0005"	±0.03mm	85mm	255mm
2188-323	228-323mm/8.98-12.72"	0.01mm/0.0005"	±0.04mm	95mm	345mm



VIDEO

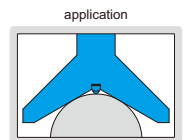

application

### Setting standards

Code	Setting standards	Remark
4110-10D00	setting standard for 2188-55	included
2188-P143	setting standard for 2188-143	optional
2188-P233	setting standard for 2188-233	optional
2188-P323	setting standard for 2188-323	optional



2188-P143



setting standard application

## DIGITAL ARC RADIUS CALIPERS

DATA OUTPUT

- Non waterproof
- Measure the radius of arc less than half round
- Resolution: 0.01mm/0.0005"
- Buttons: on/off, zero, mm/inch
- Automatic power off, move the digital unit to turn on power
- Battery CR2032, data output
- Made of stainless steel



1189-200B

With data interface  
(data output cable code 7315-21 need receiver, 7302-21, optional)

Code	Range (R)	Accuracy	L	c	d
1189-150B	5-150mm/0.2-6"	±0.05mm	263mm	16mm	65mm
1189-200B	5-200mm/0.2-8"	±0.07mm	313mm	16mm	85mm

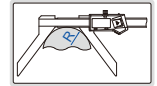
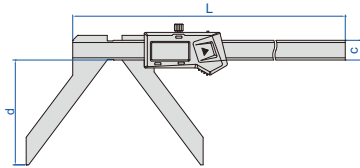

## DIGITAL RADIUS CALIPERS

DIRECT READING,  
CALCULATION IS NOT REQUIRED

DATA OUTPUT

- Non waterproof
- Measure radius of external arc, arc angle of measured surface should be larger than 90°
- Resolution: 0.01mm/0.0005"
- Buttons: on/off, zero, mm/inch
- Automatic power off, move the digital unit to turn on power
- Battery CR2032, data output
- Made of stainless steel
- Supplied with pin gage for zero setting
- Optional accessory: data output cable (code 7315-21 need receiver, 7302-21)



1501-25

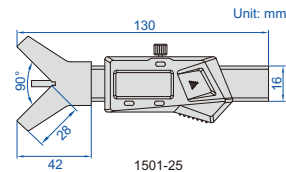

1501-25



VIDEO

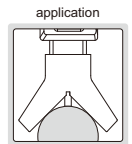

application



1501-10

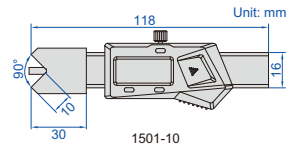

1501-10



pin gage (included)



1501-10 can measure small workpieces or workpieces with steps

Code	Range (radius)	Accuracy
1501-25	2-25mm/0.079-1"	±0.05mm
1501-10	2-10mm/0.079-0.394"	±0.05mm

## CHAMFER GAGE

- Accuracy: ±0.25mm
- To measure internal and external chamfers
- Made of stainless steel

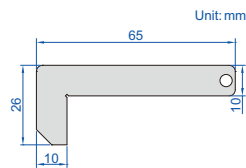

4844-1

for internal chamfer measurement, diameter should be larger than Ø11mm

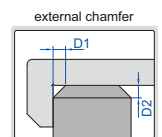
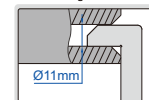

external chamfer

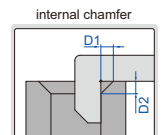

internal chamfer

Code	Graduation
4844-1	0.5mm

## CHAMFER GAGES

- Measure 30°/45°/60° chamfer dimension
- Accuracy: ±0.06mm
- Graduation: 0.02mm
- Made of stainless steel
- Satin chrome plated reading surface

Code	Range	Chamfer (α)	ØD
1267-6	0-10mm	45°	7mm
1267-63	0-10mm	30°	8mm
1267-66	0-10mm	60°	7mm

for internal chamfer measurement, diameter should be larger than ØD

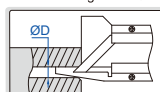

1267-6

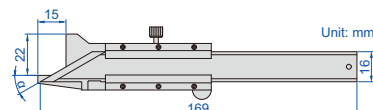

measure chamfer dimension

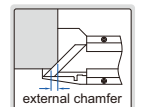

external chamfer

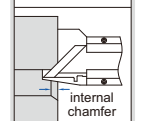

internal chamfer



## DIGITAL CHAMFER GAGES

- Non waterproof
- Measure 30°/45°/60° chamfer dimension
- Resolution: 0.01mm/0.0005"
- Buttons: on/off, zero, mm/inch
- Automatic power off, move the digital unit to turn on power
- Battery CR2032, data output
- Made of stainless steel
- Optional accessory: data output cable (code 7315-21 need receiver, 7302-21)

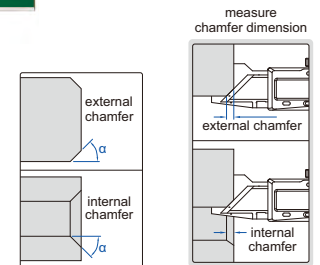
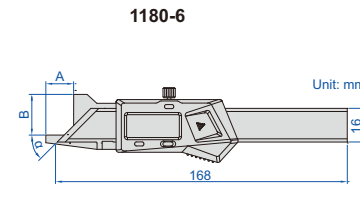
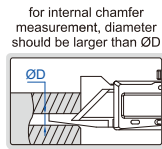

DATA OUTPUT

Code	Range	Accuracy	Chamfer (α)	A	B	ØD
1180-6	0-10mm/0-0.39"	±0.06mm	45°	15mm	22mm	7mm
1180-63	0-10mm/0-0.39"	±0.06mm	30°	15mm	22mm	8mm
1180-66	0-10mm/0-0.39"	±0.06mm	60°	14mm	21mm	7mm

## DIGITAL CHAMFER GAGES



DATA OUTPUT

ATTENTION: CHAMFER OF HOLES CANNOT BE MEASURED

DIRECT READING, CALCULATION IS NOT REQUIRED



1537-20

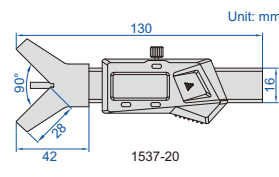

1537-8

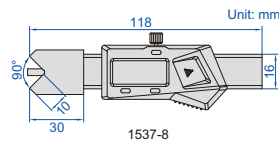

- Non waterproof
- Measure 45° chamfer length
- Resolution: 0.01mm/0.0005"
- Buttons: on/off, zero, mm/inch
- Automatic power off, move the digital unit to turn on power
- Battery CR2032, data output
- Made of stainless steel
- Supplied with pin gage for zero setting
- Optional accessory: data output cable (code 7315-21 need receiver, 7302-21)

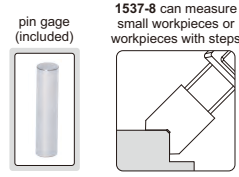

Code	Range	Accuracy
1537-20	0-20mm/0-0.787"	±0.05mm
1537-8	0-8mm/0-0.315"	±0.05mm

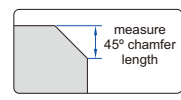

## DIAL TEST INDICATORS

INSPECTION CERTIFICATE

JEWELLED BEARING

POPULAR MODEL



2380-08

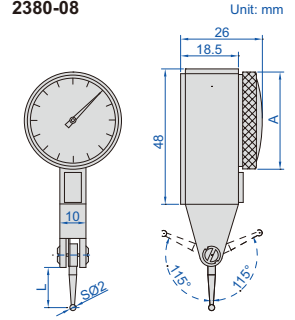
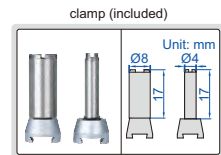

- Meet DIN2270 (except 2380-02, 2381-02, 2381-021)
- Jeweled bearing
- Carbide contact point
- Two measuring directions
- Anti magnetic body
- Supplied with two clamps: diameter Ø4mm and Ø8mm
- Optional accessory: styli

Graduation: 0.01mm

Code	Range	Accuracy	Hysteresis	Dial reading	A	L
2380-08*	0.8mm	13µm	3µm	0-40-0	Ø30mm	13.5mm
2381-08*	0.8mm	13µm	3µm	0-40-0	Ø37mm	13.5mm

Graduation: 0.002mm

Code	Range	Accuracy	Hysteresis	Dial reading	A	L
2380-02*	0.2mm	6µm	2µm	0-100-0	Ø30mm	12.5mm
2381-02*	0.2mm	6µm	2µm	0-100-0	Ø37mm	12.5mm

Graduation: 0.001mm

Code	Range	Accuracy	Hysteresis	Dial reading	A	L
2381-021*	0.2mm	6µm	2µm	0-100-0	Ø37mm	12.5mm

\*Supplied with manufacturer inspection certificate

## LONG STYLUS DIAL TEST INDICATOR

JEWELLED BEARING

INSPECTION CERTIFICATE

- Meet DIN2270
- Jeweled bearing
- Carbide contact point
- Two measuring directions
- Anti magnetic body
- Supplied with two clamps: diameter Ø4mm and Ø8mm
- Optional accessory: styli

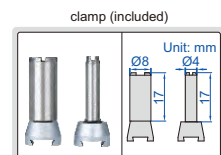

2383-08A

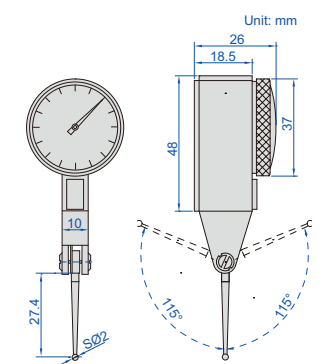

Code	Range	Graduation	Accuracy	Hysteresis	Dial reading
2383-08A*	0.8mm	0.01mm	13µm	3µm	0-40-0

\*Supplied with manufacturer inspection certificate

### VERTICAL TYPE DIAL TEST INDICATOR

**JEWELLED BEARING**

**INSPECTION CERTIFICATE**

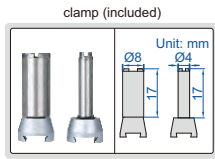

2398-08

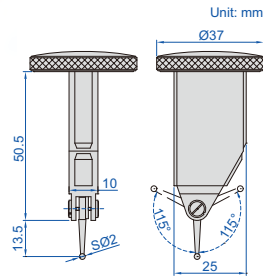

- Meet DIN2270
- Jeweled bearing
- Carbide contact point
- Two measuring directions
- Anti magnetic body
- Supplied with two clamps: diameter Ø4mm and Ø8mm
- Optional accessory: styli

Code	Range	Graduation	Accuracy	Hysteresis	Dial reading
2398-08*	0.8mm	0.01mm	13µm	3µm	0-40-0

\*Supplied with manufacturer inspection certificate

### TILTED FACE TYPE DIAL TEST INDICATOR

**JEWELLED BEARING**

**INSPECTION CERTIFICATE**



2399-08

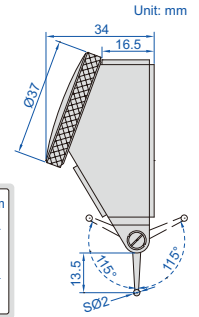
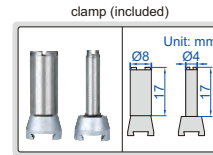

- Meet DIN2270
- Jeweled bearing
- Carbide contact point
- Two measuring directions
- Anti magnetic body
- Supplied with two clamps: diameter Ø4mm and Ø8mm
- Optional accessory: styli

Code	Range	Graduation	Accuracy	Hysteresis	Dial reading
2399-08*	0.8mm	0.01mm	13µm	3µm	0-40-0

\*Supplied with manufacturer inspection certificate

### LARGE RANGE DIAL TEST INDICATOR

**JEWELLED BEARING**

**INSPECTION CERTIFICATE**



2386-16A

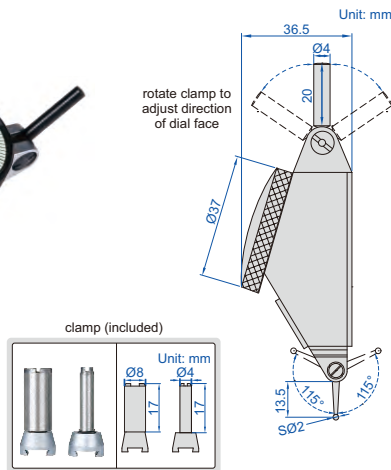

- Jeweled bearing
- Carbide contact point
- Two measuring directions
- Anti magnetic body
- Supplied with two clamps: diameter Ø4mm and Ø8mm
- Optional accessory: styli

Code	Range	Graduation	Accuracy	Hysteresis	Dial reading
2386-16A*	1.6mm	0.01mm	25µm	8µm	0-40-0

\*Supplied with manufacturer inspection certificate

### LARGE RANGE VERTICAL TYPE DIAL TEST INDICATOR

**JEWELLED BEARING**

**INSPECTION CERTIFICATE**



2480-16

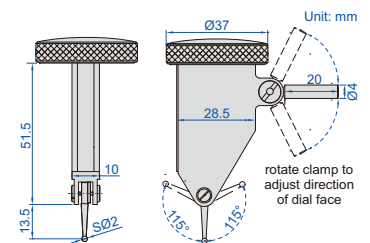
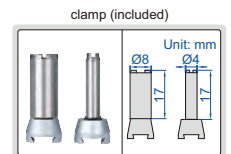

- Dial Reading: 0-40-0
- Jeweled bearing
- Carbide contact point
- Two measuring directions
- Anti magnetic body
- Supplied with two clamps: diameter Ø4mm and Ø8mm
- Optional accessory: styli

Code	Range	Graduation	Accuracy	Hysteresis
2480-16*	1.6mm	0.01mm	18µm	3µm

\*Supplied with manufacturer inspection certificate

### CLAMPS FOR DIAL TEST INDICATORS

Code	ØD
6298-1	Ø4mm
6298-2	Ø8mm



6298-1



6298-2

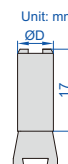

### STYLI FOR DIAL TEST INDICATORS

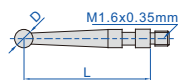

6284-3

Code	For dial test indicator	Material of contact point	(mm)	
			L	D
6284-1	2380-08	steel	13.5	SØ1
6284-3	2398-08	carbide	13.5	SØ2
6284-4	2381-08	ruby	13.5	SØ2
6284-8	2399-08	carbide	13.5	SØ3
6284-21	2380-02	steel	12.5	SØ1
6284-22	2381-02	carbide	12.5	SØ2

## DIGITAL INDICATORS (STANDARD TYPE)

POPULAR MODEL

DATA OUTPUT

INSPECTION CERTIFICATE

- Button function: on/off, inch/mm, zero, data preset, change measuring direction, absolute/incremental measurement
- Switchable high/low frequency measurement mode, high frequency mode is suitable for high speed moving of spindle and has large power consumption, low power consumption in low frequency mode
- Keep preset data in memory after restart
- CR2032 battery, automatic power off (time is adjustable), data output
- Optional accessory: data output cable (code 7315-50M need receiver, 7302-40M, 7305-40M), backs, contact points



2112-10F

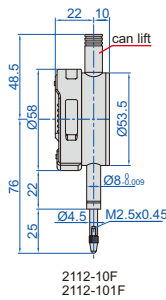

2112-10F  
2112-101F



2112-251F

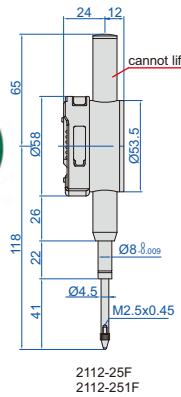

2112-25F  
2112-251F



2112-501F

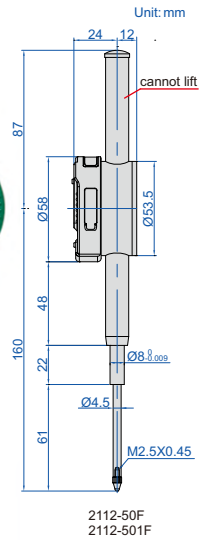

2112-50F  
2112-501F

spindle lift knob is included



Resolution 0.01mm/0.0005"

Code	Range	Accuracy	Hysteresis	Maximum measuring force	Remark
2112-10F*	12.7mm/0.5"	20µm	10µm	1.5N	flat back
2112-25F*	25.4mm/1"	20µm	10µm	2.2N	flat back
2112-50F*	50.8mm/2"	30µm	10µm	2.5N	flat back
2112-10*	12.7mm/0.5"	20µm	10µm	1.5N	lug back
2112-25*	25.4mm/1"	20µm	10µm	2.2N	lug back
2112-50*	50.8mm/2"	30µm	10µm	2.5N	lug back

\*Supplied with manufacturer inspection certificate

Resolution 0.001mm/0.00005"

Code	Range	Accuracy	Hysteresis	Maximum measuring force	Remark
2112-101F*	12.7mm/0.5"	5µm	2µm	1.5N	flat back
2112-251F*	25.4mm/1"	5µm	3µm	2.2N	flat back
2112-501F*	50.8mm/2"	6µm	3µm	2.5N	flat back

## DIGITAL INDICATORS (ADVANCED TYPE)

DATA OUTPUT

INSPECTION CERTIFICATE



display can be rotated by 320°

spindle lift knob is included



2103-10F

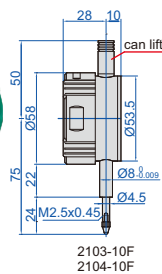

2103-10F  
2104-10F



2103-25F

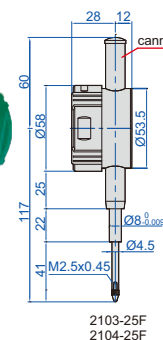

2103-25F  
2104-25F



2103-50F

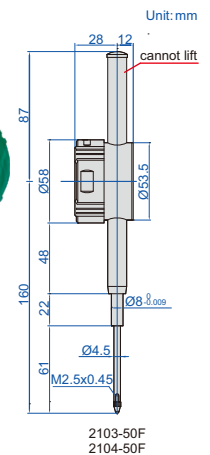

2103-50F  
2104-50F

- Reading in digital and analog
- Display can be rotated by 320°
- Button function: tolerance Go and No-Go display, data preset, measuring direction change, max./min./TIR measurement, inch/metric conversion, absolute/incremental measurement
- Keep preset data and tolerance data in memory after restart
- CR2032 battery, automatic power off (time is adjustable)
- Data output
- Optional accessory: data output cable (code 7315-50M need receiver, 7302-40M, 7305-40M), backs, contact points

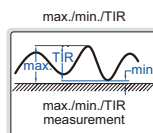

max./min./TIR



analog pointer



alarm when over tolerance

Resolution 0.001mm/0.00005"

Code	Range	Accuracy	Hysteresis	Maximum measuring force	Remark
2103-10F*	12.7mm/0.5"	5µm	2µm	1.5N	flat back
2103-25F*	25.4mm/1"	5µm	3µm	2.2N	flat back
2103-50F*	50.8mm/2"	6µm	3µm	2.5N	flat back

Resolution 0.01mm/0.0005"

Code	Range	Accuracy	Hysteresis	Maximum measuring force	Remark
2104-10F*	12.7mm/0.5"	20µm	10µm	1.5N	flat back
2104-25F*	25.4mm/1"	20µm	10µm	2.2N	flat back
2104-50F*	50.8mm/2"	30µm	10µm	2.5N	flat back

\*Supplied with manufacturer inspection certificate

DIGITAL INDICATORS (WITH TRANSMISSION BUTTON AND SIGNAL LIGHT)



DATA OUTPUT

INSPECTION CERTIFICATE

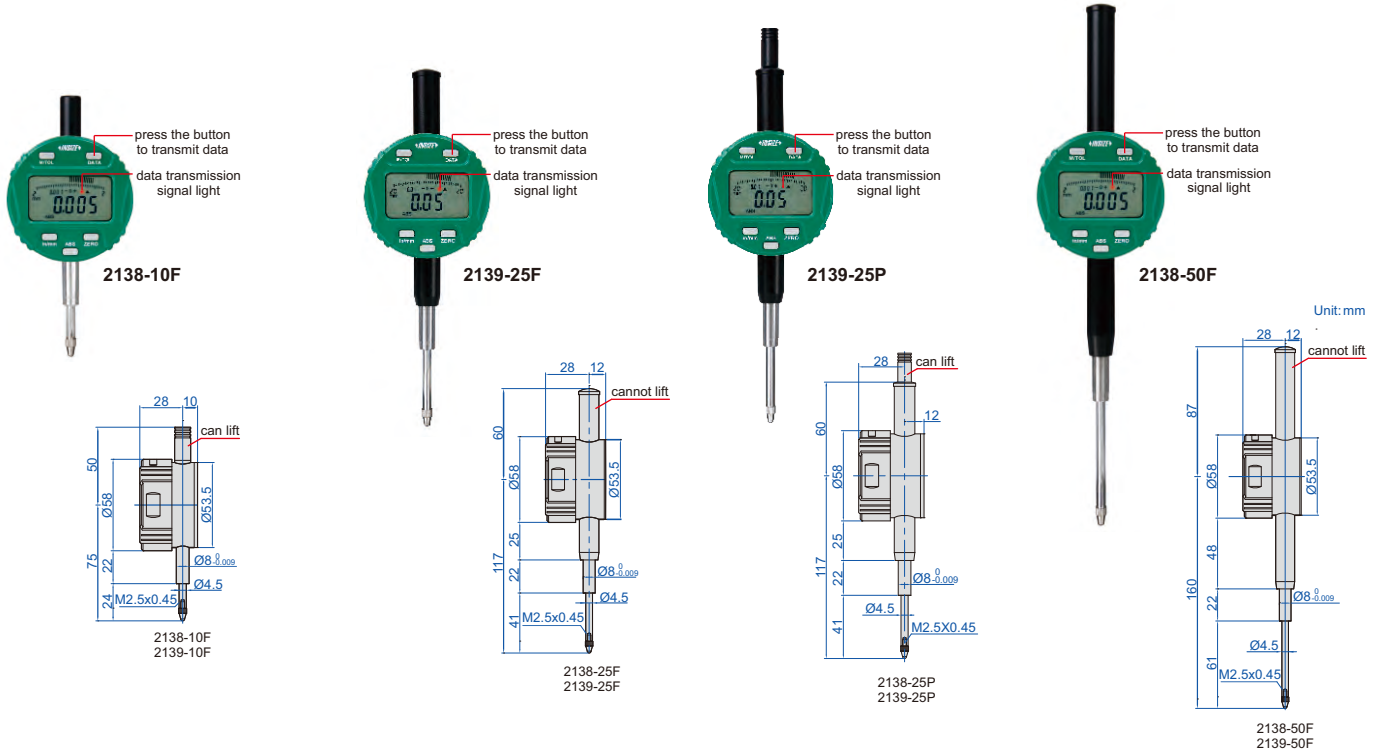

- Reading in digital and analog
- Display can be rotated by 320°
- Button function: on/off, zero, tolerance Go and No-Go display, data preset, measuring direction change, max./min./TIR measurement, inch/metric conversion, absolute/incremental measurement, data output
- Keep preset data and tolerance data in memory after restart
- CR2032 battery, automatic power off (time is adjustable)
- Data output
- Optional accessory: data output cable (code 7315-51 need receiver, 7302-40M, 7305-40M), backs, contact points

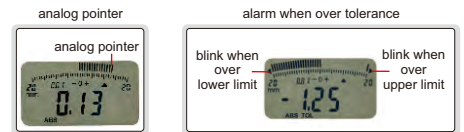

Resolution 0.001mm/0.00005"

Code	Range	Accuracy	Hysteresis	Maximum measuring force	Remark
2138-10F*	12.7mm/0.5"	5µm	2µm	1.5N	flat back
2138-25F*	25.4mm/1"	5µm	3µm	2.2N	flat back
2138-50F*	50.8mm/2"	6µm	3µm	2.5N	flat back
2138-25P*	25.4mm/1"	5µm	3µm	2.2N	flat back, with lift cap
2138-50P*	50.8mm/2"	6µm	3µm	2.5N	flat back, with lift cap

Resolution 0.01mm/0.0005"

Code	Range	Accuracy	Hysteresis	Maximum measuring force	Remark
2139-10F*	12.7mm/0.5"	20µm	10µm	1.5N	flat back
2139-25F*	25.4mm/1"	20µm	10µm	2.2N	flat back
2139-50F*	50.8mm/2"	30µm	10µm	2.5N	flat back
2139-25P*	25.4mm/1"	20µm	10µm	2.2N	flat back, with lift cap
2139-50P*	50.8mm/2"	30µm	10µm	2.5N	flat back, with lift cap

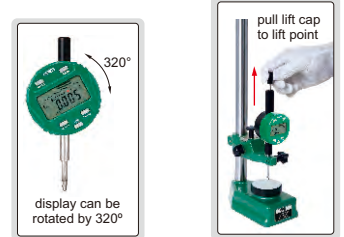

\*Supplied with manufacturer inspection certificate

## WATERPROOF DIGITAL INDICATORS

WATERPROOF

DATA OUTPUT

INSPECTION CERTIFICATE

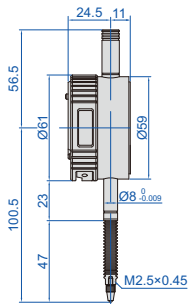

2115-10F  
2115-101F



2115-10F

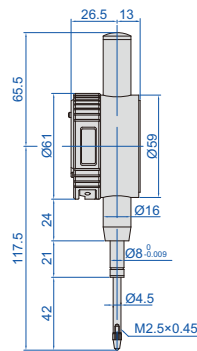

2115-25F  
2115-251F



2115-25F

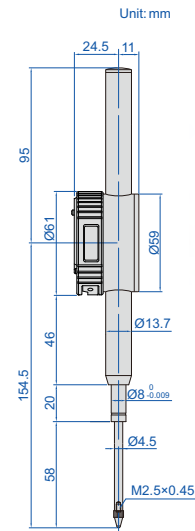

2115-50F  
2115-501F



2115-50F

spindle lift knob is included (except 2115-101F, 2115-10F)



max./min./TIR

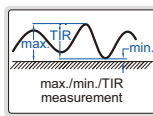

### Resolution 0.001mm/0.00005"

Code	Range	Dust/waterproof	Accuracy	Hysteresis	Remark
2115-101F*	12.7mm/0.5"	IP65	5µm	2µm	flat back
2115-251F*	25.4mm/1"	IP54	5µm	3µm	flat back
2115-501F*	50.8mm/2"	IP54	6µm	3µm	flat back

### Resolution 0.01mm/0.0005"

Code	Range	Dust/waterproof	Accuracy	Hysteresis	Remark
2115-10F*	12.7mm/0.5"	IP65	20µm	10µm	flat back
2115-25F*	25.4mm/1"	IP54	20µm	10µm	flat back
2115-50F*	50.8mm/2"	IP54	30µm	10µm	flat back

\*Supplied with manufacturer inspection certificate

- Dust/waterproof
- Button function: on/off, zero, mm/inch, data preset, tolerance, change measuring direction, max./min./TIR measurement, absolute/incremental measurement
- Keep preset data and tolerance data in memory after restart
- CR2032 battery, automatic power off
- Data output
- Optional accessory: data output cable (code 7315-50M need receiver, 7302-40M, 7305-40M), backs, contact points

alarm when over tolerance



## DIGITAL INDICATOR FOR BORE GAGES (WITH TRANSMISSION BUTTON AND SIGNAL LIGHT)

INSPECTION CERTIFICATE

DATA OUTPUT

THE ORIGINAL DATA REMAINS AFTER POWER OFF

- Specially designed for bore gages
- The minimum value tracking function can find the diameter automatically
- Read the diameter directly, after inputting the size of setting ring
- Reading in digital and analog
- Display can be rotated by 320°
- Button function: on/off, minimum value tracking, calibration, data preset, inch/metric conversion
- Data remains after power off, no need to recalibrate after power on
- CR2032 battery
- Automatic power off (time is adjustable)
- Data output, with flat back
- Optional accessory: data output cable (code 7315-51 need receiver, 7302-40M, 7305-40M), backs, contact points, spindle lift knob

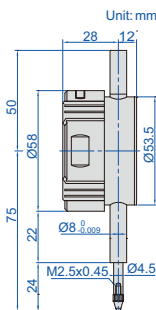

2108-10F

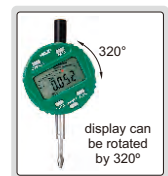

Code	Range	Resolution	Accuracy	Hysteresis
2108-10F*	12.7mm/0.5"	0.002mm/0.0001" (can switch to: 0.01mm/0.0005")	20µm	10µm

\*Supplied with manufacturer inspection certificate

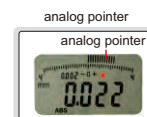

read the diameter directly, after inputting the size of setting ring.

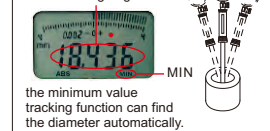

## COMPACT DIGITAL INDICATOR



DATA OUTPUT

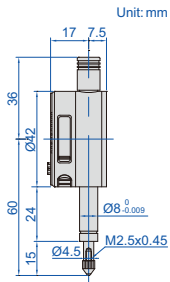

2114-5F

- Button function:
  - in/mm: short press for inch/metric conversion
  - long press to change measuring direction
  - ABS: short press for absolute/incremental measurement
  - long press to preset data
  - 0/O/N: short press to turn on when power is off
  - short press to set zero when power is on
  - long press to turn off
- Keep preset data in memory after restart
- CR1632 battery, automatic power off
- Data output, with flat back
- Optional accessory: data output cable (code 7315-50M need receiver, 7302-40M, 7305-40M), contact points

Code	Range	Resolution	Accuracy	Hysteresis
2114-5F *	5mm/0.2"	0.01mm/0.0005"	20µm	10µm

\*Supplied with manufacturer inspection certificate

## BACK PLUNGER TYPE DIGITAL INDICATOR



DATA OUTPUT

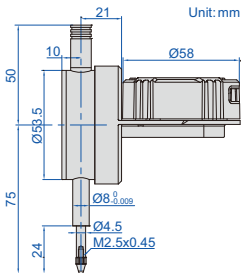

2118-10

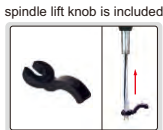
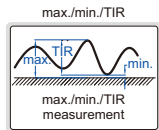
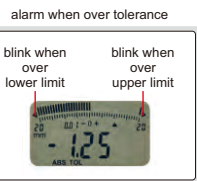

- Display can rotate 320°, and display direction is changeable
- Reading in digital and analog
- Button function: tolerance Go and No-Go display, data preset, measuring direction change, max./min./TIR measurement, inch/metric conversion, absolute/incremental measurement
- Keep preset data and tolerance data in memory after restart
- CR2032 battery, automatic power off (time is adjustable)
- Data output, with flat back
- Optional accessory: data output cable (code 7315-50M need receiver, 7302-40M, 7305-40M), backs, contact points

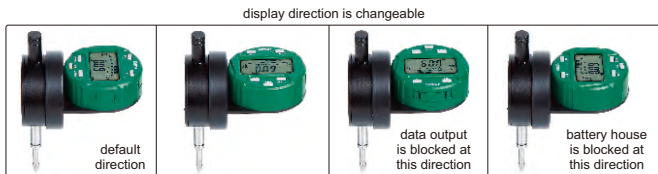

remark: to change above direction, 4 fixing screws on the back of display need to be removed first

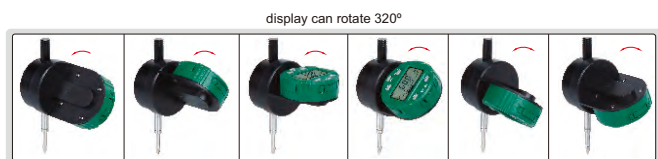

Code	Range	Resolution	Accuracy	Hysteresis
2118-10*	12.7mm/0.5"	0.01mm/0.0005"	20µm	10µm

\*Supplied with manufacturer inspection certificate

## LARGE STROKE DIGITAL INDICATORS

DATA OUTPUT

spindle lift knob is included

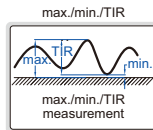

2117-100

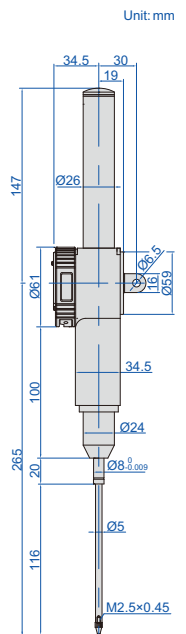

- Button function: on/off, zero, mm/inch, data preset, tolerance, change measuring direction, max./min./TIR measurement, absolute/incremental measurement
- Keep preset data and tolerance data in memory after restart
- CR2032 battery, automatic power off
- Maximum measuring force: 3.2N
- Data output
- Optional accessory: data output cable (code 7315-50M need receiver, 7302-40M, 7305-40M), backs, contact points

Resolution 0.01mm/0.0005"

Code	Range	Accuracy	Hysteresis	Remark
2117-100	100mm/4"	30µm	10µm	lug back

Resolution 0.001mm/0.00005"

Code	Range	Accuracy	Hysteresis	Remark
2117-1001	100mm/4"	9µm	3µm	lug back

## INDUCTIVE DIGITAL COMPARATOR (HIGH ACCURACY)

**IP54**  
WATERPROOF

**DATA**  
OUTPUT

**ATTENTION: RECHARGEABLE BATTERY,  
FOR 12 HOURS CONTINUOUS WORKING**

wireless receiver (optional)



max./min./TIR

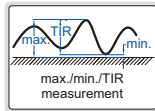

printer (optional)



- Built-in wireless transmission
- IP54 dust/waterproof
- Reading in digital and analog
- Display can be rotated by 320°
- Can store 10 set parameters, and the parameter can be searched and recalled
- 999 groups value can be stored
- Touch sensor: use the sensor to transmit data, avoiding press the button to cause deformation of the dial indicator stand and affect the zero position
- Button function: on/off, zero, data hold, measuring direction change, inch/metric conversion, data preset, absolute/incremental measurement, max./min./TIR measurement, tolerance Go and No-Go display, data output, analog pointer resolution and range change, print data
- Power: rechargeable battery, for 12 hours continuous working
- Ruby probe
- Data output
- Optional accessory: wireless receiver (code **2149-RE**, transmission distance is 2 meters), printer (code **ISF-DF-PRINTER**)



2149-2

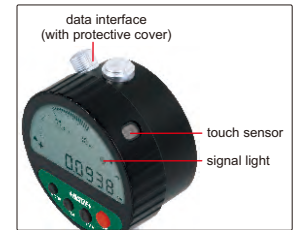
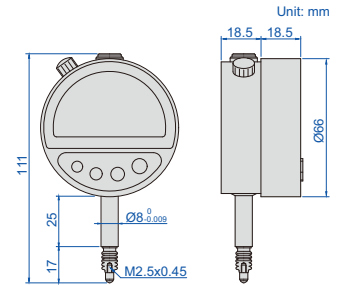

Code	Range	Resolution	Accuracy	Hysteresis	Repeatability	Measuring force
2149-2	2mm/0.08"	0.1µm/0.000005"	0.5µm	0.2µm	0.3µm	0.8-1N

## HIGH PRECISION DIGITAL INDICATORS



**ABSOLUTE ENCODER, THE ORIGINAL  
DATA REMAINS AFTER POWER OFF**

**ATTENTION: RECHARGEABLE BATTERY,  
FOR 24 HOURS CONTINUOUS WORKING**

**DATA**  
OUTPUT

**LINEAR BALL BEARINGS  
FOR TEN MILLION TIMES USE**

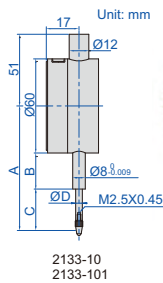
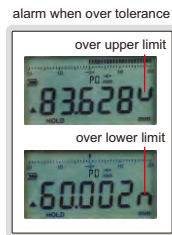
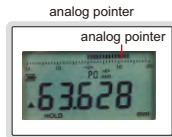

2133-10

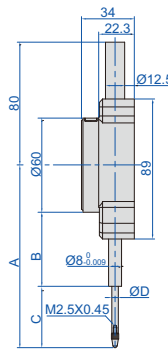

2133-25

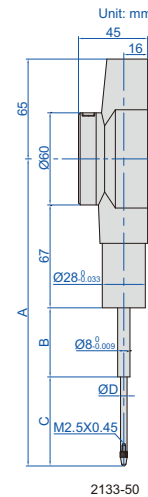

2133-50

- Linear ball bearings for ten million times use
- Absolute encoder, the original data remains after power off
- Reading in digital and analog
- Data output
- With flat back
- Button function: data output, tolerance, data preset, data hold, measuring direction change, max./min./TIR, power off time, on/off, mm/inch, adjust resolution
- Power: rechargeable battery, for 24 hours continuous working
- Optional accessory: contact points, wireless transmitter, code **7315-60** need receiver, data output cable (keyboard format), code **7302-60**, data output cable (serial port format), code **7305-G60** (cable length 3m, optional cable length maximum 15m; RS232 protocol, optional RS485 protocol)

### Standard precision

Carbide probe  
Adjustable resolution: 0.0005mm/0.00002"  
0.001mm/0.00005"  
0.01mm/0.0005"

Code	Range	Accuracy	Hysteresis	A	B	C	ØD
2133-10*	12.7mm/0.5"	3µm	1.5µm	75.4	20.6	24.8	5
2133-25*	25.4mm/1"	3µm	1.5µm	109.5	38.5	41	5
2133-50*	50.8mm/2"	3µm	1.5µm	201	32	72	4.5

spindle lift knob is included



max./min./TIR

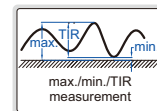

### High precision

Ruby probe  
Adjustable resolution: 0.0002mm/0.00001"  
0.001mm/0.00005"  
0.01mm/0.0005"

Code	Range	Accuracy	Hysteresis	A	B	C	ØD
2133-101*	12.7mm/0.5"	1.5µm	1µm	77.4	26	21.4	4
2133-251*	25.4mm/1"	1.8µm	1µm	116.1	42.5	44	4

\*Supplied with manufacturer inspection certificate

## HIGH PRECISION DIGITAL INDICATORS

**ATTENTION: RECHARGEABLE BATTERY, FOR 24 HOURS CONTINUOUS WORKING**

**ABSOLUTE ENCODER, THE ORIGINAL DATA REMAINS AFTER POWER OFF**

**LINEAR BALL BEARINGS FOR TEN MILLION TIMES USE**

**DATA OUTPUT**

**Ø28MM STEM SUITABLE FOR REINFORCED CLAMPING**

### With data interface

Optional accessory:  
wireless transmitter, code **7315-60** need receiver  
data output cable (keyboard format), code **7302-60**  
data output cable (serial port format), code **7305-G60**  
(cable length 3m, optional cable length maximum 15m;  
RS232 protocol, optional RS485 protocol)

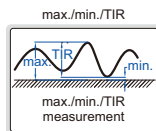

wireless receiver  
**2134-R1, 2134-R2 (optional)**

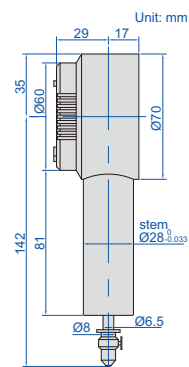

alarm when over tolerance

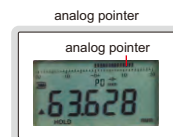
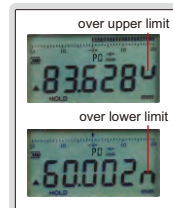

**2140-6**

- Linear ball bearings for ten million times use
- Ø28mm stem suitable for reinforced clamping
- Absolute encoder, the original data remains after power off
- Adjustable resolution: 0.002mm/0.00001"  
0.001mm/0.00005"  
0.01mm/0.0005"
- Reading in digital and analog
- Button function: data output, tolerance, data preset, data hold, measuring direction change, max./min./TIR, power off time, on/off, mm/inch, adjust resolution
- Power: rechargeable battery, for 24 hours continuous working
- Ruby probe

Code	Range	Accuracy	Hysteresis	Remark
<b>2140-6</b>	0-6mm/0-0.24"	1.6µm	0.8µm	flat back

### Built-in wireless

Optional accessory:  
wireless receiver (keyboard format, connect up to 15 digital indicators), code **2134-R1**  
wireless receiver (serial port format, connect up to 15 digital indicators), code **2134-R2**

Code	Range	Accuracy	Hysteresis	Remark
<b>2140-6WL*</b>	0-6mm/0-0.24"	1.6µm	0.8µm	flat back

\*Continuous data collection can be customized (press "DATA" button to start continuous collection, press again to stop; collection frequency can be customized, the fastest data collection is 10 pcs per second)

## PRECISION DIAL INDICATORS

**INSPECTION CERTIFICATE**

**JEWELLED BEARING**



**2313-1A**

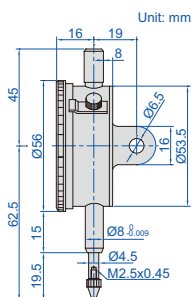

- Graduation: 0.001mm
- Dial reading: 0-100-0
- Jeweled bearing
- Supplied with limit pointers and bezel clamp
- Optional accessory: backs, contact points

Code	Range	Accuracy	Hysteresis	Range/rev	Remark
<b>2313-1FA*</b>	1mm	5µm	2µm	0.2mm	flat back
<b>2313-2FA*</b>	2mm	6µm	2.5µm	0.2mm	flat back
<b>2313-1A*</b>	1mm	5µm	2µm	0.2mm	lug back

\*Supplied with manufacturer inspection certificate

## COMPACT DIAL INDICATORS

**INSPECTION CERTIFICATE**

**JEWELLED BEARING**



**2311-5**

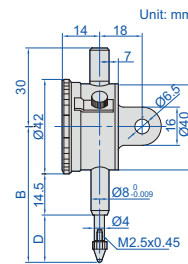

- Range/rev: 0.5mm
- Dial reading: 0-50
- Meet DIN878
- Jeweled bearing
- Supplied with limit pointers and bezel clamp
- Optional accessory: backs, contact points

Code	Range	Graduation	Accuracy	Hysteresis	Remark	B	D
<b>2311-3F*</b>	3mm	0.01mm	12µm	3µm	flat back	46	10.5
<b>2311-5F*</b>	5mm	0.01mm	14µm	3µm	flat back	48	12.5
<b>2311-3*</b>	3mm	0.01mm	12µm	3µm	lug back	46	10.5
<b>2311-5*</b>	5mm	0.01mm	14µm	3µm	lug back	48	12.5

\*Supplied with manufacturer inspection certificate

## DIAL INDICATORS (STANDARD TYPE)

- Graduation: 0.01mm
- Dial reading: 0-100
- Meet DIN878
- Jeweled bearing
- Supplied with limit pointers and bezel clamp
- Optional accessory: backs, contact points

Code	Range	Accuracy	Hysteresis	Range/rev	Remark
<b>2308-3FA*</b>	3mm	12µm	3µm	1mm	flat back
<b>2308-5FA*</b>	5mm	14µm	3µm	1mm	flat back
<b>2308-10FA*</b>	10mm	17µm	3µm	1mm	flat back
<b>2308-3A*</b>	3mm	12µm	3µm	1mm	lug back
<b>2308-5A*</b>	5mm	14µm	3µm	1mm	lug back
<b>2308-10A*</b>	10mm	17µm	3µm	1mm	lug back

\*Supplied with manufacturer inspection certificate

**INSPECTION CERTIFICATE**

**JEWELLED BEARING**



**2308-10A**

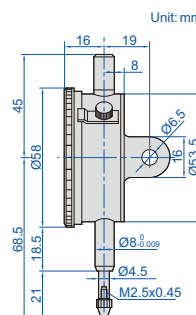



## DIAL INDICATORS (BASIC TYPE)

POPULAR MODEL



2301-10

INSPECTION CERTIFICATE

JEWELLED BEARING

- Graduation: 0.01mm
- Dial reading: 0-100
- Meet DIN878
- Jeweled bearing
- Supplied with limit hands and bezel clamp
- Packed in carton box
- Optional accessory: backs, contact points

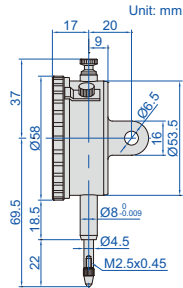

Code	Range	Accuracy	Hysteresis	Range/rev	Remark
2301-10F*	10mm	17µm	3µm	1mm	flat back
2301-10*	10mm	17µm	3µm	1mm	lug back with spare flat back

\*Supplied with manufacturer inspection certificate

## SHOCKPROOF DIAL INDICATORS

INSPECTION CERTIFICATE

JEWELLED BEARING

SHOCK PROOF



2314-10A

- Graduation: 0.01mm
- Dial reading: 0-100
- Meet DIN878
- Shockproof
- Jeweled bearing
- Supplied with limit pointers and bezel clamp
- Optional accessory: backs, contact points

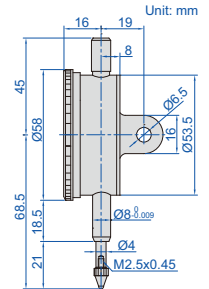

Code	Range	Accuracy	Hysteresis	Range/rev	Remark
2314-10FA*	10mm	17µm	3µm	1mm	flat back
2314-10A*	10mm	17µm	3µm	1mm	lug back

\*Supplied with manufacturer inspection certificate

## WATERPROOF DIAL INDICATORS

INSPECTION CERTIFICATE

IP54 WATERPROOF



2324-10A

- Hysteresis: 3µm
- Dial reading: 0-100
- Meet DIN878
- IP54 dust/waterproof
- With limit pointers
- Optional accessory: back, contact points

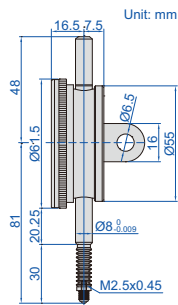

Code	Range	Graduation	Accuracy	Range/rev	Remark
2324-10FA*	10mm	0.01mm	17µm	1mm	flat back
2324-10A*	10mm	0.01mm	17µm	1mm	lug back

\*Supplied with manufacturer inspection certificate

## DIAL INDICATORS (LONG STROKE)

INSPECTION CERTIFICATE



2310-30A

- Graduation: 0.01mm
- Dial reading: 0-100
- Supplied with limit pointers and bezel clamp
- Optional accessory: backs, contact points

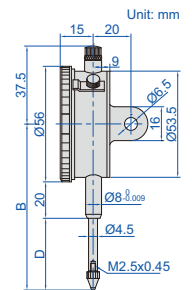

Code	Range	Accuracy	Hysteresis	Range/rev	Remark	B	D
2310-20FA*	20mm	25µm	5µm	1mm	flat back	83	35
2310-30FA*	30mm	35µm	7µm	1mm	flat back	88	40
2310-20A*	20mm	25µm	5µm	1mm	lug back	83	35
2310-30A*	30mm	35µm	7µm	1mm	lug back	88	40

\*Supplied with manufacturer inspection certificate

## DIAL INDICATOR (LONG STROKE, BASIC TYPE)

POPULAR MODEL

INSPECTION CERTIFICATE

- Graduation: 0.01mm
- Dial reading: 0-100
- Supplied with limit pointers and bezel clamp
- Packed in carton box
- Optional accessory: backs, contact points



2302-25F

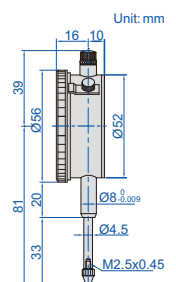

Code	Range	Accuracy	Hysteresis	Range/rev	Remark
2302-25F*	25mm	35µm	7µm	1mm	flat back

\*Supplied with manufacturer inspection certificate

**DOUBLE FACE DIAL INDICATOR**



front

back

2328-10

**JEWELLED BEARING**

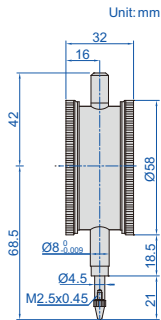

Unit: mm

- Graduation: 0.01mm
- Meet DIN878
- Read from both sides
- Jeweled bearing
- Supplied with limit pointers
- Optional accessory: contact points

Code	Range	Accuracy	Hysteresis	Range/rev	Dial reading
2328-10*	10mm	17µm	3µm	1mm	0-100

\*Supplied with manufacturer inspection certificate

**ONE REVOLUTION DIAL INDICATORS**



**SHOCK PROOF**



2316-05F

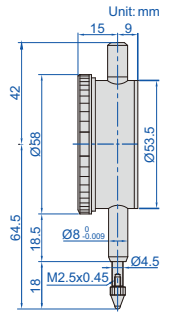

Unit: mm

- Dial indicator stroke: 5mm
- Meet DIN878
- Eliminate the possibility of reading errors due to miscounting
- Shockproof
- With flat back
- Supplied with limit pointers
- Optional accessory: backs, contact points

Code	Range	Graduation	Accuracy	Hysteresis	Dial reading
2316-05F*	0.5mm	0.01mm	9µm	3µm	25-0-25
2316-1F*	1mm	0.01mm	9µm	3µm	50-0-50

\*Supplied with manufacturer inspection certificate

**DIAL INDICATORS (LONG STROKE)**



**JEWELLED BEARING**

**SHOCK PROOF**



stem clamp Ø10mm of 2309-100D



back of type B



2309-50

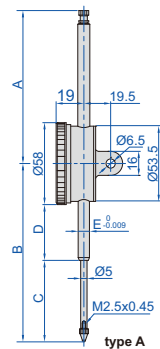

type A

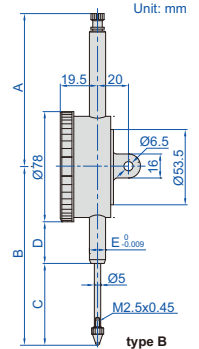

type B

Unit: mm

- Range/rev: 1mm
- Dial reading: 0-100
- Shockproof
- Jeweled bearing
- Supplied with limit pointers
- Optional accessory: backs, contact points

Code	Range	Type	Graduation	Accuracy	Hysteresis	Remark
2309-30F*	30mm	A	0.01mm	35µm	7µm	flat back
2309-50*	50mm	A	0.01mm	40µm	8µm	flat back with spare lug back
2309-50D*	50mm	B	0.01mm	40µm	8µm	flat back with spare lug back
2309-100D	100mm	B	0.01mm	50µm	9µm	flat back with spare lug back

Code	Type	A	B	C	D	E	(mm)
2309-30F	A	37.5	89.5	40.9	19.5	Ø8	
2309-50	A	108.3	126.2	57.7	39.5	Ø8	
2309-50D	B	108.3	126.2	57.7	29.5	Ø8	
2309-100D	B	167.6	207.8	108	60.8	Ø10	

- Note: 1) 2309-100D can only be used vertically  
 2) 2309-100D is supplied with stem clamp Ø10mm for magnetic stands (code 6200-60, 6201-60, 6202-80, 6202-100)  
 3) 2309-30F can not accept optional backs

\*Supplied with manufacturer inspection certificate

**EXTENSION RODS**



6282-2011

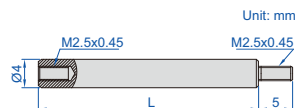

Unit: mm

Code	Material	L
6282-2001	steel	10mm
6282-2002	steel	15mm
6282-2003	steel	20mm
6282-2004	steel	25mm
6282-2005	steel	30mm
6282-2006	steel	35mm
6282-2007	steel	40mm
6282-2008	steel	45mm
6282-2009	steel	50mm

Code	Material	L
6282-2010	steel	55mm
6282-2011	steel	60mm
6282-2012	steel	65mm
6282-2013	steel	70mm
6282-2014	steel	75mm
6282-2015	steel	80mm
6282-2016	steel	90mm
6282-2017	steel	100mm

## CONTACT POINTS

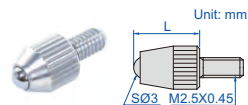

6282-0101

### BALL POINT

Code	Material of measuring face	L (mm)
6282-0101	carbide	7.3
6282-0103	ceramic	7.3
6282-0104	carbide	8.3

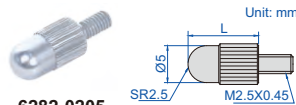

6282-0205

### SHELL TYPE POINT

Code	Material of measuring face	L
6282-0205	steel	15mm
6282-0210	steel	30mm

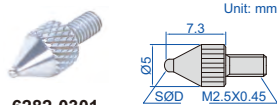

6282-0301

### BALL POINT

Code	Material of measuring face	SØD
6282-0301	steel	1mm
6282-0302	carbide	1.5mm
6282-0303	carbide	1.8mm
6282-0304	carbide	2.5mm
6282-0305	carbide	4mm

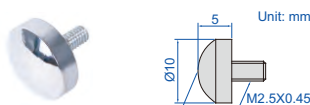

6282-0401

### SPHERICAL POINT

Code	Material of measuring face
6282-0401	steel

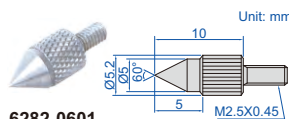

6282-0601

### CONICAL POINT

Code	Material of measuring face
6282-0601	steel

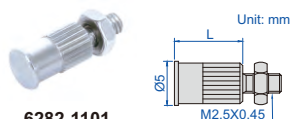

6282-1101

### FLAT POINT

Code	Material of measuring face	L
6282-1101	steel	8mm

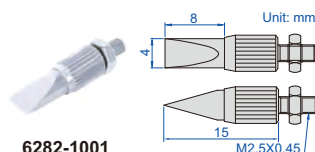

6282-1001

### KNIFE EDGE POINT

Code	Material of measuring face
6282-1001	steel

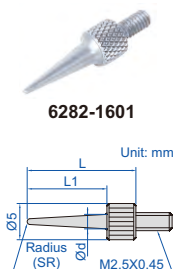

6282-1601

### NEEDLE POINT (mm)

Code	Material of measuring face	L1	L	SR	Ød
6282-1601	steel	11	15	0.4	2
6282-1602	steel	13	17	0.2	2
6282-1603	steel	21	25	0.4	3
6282-1604	steel	31	35	0.4	3



6282-1301

### FLAT POINT

Code	Material of measuring face
6282-1301	carbide

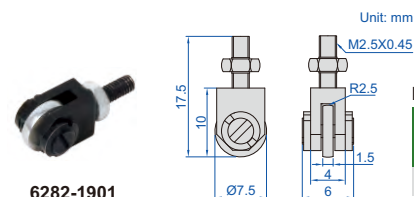

6282-1901

### ROLLER POINT

Code	Material of measuring face
6282-1901	steel



6282-1706

### NEEDLE POINT

Code	Material of measuring face	ØD	L
6282-1705	carbide	1mm	8mm
6282-1706	carbide	1mm	10mm
6282-1707	carbide	1mm	20mm
6282-1708	carbide	1mm	40mm
6282-1712	carbide	1.5mm	20mm
6282-1713	carbide	1.5mm	40mm
6282-1714	carbide	2mm	8mm
6282-1715	carbide	2mm	18mm
6282-1716	carbide	2mm	28mm
6282-1717	carbide	2mm	40mm



6282-1201

### FLAT POINT (mm)

Code	Material of measuring face	ØD	L
6282-1201	steel	10	3
6282-1202	steel	15	4
6282-1203	steel	20	3
6282-1204	steel	25	4
6282-1205	steel	30	4

## SPINDLE LIFT KNOB

Code  
7332

- For dial/digital indicators with spindle diameter Ø4.5mm or Ø5mm



7332



## MAGNETIC BACKS



front

back

7331-M2

(mm)

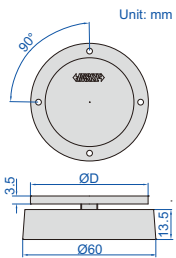

Unit: mm

Code	ØD	For digital/dial indicators
7331-M1	51.5	2103
		2104
		2108
		2109
		2112
		2115
		2116
		2117
		2118
		2138
		2301
		2302
		2308
		2309 (except 2309-30, 2309-30F)
2313		
2314		
2316		
2801		
7331-M2	54	2318

## LUG BACKS



7330-L2

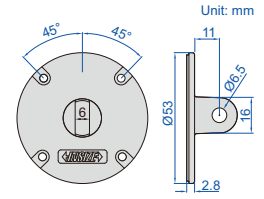

7330-L2 and 7330-L10

Code	For digital/dial indicators
7330-L1	2311
7330-L2	2308
	2309 (except 2309-30, 2309-30F)
	2313
	2314
	2324
	2316
7330-L5	2103
	2104
	2108
	2109
	2112
	2113
2115	
7330-L10	2310

## DIAL INDICATOR TESTER CODE 2396-25A

ATTENTION: NOT SUITABLE FOR INDICATORS WITH GRADUATION 0.001MM

- To calibrate dial indicators, test indicators and dial bore gages
- Dimension: 270x210x205mm
- Weight: 11kg

### Micrometer head

Range	Sampling interval	Accuracy	Hysteresis
0-25mm	0.1mm	4µm (0-25mm), 3µm (0-10mm), 2µm (0-1mm)	1µm

### Force gage

Range	Graduation	Accuracy
0-1.6N	0.05N	±5% (of load capacity)

### Stage

Diameter	Flatness	Roughness
50mm	1µm	0.05µm

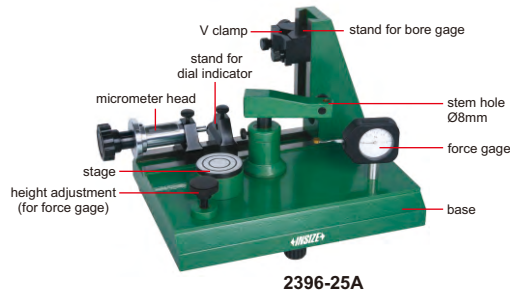

2396-25A



inspect accuracy of dial indicators (range 0-25mm)



inspect accuracy of dial bore gages (range 6-450mm)



inspect accuracy of test indicators

half round gage block  
code 2396-block (optional)

### Half round gage block (optional)

Code	Parallelism
2396-block	1µm



check force of dial indicators



check repeatability of dial indicators



check the effect of lateral force on accuracy of dial indicators (half round gage block is required)

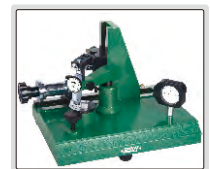

check the effect of lateral force on accuracy of test indicators (half round gage block is required)

## CAPACITIVE LINEAR GAGES

**IP65**  
WATERPROOF



7107-11

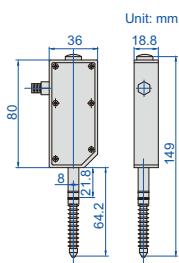

### SPECIFICATION

Code	7107-11	7107-12
Measuring range	12mm/0.47"	12mm/0.47"
Resolution	0.01mm/0.0004"	0.001mm/0.00004"
Accuracy	20µm	5µm
Hysteresis	10µm	2µm
Driving type	spring	
Measuring force	1.5N	
Measuring principle	capacitance type linear encoder	
Voltage	5V	
Sampling frequency	100 times/sec	
Working life	ten million times	
Dust/waterproof	IP65	
Cable length	2m	
Data output	RS232	

- Capacitance type linear encoder
- Shock-proof, water proof, dust proof, suitable for high speed movement, long working life
- Optional: display unit **7106-1A**, multichannel interface box **7107-1** or **7107-2**

## DISPLAY UNIT FOR CAPACITANCE LINEAR GAGES CODE 7106-1A

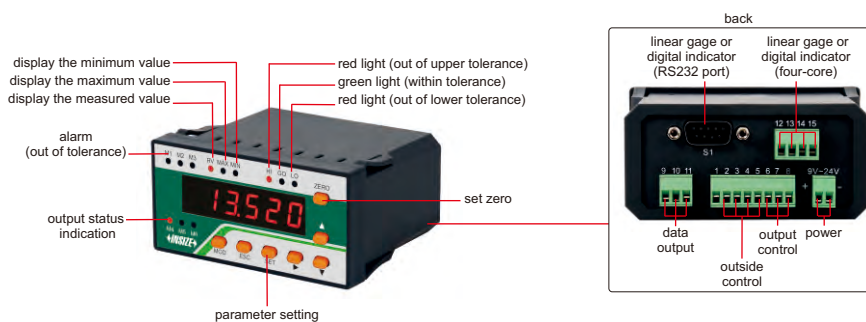

7106-1A

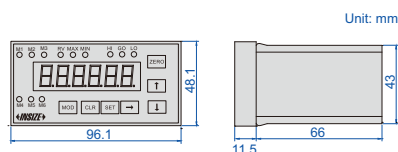

- Can be connected with **7107-11** or **7107-12** linear gage, can also be connected with digital indicator (data cable **7309-C01M** is needed)
- Set tolerance and make judgment (out of upper tolerance, within tolerance, out of lower tolerance), output the judgment to control outside devices, control from outside (set zero, hold reading and collect data)
- Software of display unit (included): in the software, it is possible to set tolerance and show judgment (red when out of tolerance, green when within tolerance), set zero, collect data manually or automatically (time is adjustable), output data to Excel, print report

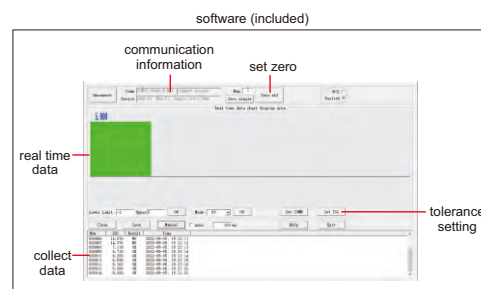

### SPECIFICATION

Display	6 digits
Quantity of linear gage or digital indicator to be connected	1 pc
Tolerance	set tolerance and make judgment with alarm and lights (out of upper tolerance, within tolerance, out of lower tolerance)
Output control	output the tolerance judgment (out of upper tolerance, within tolerance, out of lower tolerance) to control outside devices
Outside control	control the display units from outside (set zero, hold reading and collect data)
Data output	connect to computer software and serial communication
Power supply	DC 9~24V

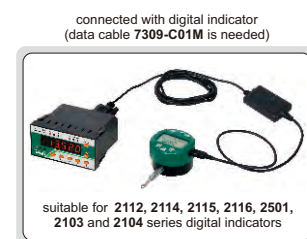

## MULTICHANNEL INTERFACE BOXES FOR CAPACITANCE LINEAR GAGES

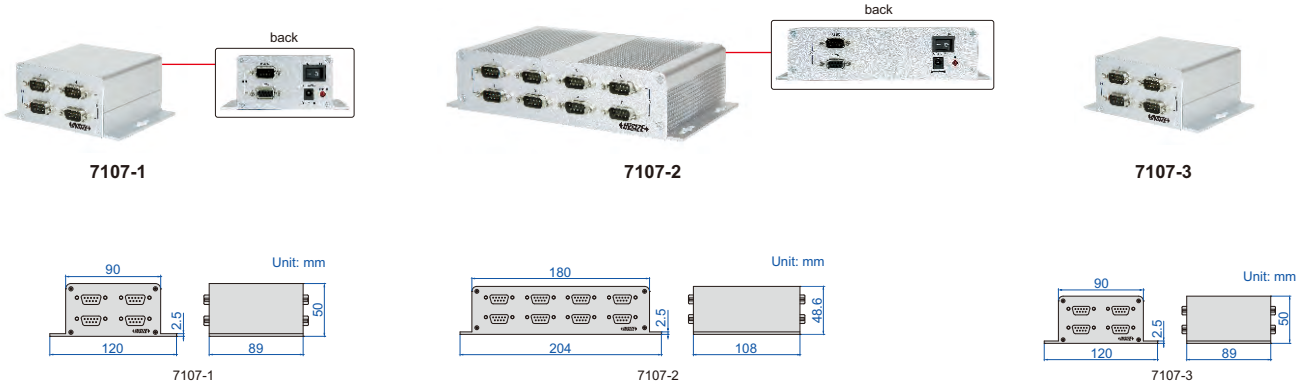

- Can be connected with **7107-11** or **7107-12** linear gages, can also be connected with digital indicators (data cable **7309-C01M** is needed)
- Connection box (code **7107-3**) is needed to connect interface boxes, when two or more interface boxes are used. Maximum 4 interface boxes can be connected.
- Software of interface boxes (included): in the software, it is possible to set tolerance of each channel and show judgment (red when out of tolerance, green when within tolerance), set zero, collect data manually or automatically (time is adjustable), output data to Excel, print report.

### INTERFACE BOX SPECIFICATION

Code	7107-1	7107-2
Quantity of linear gages or digital indicators to be connected	4 pcs	8 pcs
Data output	RS232 and RS485	
Power supply	DC 9~24V	

### CONNECTION BOX (OPTIONAL) SPECIFICATION

Code	7107-3
Quantity of interface boxes to be connected	4 pcs (maximum 4 interface boxes can be connected)
Data output	RS232 and RS485
Power supply	DC 9~24V

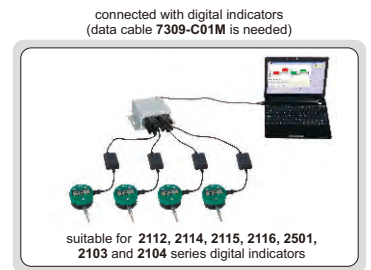
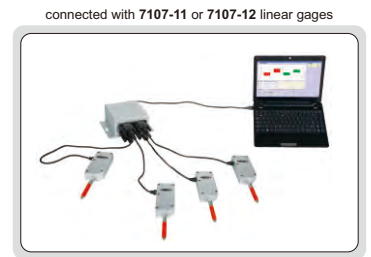
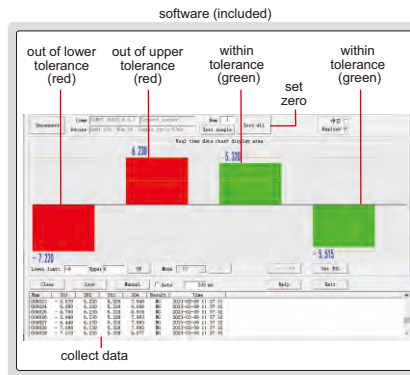

## DIGITAL LINEAR GAGES



**IP43**  
WATERPROOF

**ABSOLUTE ENCODER, THE ORIGINAL DATA REMAINS AFTER POWER OFF**

- Scale type: optical grating
- Absolute encoder, the original data remains after power off
- Digital signal output, amplifier is not required
- Repeatability: 0.5μm
- Measuring force: ≤1.5N
- Dust/waterproof: IP43
- Baud rate: 9600 (can be customized)
- Cable length: 3m (can be customized)



Code	Range	Resolution	Accuracy	Outgoing cable direction	Output signal	Output interface
7130-10	0-12.5mm	0.1μm	1μm	horizontal	RS232, TTL level	
7130-10L	0-12.5mm	0.1μm	1μm	vertical	RS232, TTL level	

### DIAL TEST INDICATOR HOLDER



6291-1

- Can be used with dial test indicators

**Code**  
6291-1

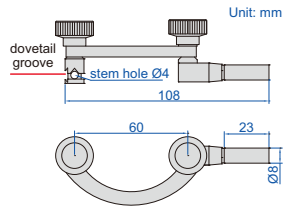

### DIAL TEST INDICATOR UNIVERSAL HOLDER



6297-1



- Set the indicators at the desired attitude to the workpiece

**Code**  
6297-1

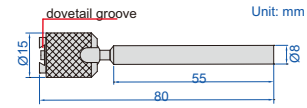

### DIAL TEST INDICATOR HOLDER



6296-1

- Supplied with hex key

**Code**  
6296-1

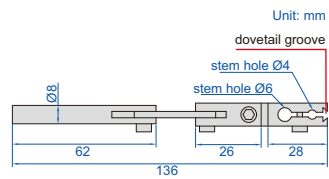

### DIAL TEST INDICATOR HOLDERS



6293-1



6293-2

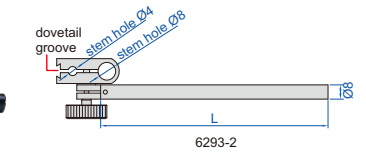
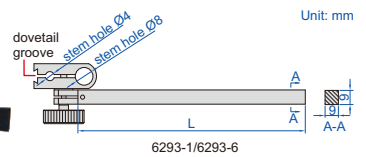

Code	Stem section	Stem length (L)
6293-1	9x9mm	100mm
6293-6	9x9mm	50mm
6293-2	Ø8mm	115mm



### DIAL TEST INDICATOR HOLDER

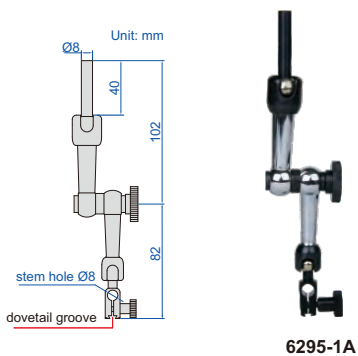

6295-1A

- Can be used with dial test indicators

**Code**  
6295-1A

### DIAL INDICATOR HOLDER

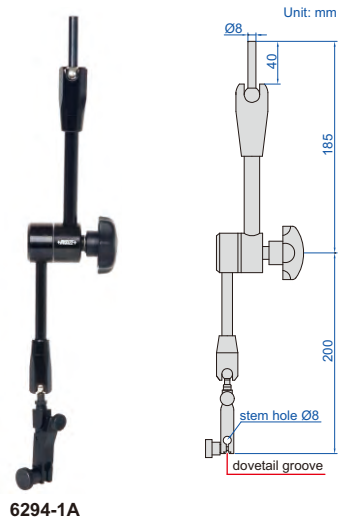

6294-1A

- Can be used with dial test indicators or dial indicators

**Code**  
6294-1A

**HYDRAULIC UNIVERSAL MAGNETIC STANDS**

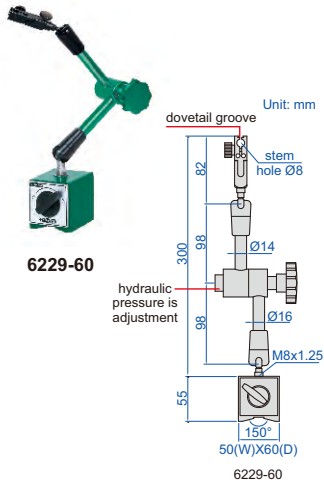

**6229-60**

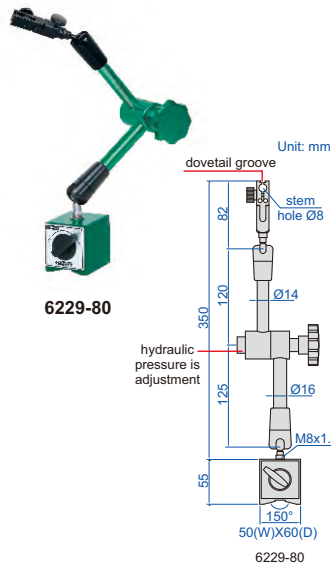

**6229-80**

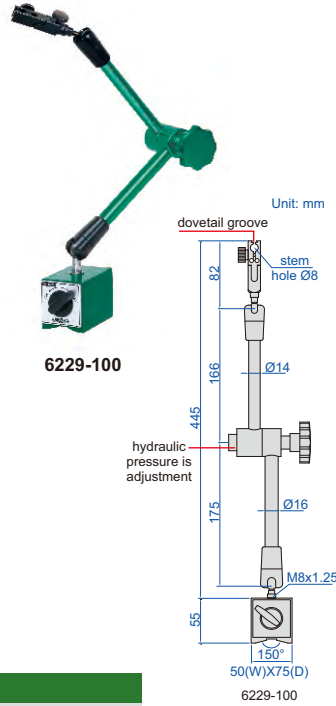

**6229-100**

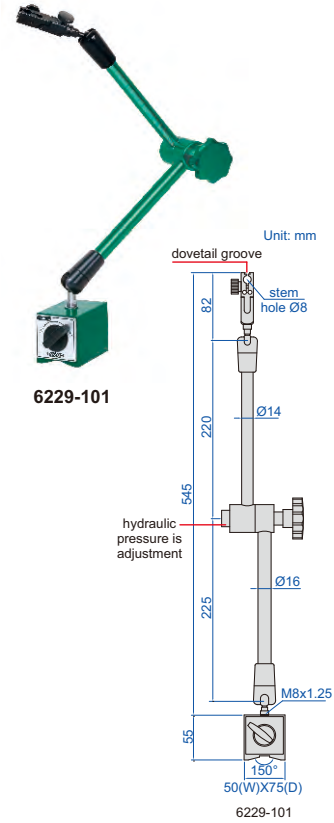

**6229-101**

- Hydraulic pressure is adjustment
- For digital/dial indicators and dial test indicators

Code	Magnetic force	Applicable holding stem	Remark
6229-60	60kgf	Ø8mm	with fine adjustment and dovetail groove
6229-80	80kgf	Ø8mm	with fine adjustment and dovetail groove
6229-100	100kgf	Ø8mm	with fine adjustment and dovetail groove
6229-101	100kgf	Ø8mm	with fine adjustment and dovetail groove

**LARGE LOCKING FORCE MAGNETIC STAND**

- Applicable holding stem: Ø8mm
- For digital/dial indicators and dial test indicators
- With fine adjustment and dovetail groove



**6219-80**

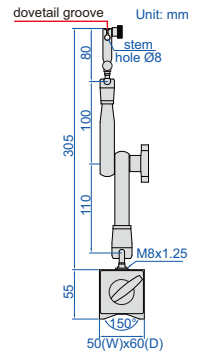

Code	Magnetic force
6219-80	80kgf

**UNIVERSAL MAGNETIC STANDS**

**POPULAR MODEL**

- For digital/dial indicators and dial test indicators
- With fine adjustment and dovetail groove

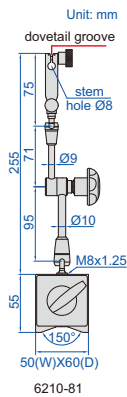

**6210-81**

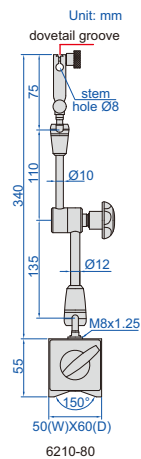

**6210-80**

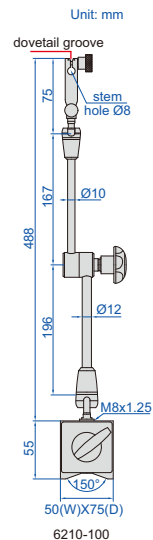

**6210-100**



**6210-100**

Code	Magnetic force	Applicable holding stem
6210-81	80kgf	Ø8mm
6210-80	80kgf	Ø8mm
6210-100	100kgf	Ø8mm



### MAGNETIC STAND WITH TWO FINE ADJUSTMENTS

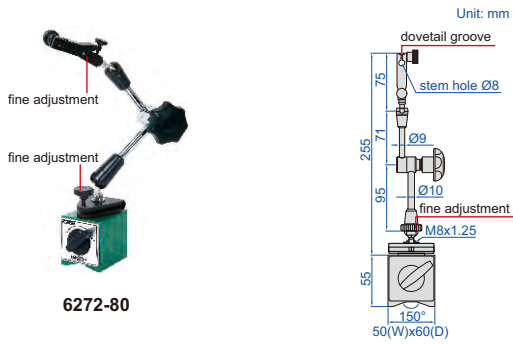

6272-80

- Magnetic force: 80kgf
- With two fine adjustments on the head and on the base
- For digital/dial indicators and dial test indicators
- With two fine adjustments and dovetail groove

Code	Applicable holding stem
6272-80	Ø8mm

### HYDRAULIC MINI MAGNETIC STAND

ATTENTION: FOR DIAL TEST INDICATORS ONLY

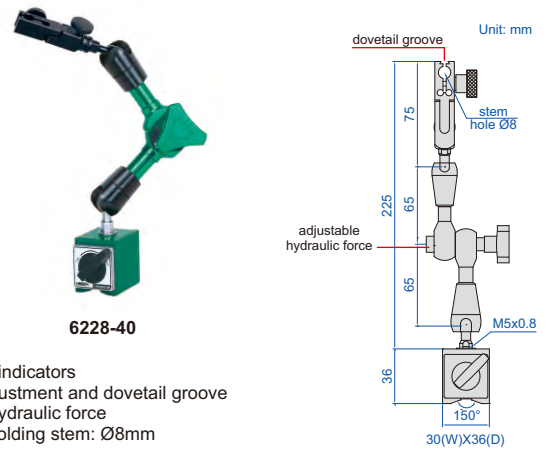

6228-40

- For dial test indicators
- With fine adjustment and dovetail groove
- Adjustable hydraulic force
- Applicable holding stem: Ø8mm

Code	Magnetic force
6228-40	40kgf

### MINI MAGNETIC STAND

ATTENTION: FOR DIAL TEST INDICATORS ONLY

- For dial test indicators
- With fine adjustment and dovetail groove
- Applicable holding stem: Ø8mm

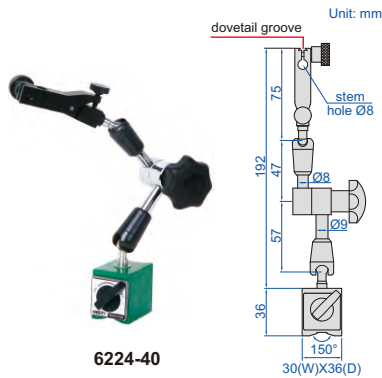

6224-40

Code	Magnetic force
6224-40	40kgf

### MAGNETIC STAND (FOR 0.001MM DIAL AND TEST INDICATORS)

- For 0.001mm and 0.01mm dial and test indicators

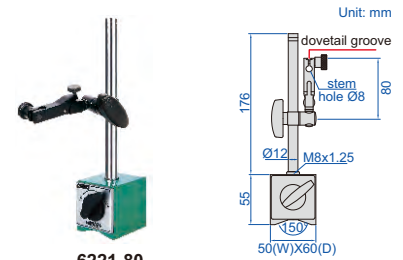

6221-80

Code	Magnetic force	Applicable holding stem	Remark
6221-80	80kgf	Ø8mm	with fine adjustment and dovetail groove

### MAGNETIC STANDS

POPULAR MODEL

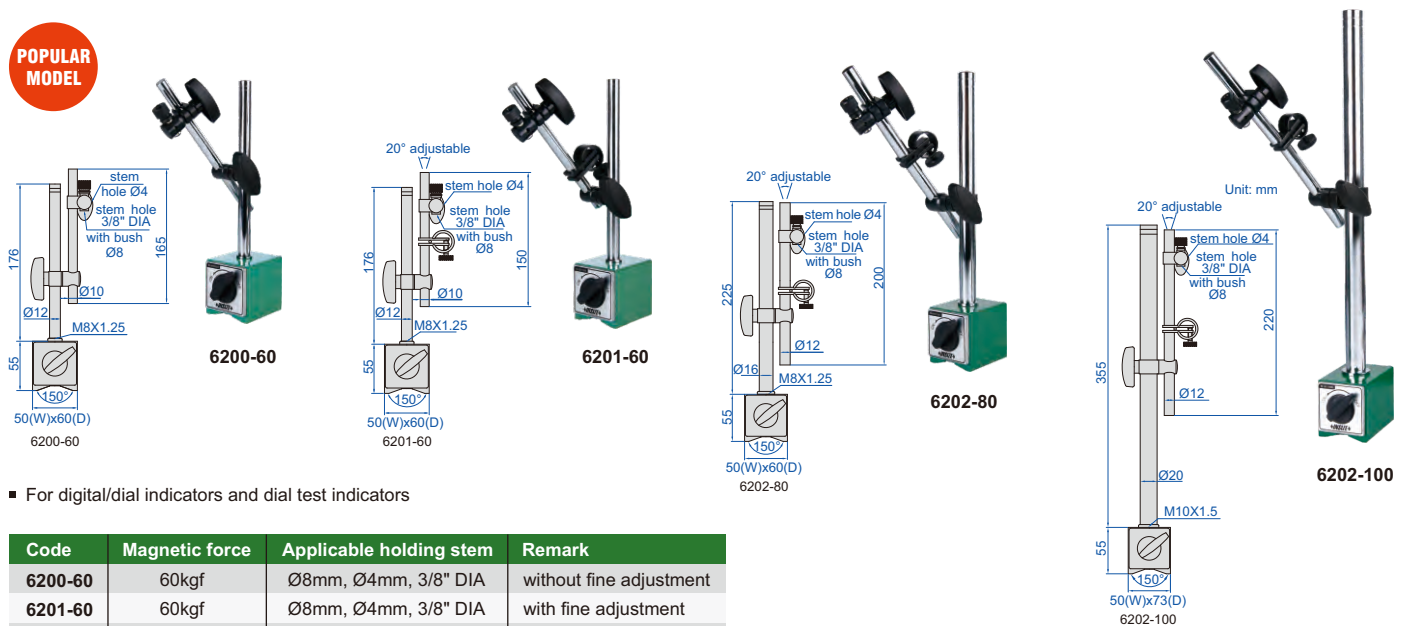

- For digital/dial indicators and dial test indicators

Code	Magnetic force	Applicable holding stem	Remark
6200-60	60kgf	Ø8mm, Ø4mm, 3/8" DIA	without fine adjustment
6201-60	60kgf	Ø8mm, Ø4mm, 3/8" DIA	with fine adjustment
6202-80	80kgf	Ø8mm, Ø4mm, 3/8" DIA	with fine adjustment
6202-100	100kgf	Ø8mm, Ø4mm, 3/8" DIA	with fine adjustment

**MAGNETIC STAND**

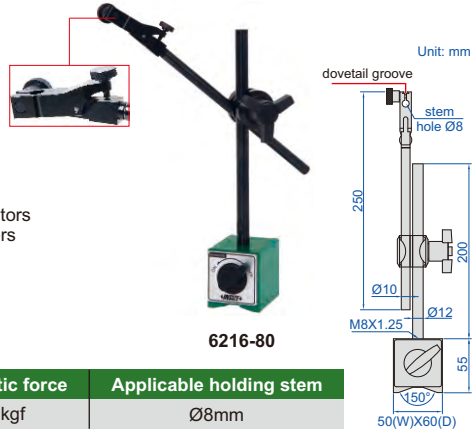

- For digital/dial indicators and dial test indicators
- With fine adjustment and dovetail groove

6216-80

Code	Magnetic force	Applicable holding stem
6216-80	80kgf	Ø8mm

**FLEX ARM MAGNETIC STAND**

**ATTENTION: FOR DIAL TEST INDICATORS ONLY**

- For dial test indicators
- Applicable holding stem: Ø8mm, Ø4mm, 3/8" DIA.

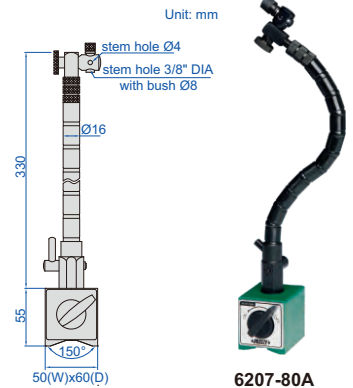

6207-80A

Code	Magnetic force
6207-80A	80kgf

**MINI MAGNETIC STAND**

- For dial test indicators
- With dovetail groove
- Applicable holding stem: Ø6mm, Ø8mm



6211-10

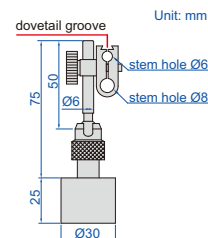

**ATTENTION: FOR DIAL TEST INDICATORS ONLY**

Code	Magnetic force
6211-10	10kgf

**UNIVERSAL STAND**

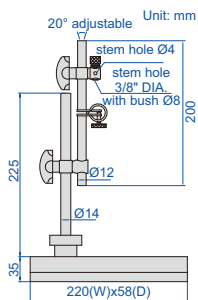

6214-A

- For digital/dial indicators and dial test indicators
- With fine adjustment

Code	Applicable holding stem
6214-A	Ø8mm, Ø4mm, 3/8" DIA.

**VACUUM STAND**

- Diameter of vacuum disc: Ø80mm
- Suitable for granite surface plates or cast iron surface plates
- For digital/dial indicators and dial test indicators

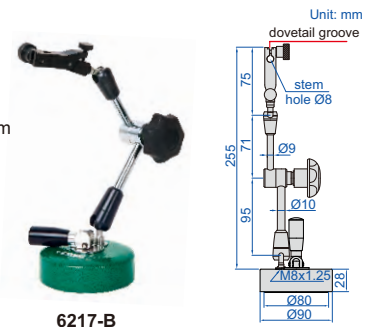

6217-B

Code	Vacuum force	Applicable holding stem	Remark
6217-B	80kgf	Ø8mm	with fine adjustment and dovetail groove

**DIAL INDICATOR STANDS (NON-MAGNETIC)**

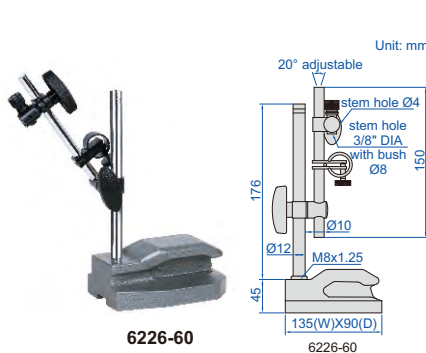

6226-60

6226-60



6226-80

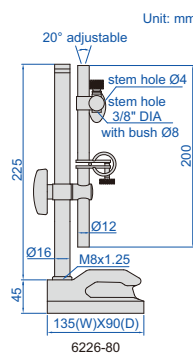

6226-80

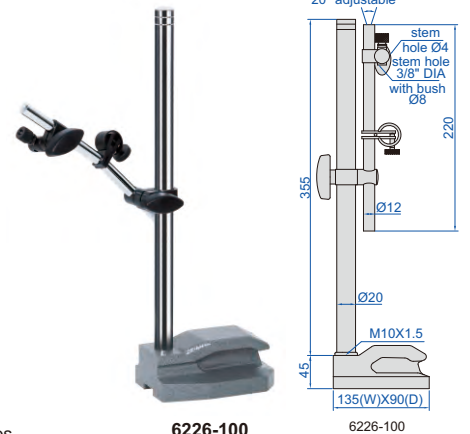

6226-100

6226-100

Code	Applicable holding stem	Remark
6226-60	Ø8mm, Ø4mm, 3/8" DIA	with fine adjustment
6226-80	Ø8mm, Ø4mm, 3/8" DIA	with fine adjustment
6226-100	Ø8mm, Ø4mm, 3/8" DIA	with fine adjustment

- Hardened base
- Suitable for granite surface plates and cast iron surface plates
- For digital/dial indicators and dial test indicators

### DIAL INDICATOR STAND (FOR 0.001MM DIAL AND TEST INDICATORS)

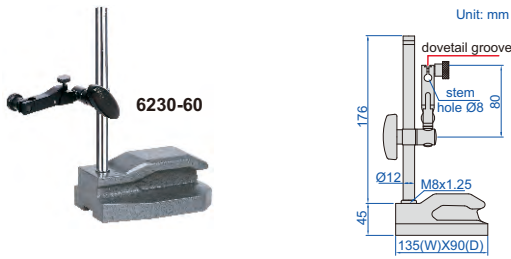

- Non-magnetic and hardened base
- Suitable for granite surface plates or cast iron surface plates
- For 0.001mm and 0.01mm dial and test indicators

Code	Applicable holding stem	Remark
6230-60	Ø8mm	with fine adjustment and dovetail groove

### DIAL INDICATOR STAND (NON-MAGNETIC)

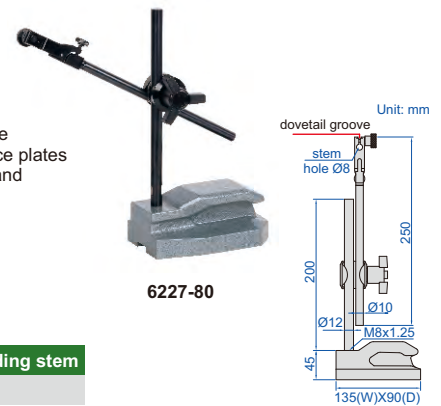

- Hardened base
- Suitable for granite surface plates and cast iron surface plates
- For digital/dial indicators and dial test indicators
- With fine adjustment and dovetail groove

Code	Applicable holding stem
6227-80	Ø8mm

### UNIVERSAL DIAL INDICATOR STANDS (NON-MAGNETIC)

- Hardened base
- Suitable for granite surface plates and cast iron surface plates
- For digital/dial indicators and dial test indicators

Code	Applicable holding stem	Remark
6225-80	Ø8mm	with fine adjustment and dovetail groove
6225-100	Ø8mm	with fine adjustment and dovetail groove

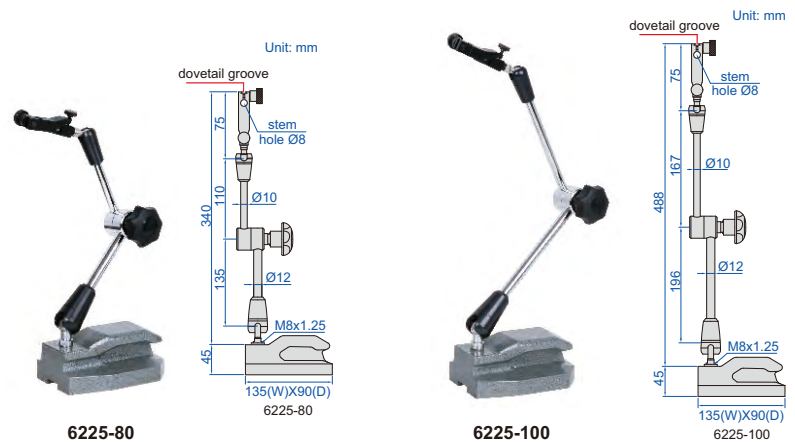

### DIAL INDICATOR STANDS

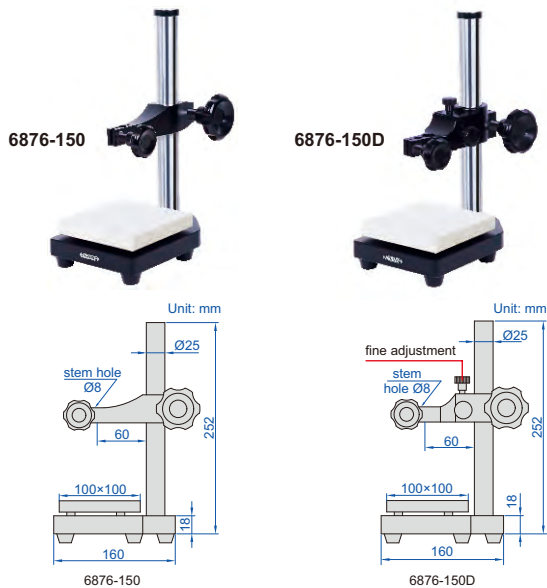

- Vertical travel of holder: 150mm
- Applicable holding stem: Ø8mm
- Ceramic anvil
- Supplied with dust cover

Code	Anvil	Remark
6876-150	ceramic, plain, flatness 1.5µm	without fine adjustment
6876-150D	ceramic, plain, flatness 1.5µm	with fine adjustment, fine adjustment range 3mm

### GRANITE DIAL INDICATOR STANDS (BASIC TYPE)

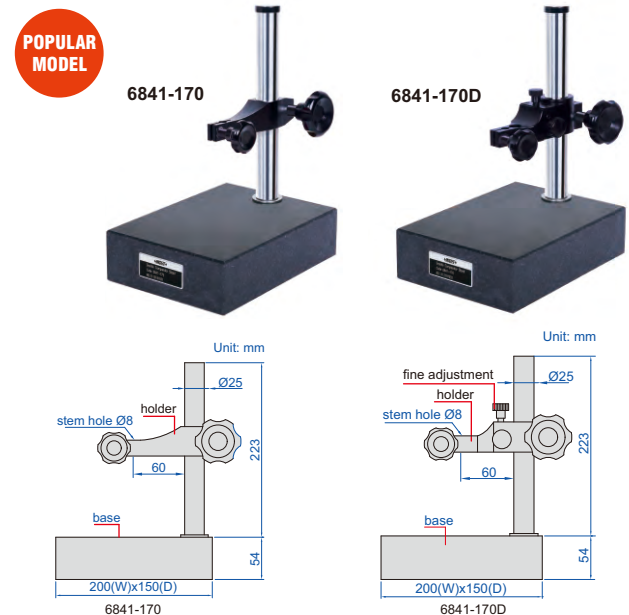

- Vertical travel of holder: 170mm
- Applicable holding stem: Ø8mm
- Supplied with dust cover

Code	Anvil	Remark
6841-170	flatness 2.5µm	without fine adjustment
6841-170D	flatness 2.5µm	with fine adjustment, fine adjustment range 3mm

**GRANITE DIAL INDICATOR STAND**

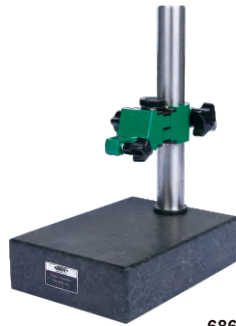
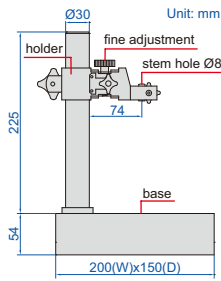

**6866-150**

- Vertical travel of holder: 150mm
- Fine adjustment range: 2mm
- Supplied with dust cover

Code	Applicable holding stem	Base
6866-150	Ø8mm	flatness 2.5µm

**GRANITE DIAL INDICATOR STANDS**

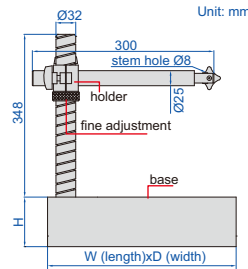

**6867-250**

(mm)

- Vertical travel of holder: 250mm
- Fine adjustment range: entire stroke
- Supplied with dust cover

Code	Applicable holding stem	W	D	H	Base
6867-250	Ø8mm	300	300	75	flatness 2.8µm
6867-400	Ø8mm	400	300	100	flatness 3µm

**DIAL INDICATOR STANDS**

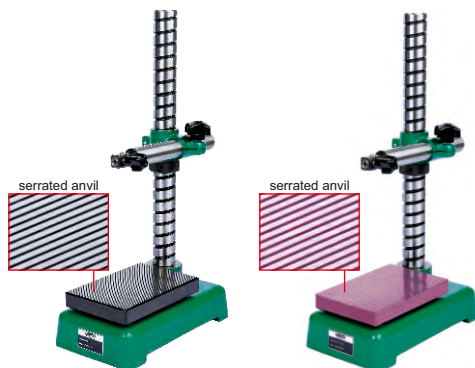

**6864-250**

**6864-250T**

- Vertical travel of holder: 250mm
- Applicable holding stem: Ø8mm
- Fine adjustment range: entire stroke
- Supplied with dust cover

Code	Anvil
6864-250	steel (hardness HRC60±2), serrated, flatness 1.5µm
6864-250T	ceramic, serrated, flatness 1.5µm

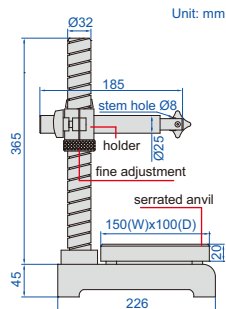

**DIAL INDICATOR STANDS**

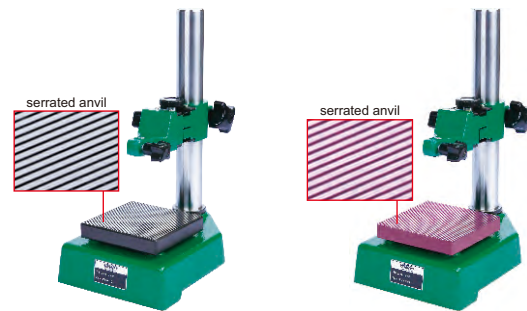

**6863-150**

**6863-150T**

- Vertical travel of holder: 150mm
- Fine adjustment range: 2mm
- Applicable holding stem: Ø8mm
- Supplied with dust cover

Code	Anvil
6863-150	steel (hardness HRC60±2), serrated, flatness 1.5µm
6863-150T	ceramic, serrated, flatness 1.5µm

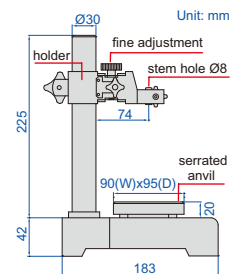

**DIAL INDICATOR STANDS**



**6862-1001**

**6862-1002**

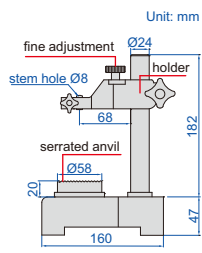

6862-1001  
6862-1001T



**6862-1001T**

**6862-1002T**

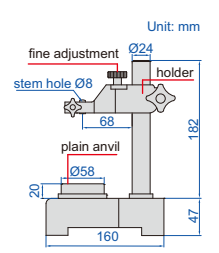

6862-1002  
6862-1002T

Code	Anvil
6862-1001	steel (hardness HRC60±2), serrated, flatness 1.5µm
6862-1002	steel (hardness HRC60±2), plain, flatness 1.5µm
6862-1001T	ceramic, serrated, flatness 1.5µm
6862-1002T	ceramic, plain, flatness 1.5µm

- Vertical travel of holder: 100mm
- Fine adjustment range: 2mm
- Applicable holding stem: Ø8mm
- Supplied with dust cover

## HEAVY DUTY DIAL INDICATOR STAND

- Vertical travel of holder: 300mm
- Fine adjustment range: 5mm
- Carbide base
- Supplied with dust cover
- Optional accessory:  
holder with stem hole  $\varnothing 28$  (code 6869-D28)



6869-300

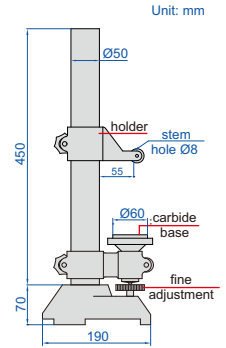

Code	Applicable holding stem	Base
6869-300	$\varnothing 8$ mm	plain, flatness $1\mu\text{m}$ , carbide

## DIAL INDICATOR STAND

GAGE BLOCKS ARE NEEDED FOR ZERO SETTING

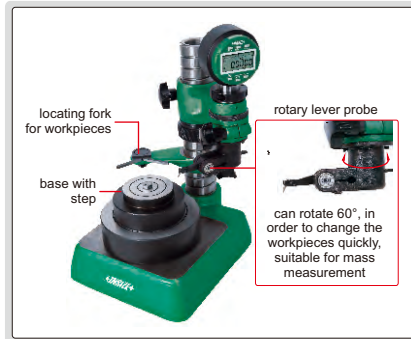

digital/dial indicator is optional

6842-150

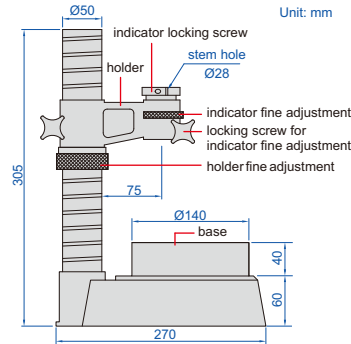

rotary lever probe (included)



base with step (included)



locating fork for workpiece (included)



- Vertical travel of holder: 180mm
- Holder fine adjustment range: entire stroke
- Indicator fine adjustment range: 10mm
- Optional accessory:  $\varnothing 28$ mm/ $\varnothing 8$ mm bush (code 6843-B8), 0.001mm digital/dial indicators, high precision digital indicators (code 2140-6, 2140-6WL), gage blocks (4101 series, for zero setting)

Code	Applicable holding stem	Base
6842-150	$\varnothing 28$ mm	flatness $2\mu\text{m}$

$\varnothing 28$ mm/ $\varnothing 8$ mm bush (optional)

Code

6843-B8



application



the tip of rotary lever probe can reach narrow areas

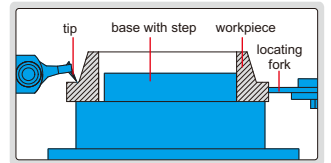

## DIAL INDICATOR STAND

locating fork for workpieces (included)



digital/dial indicator is optional



6845-100

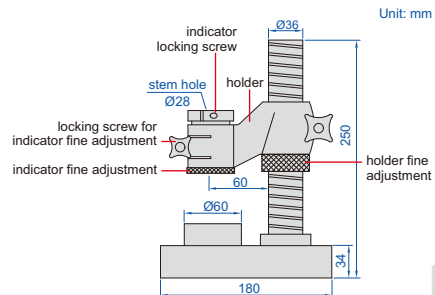

GAGE BLOCKS ARE NEEDED FOR ZERO SETTING

- Vertical travel of holder: 100mm
- Holder fine adjustment range: entire stroke
- Indicator fine adjustment range: 3mm
- Optional accessory:  $\varnothing 28$ mm/ $\varnothing 8$ mm bush (code 6843-B8), 0.001mm digital/dial indicators, high precision digital indicators (code 2140-6, 2140-6WL), gage blocks (4101 series, for zero setting)

Code	Applicable holding stem	Anvil
6845-100	$\varnothing 28$ mm	serrated, flatness $1\mu\text{m}$

$\varnothing 28$ mm/ $\varnothing 8$ mm bush (optional)

Code

6843-B8



application



## TRANSFER STANDS

- Vertical travel of holder: 335mm
- Fine adjustment range: 2mm
- Applicable holding stem: Ø8mm
- Supplied with dust cover

Code	Anvil
6865-300	steel (hardness HRC60±2), plain, flatness 1.5µm
6865-300T	ceramic, plain, flatness 1.5µm



6865-300



6865-300T

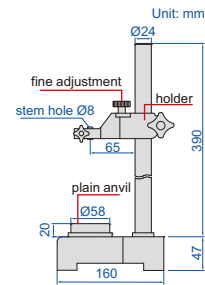

rigid construction, designed to make comparison height measurement (set zero with gage block then measure height of workpiece) with dial indicators or digital indicators (variation of measuring force is high)

## INTERNAL DIAL CALIPER GAGES

Code	Range	Graduation	Accuracy	L	H	W	R
2222-15	5-15mm	0.01mm	±0.02mm	20	2	1.5	R0.3
2222-25	5-25mm	0.01mm	±0.03mm	35	1.5	1.0	R0.3
2222-301	10-30mm	0.01mm	±0.03mm	55	5.5	2.5	R0.5
2222-401	20-40mm	0.01mm	±0.03mm	80	6.0	3.0	R0.5



2222-15

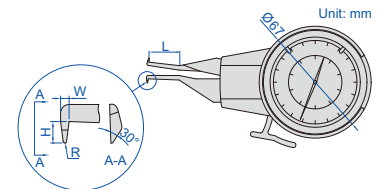

## DIGITAL INTERNAL CALIPER GAGES

DATA OUTPUT



2121-15

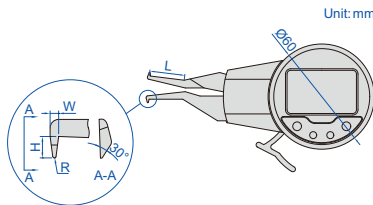
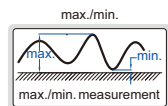

- Resolution: 0.005mm/0.0002"
- Reading in digit and analog
- Display can be rotated by 170°
- Button function: tolerance Go and No-Go display, data preset, max./min. measurement, data holding, inch/metric conversion, absolute/incremental measurement
- CR2032 battery, automatic power off
- Data output
- Optional accessory: data output cable (code 7315-30 need receiver, 7302-30)

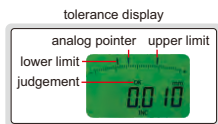

Code	Range	Accuracy	Repeatability	L	H	W	R
2121-15	5-15mm/0.2-0.6"	±0.03mm	0.01mm	20	2	1.5	R0.3
2121-25	5-25mm/0.2-1.0"	±0.03mm	0.01mm	35	1.5	1.0	R0.3
2121-31	10-30mm/0.4-1.2"	±0.03mm	0.01mm	55	5.5	2.5	R0.5
2121-41	20-40mm/0.8-1.6"	±0.03mm	0.01mm	80	6.0	3.0	R0.5

## DIGITAL INTERNAL CALIPER GAGES

DATA OUTPUT

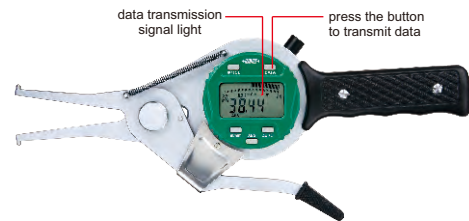

2151-35

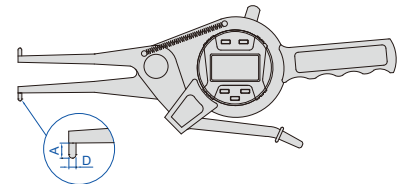
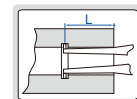

- Accuracy: ±0.04mm
- Carbide measuring tips
- Reading in digit and analog
- With transmission button and signal light
- Display can be rotated by 320°
- Button function: on/off, zero, tolerance Go and No-Go display, data preset, measuring direction change, max./min./TIR measurement, inch/metric conversion, data output, absolute/incremental measurement
- CR2032 battery, automatic power off (time is adjustable)
- Data output
- Optional accessory: data output cable (code 7315-50M need receiver, 7302-50M)

Code	Range	Resolution	L	A	D
2151-35	15-35mm/0.6-1.4"	0.01mm/0.0005"	<50	3	Ø3
2151-55	35-55mm/1.4-2.2"	0.01mm/0.0005"	<80	6	Ø3
2151-75	55-75mm/2.2-3"	0.01mm/0.0005"	<90	8	Ø3
2151-95	75-95mm/3-3.8"	0.01mm/0.0005"	<100	8	Ø3
2151-115	95-115mm/3.8-4.6"	0.01mm/0.0005"	<120	10	Ø3.2
2151-135	115-135mm/4.6-5.4"	0.01mm/0.0005"	<120	10	Ø3.2

## INTERNAL DIAL CALIPER GAGES WITH INTERCHANGEABLE POINTS



2223-153

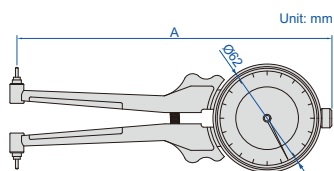

Unit: mm

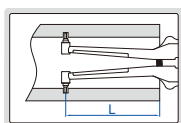

- Graduation: 0.01mm

2223-35 points (included)

Unit: mm

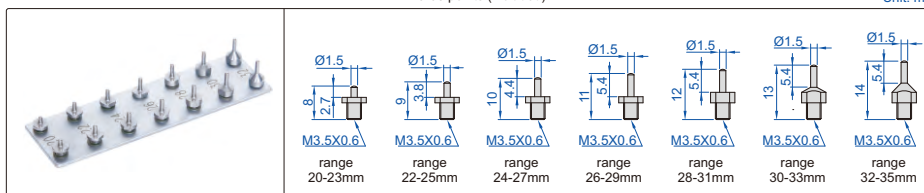

2223-62 points (included)

Unit: mm

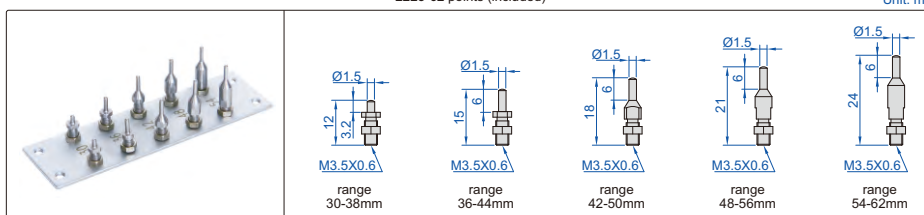

2223-153 points (included)

Unit: mm

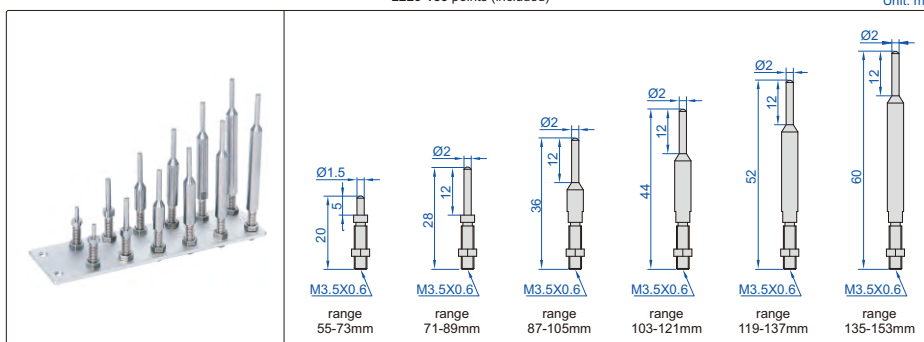

Code	Range	Dial indicator range	Accuracy	A	L	Remark
2223-35	20-35mm	2mm	±0.02mm	164mm	<70mm	supplied with 7 pairs of points
2223-62	30-62mm	2mm	±0.02mm	170mm	<75mm	supplied with 5 pairs of points
2223-153	55-153mm	2mm	±0.02mm	179mm	<90mm	supplied with 6 pairs of points

## DIGITAL EXTERNAL CALIPER GAGE

DATA OUTPUT

- Carbide measuring tips
- Reading in digit and analog
- With transmission button and signal light
- Display can be rotated by 320°
- Button function: on/off, zero, tolerance Go and No-Go display, data preset, measuring direction change, max./min./TIR measurement, inch/metric conversion, absolute/incremental measurement, data output
- CR2032 battery, automatic power off (time is adjustable)
- Data output
- Optional accessory: data output cable (code 7315-50M need receiver, 7302-50M)



2132-20

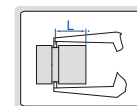

Unit: mm

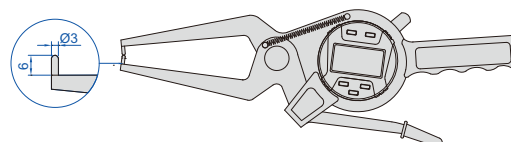

Code	Range	Resolution	Accuracy	L
2132-20	0-20mm/0-0.8"	0.01mm/0.0005"	±0.04mm	<60mm

## EXTERNAL DIAL CALIPER GAGE

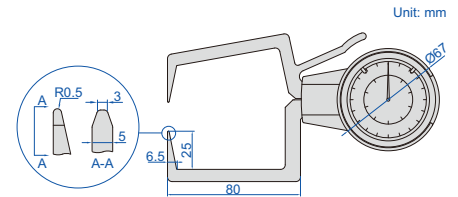

Code	Range	Graduation	Accuracy
2333-201	0-20mm	0.01mm	±0.03mm

2333-201

## DIGITAL EXTERNAL CALIPER GAGE



2131-21

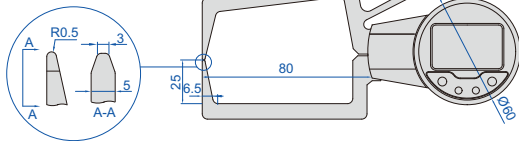

- Resolution: 0.005mm/0.0002"
- Repeatability: 0.01mm
- Reading in digit and analog
- Display can be rotated by 170°
- Button function: tolerance Go and No-Go display, data preset, max./min. measurement, data holding, inch/metric conversion, absolute/incremental measurement
- CR2032 battery, automatic power off
- Data output
- Optional accessory: data output cable (code 7315-30 need receiver, 7302-30)

DATA OUTPUT

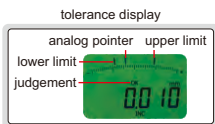
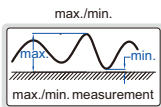

Code	Range	Accuracy
2131-21	0-20mm/0-0.8"	±0.03mm

## THICKNESS GAGES



2364-10



2364-1

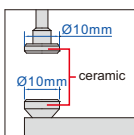

(mm)

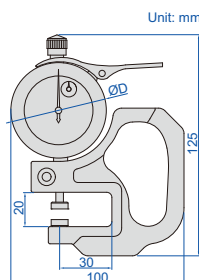

Code	Range	Graduation	Accuracy	ØD
2364-10	0-10mm	0.01mm	±0.02mm	58
2364-1	0-1mm	0.001mm	±0.005mm	56

## DIGITAL THICKNESS GAGES

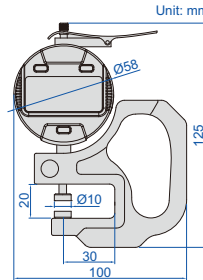

2871-101

- Ceramic spindle tip and anvil
- Button function: on/off, inch/mm, zero, data preset, change measuring direction, absolute/incremental measurement
- Keep preset data in memory after restart
- CR2032 battery, automatic power off (time is adjustable)
- Data output
- Optional accessory: data output cable (code 7315-50M need receiver, 7302-50M)

POPULAR MODEL

DATA OUTPUT

Code	Range	Resolution	Accuracy
2871-10	0-10mm/0-0.4"	0.01mm/0.0005"	±0.02mm
2871-101	0-10mm/0-0.4"	0.001mm/0.00005"	±0.005mm

## DIGITAL THICKNESS GAGE



2872-10

measuring tips and anvils can be custom-made

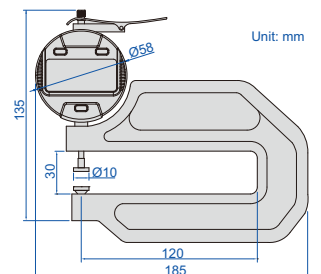

- Ceramic spindle tip and anvil
- Buttons: on/off, inch/mm, zero, data preset, change measuring direction, absolute/incremental measurement
- Keep preset data in memory after restart
- Battery CR2032, data output
- Automatic power off (time is adjustable)
- Optional accessory: data output cable (code 7315-50M need receiver, 7302-50M)

Code	Range	Resolution	Accuracy
2872-10	0-10mm/0-0.4"	0.01mm/0.0005"	±0.02mm



### THICKNESS GAGE

SUITABLE FOR JEWELLERY

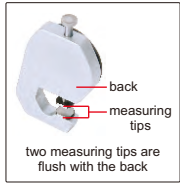

2361-10

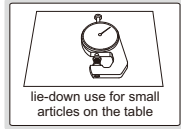
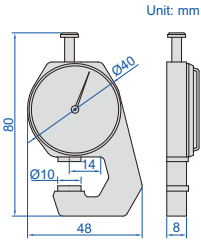

Code	Range	Graduation	Accuracy
2361-10	0-10mm	0.1mm	±0.05mm

### THICKNESS GAGE



2862-101

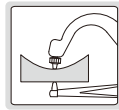
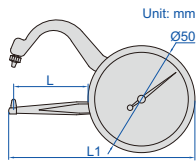

Code	Range	Graduation	Accuracy	L	L1
2862-101	0-10mm	0.05mm	±0.1mm	35mm	85mm

### THICKNESS GAGE



2870-10

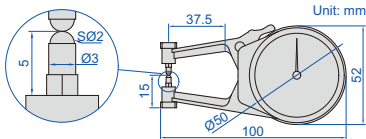

- Graduation: 0.1mm
- Main body is made of hard plastic

Code	Range	Accuracy
2870-10	0-10mm	±0.1mm

### HIGH PRECISION DIGITAL THICKNESS GAGES

ATTENTION: RECHARGEABLE BATTERY, FOR 12 HOURS CONTINUOUS WORKING

MEASURING TIPS AND ANVILS CAN BE CUSTOM-MADE

ABSOLUTE ENCODER, THE ORIGINAL DATA REMAINS AFTER POWER OFF

DATA OUTPUT



2879-10

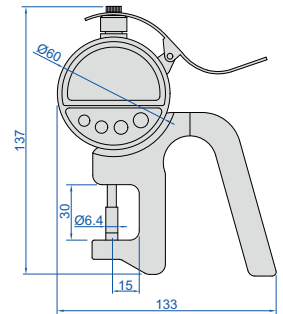

- Absolute encoder, the original data remains after power off
- Button function: on/off, zero, tolerance, absolute/incremental measurement, max./min./TIR, data preset, mm/inch, data output, data hold
- Measuring force: 0.5-1N
- Reading in digital and analog
- Power: rechargeable battery, for 12 hours continuous working
- Data output
- Supplied with data output cable (keyboard format)

Code	Range	Resolution	Accuracy	Repeatability
2879-10	0-10mm/0-0.4"	0.001mm/0.00005"	±0.002mm	0.001mm
2879-101	0-10mm/0-0.4"	0.0005mm/0.00002"	±0.0015mm	0.0005mm

### THICKNESS GAGE

- Graduation: 0.01mm
- Stainless steel spindle tip and anvil



2363-10

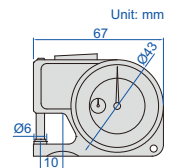

Code	Range	Accuracy
2363-10	0-10mm	±0.03mm

### DIGITAL TUBE THICKNESS GAGE

DATA OUTPUT

- Buttons: on/off, inch/mm, zero, data preset, change measuring direction, absolute/incremental measurement
- Keep preset data in memory after restart
- Battery CR2032, automatic power off (time is adjustable)
- Data output
- Optional accessory: data output cable (code 7315-50M need receiver, 7302-50M)

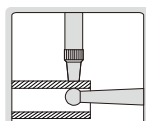

2876-10

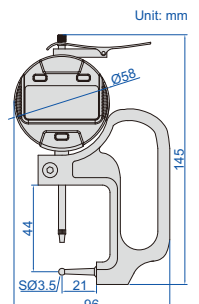

Code	Range	Resolution	Accuracy
2876-10	0-10mm/0-0.4"	0.01mm/0.0005"	±0.02mm

## DIGITAL RUBBER THICKNESS GAGES

DATA OUTPUT



2878-6B

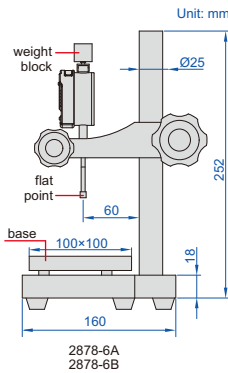

2878-71B

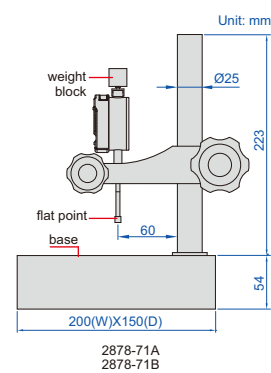

- Flat point diameter: 6mm
- Measure thickness of vulcanized rubber and plastic products
- Button function: on/off, inch/mm, zero, data preset, change measuring direction, absolute/incremental measurement
- CR2032 battery, automatic power off (time is adjustable)
- Supplied with dust cover
- Optional accessory: data output cable (code 7315-50M need receiver, 7302-50M), flat points, weight blocks

Code	Range	Resolution	Accuracy	Pressure	Base
2878-6A	12.7mm/0.5"	0.01mm/0.0005"	20µm	22kPa±5kPa	ceramic, plain, flatness 1.5µm
2878-6B	12.7mm/0.5"	0.001mm/0.00005"	5µm	22kPa±5kPa	ceramic, plain, flatness 1.5µm
2878-71A	12.7mm/0.5"	0.01mm/0.0005"	20µm	22kPa±5kPa	granite, plain, flatness 2.5µm
2878-71B	12.7mm/0.5"	0.001mm/0.00005"	5µm	22kPa±5kPa	granite, plain, flatness 2.5µm

### Flat points and weight blocks (optional)

Flat point	Flat point code	Pressure				
		10kPa±2kPa	22kPa±5kPa	20kPa±3kPa	70kPa±5kPa	1.6kPa±0.1kPa
		weight block code	weight block code	weight block code	weight block code	weight block code
Ø4mm	2878-P4	—	2878-W4B	—	—	—
Ø5mm	2878-P5	2878-W5A	2878-W5B	2878-W5C	2878-W5D	—
Ø6mm	2878-P6	2878-W6A	2878-W6B	—	—	—
Ø8mm	2878-P8	2878-W8A	2878-W8B	—	—	—
Ø10mm	2878-P10	2878-W10A	2878-W10B	2878-W10C	—	—
Ø25mm	2878-P25	—	—	—	—	2878-W25E
1x4mm (rectangle)	2878-P14	—	—	—	2878-W14D	—

## DIAL SNAP GAGES

QUICK AND ACCURATE MEASUREMENT OF CYLINDRICAL WORKPIECES

- Left anvil retracting stroke: 2mm
- Measuring force: 6-8N
- Flatness of anvil: 1.5µm
- Repeatability: 1µm
- Carbide measuring faces for anvils
- Front edges of anvils are chamfered for easy workpiece insertion
- Optional accessory: dial indicators and digital indicators (reading 0.001mm or 0.01mm)



2186-25

INSPECTION CERTIFICATE



Code	Range	Parallelism of measuring faces	(mm)		
			A	B	C
2186-25*	0-25mm	4µm	42	11-18	20
2186-50*	25-50mm	4µm	69	11-32	41
2186-75*	50-75mm	5µm	94	17-41	51
2186-100*	75-100mm	6µm	119	31-55	65

\*Supplied with manufacturer inspection certificate

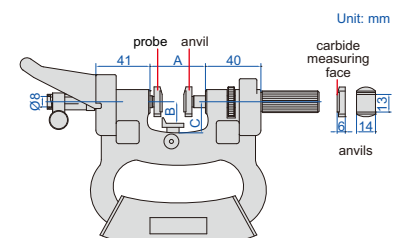

### DIAL SNAP GAGE

ATTENTION: NOT SUITABLE FOR 0.001MM DIAL INDICATORS

- Quick measurement for mass production
- Anvil retracting stroke: 3mm
- Measuring force: 6-9N
- Carbide measuring faces
- Optional accessory: dial indicators (graduation 0.01mm), digital indicators (resolution 0.01mm/0.0005")



digital indicator is optional

2184-25W

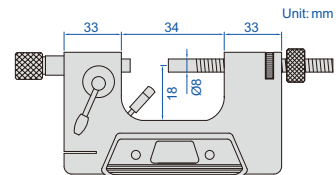

Code	Range
2184-25W	0-25mm

### DIAL SNAP GAGES

ATTENTION: SETTING STANDARDS ARE NOT INCLUDED

IP54 WATERPROOF



3334-25

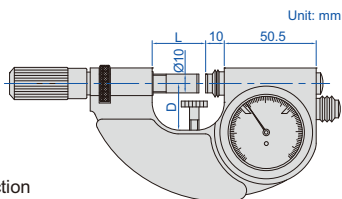

- Quick measurement for mass production
- Dial indicator: range  $\pm 0.04$ mm, graduation 0.001mm, accuracy 0.001mm
- IP54 dust/waterproof
- Measuring force: 5-10N
- Carbide measuring faces
- Optional accessory: gage blocks grade 0 (4101-A series), for zero setting

Code	Range	L	D
3334-25	0-25mm	28.5mm	25mm
3334-50	25-50mm	53.5mm	35mm
3334-75	50-75mm	78.5mm	47.5mm
3334-100	75-100mm	103.5mm	60mm

### DIGITAL SNAP GAGE

ATTENTION: NO DATA OUTPUT



2166-12

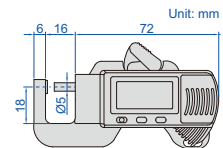

Code	Range	Resolution	Accuracy
2166-12	0-12mm/0-0.5"	0.01mm/0.0005"	$\pm 0.03$ mm

### DIGITAL 3-PURPOSE SNAP GAGE

ATTENTION: NO DATA OUTPUT

SUITABLE FOR JEWELLERY



2164-25A

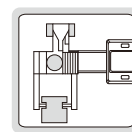

- Non waterproof
- Resolution: 0.01mm/0.0005"
- Buttons: zero, mm/inch, on/off
- Battery LR44
- Made of stainless steel

Code	Range	Accuracy
2164-25A	0-25mm/0-1"	$\pm 0.03$ mm

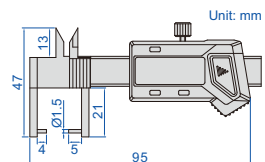

### STEP AND GAP GAGE

DATA OUTPUT

- Non waterproof
- Resolution: 0.01mm/0.0005"
- Measure step height and gap width
- Buttons: on/off, set, mm/inch, preset (+, -)
- Automatic power off, move the digital unit to turn on power
- Battery CR2032, data output
- Made of stainless steel
- Supplied with zero setting block
- Optional accessory: data output cable (code 7315-21 need receiver, 7302-21)



front

2168-12

back

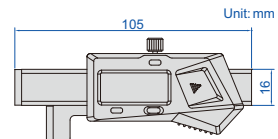
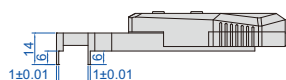

zero setting block (included)



Code	Range	Accuracy
2168-12	0-12.7mm/0-0.5"	$\pm 0.03$ mm

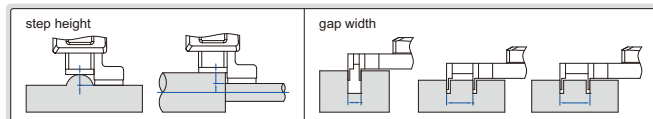

### MINI DIGITAL HEIGHT GAGE

DATA OUTPUT

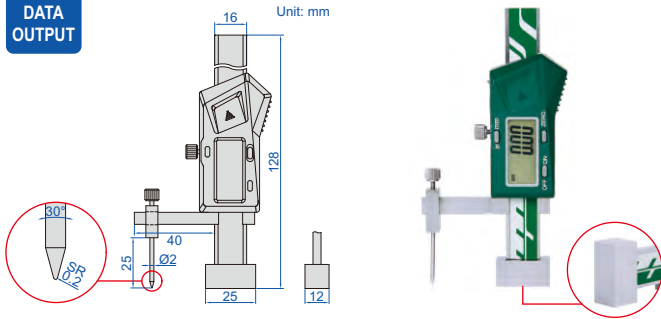

1146-20A

- Non waterproof
- Measure height difference of two surfaces
- Resolution: 0.01mm/0.0005"
- Buttons: on/off, zero, mm/inch
- Automatic power off, move the digital unit to turn on power
- Battery CR2032, data output
- Made of stainless steel
- Optional accessory: data output cable (code 7315-21 need receiver, 7302-21)

Code	Range	Accuracy
1146-20A	0~±20mm/0~±0.8"	±0.02mm

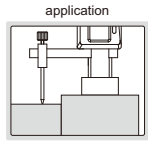

### MINI VERNIER HEIGHT GAGE

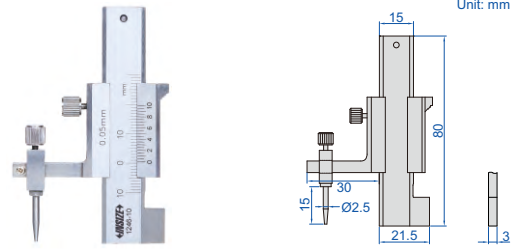

1246-10

- Measure height difference of two surfaces
- Graduation: 0.05mm
- Made of stainless steel
- Satin chrome plated reading surface

Code	Range	Accuracy
1246-10	0~±10mm	±0.05mm

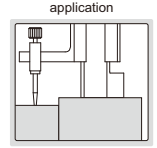

### DIAL HEIGHT GAGES

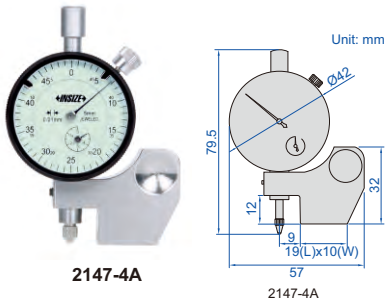

2147-4A

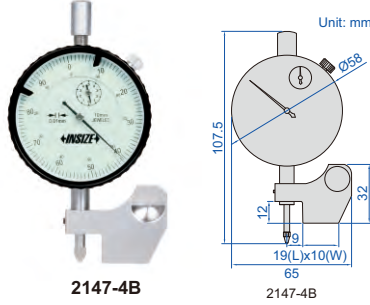

2147-4B

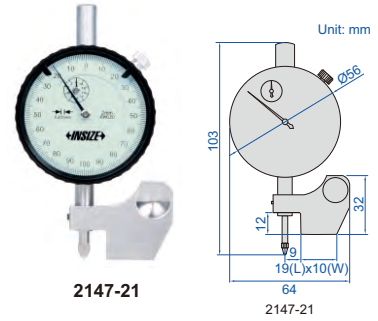

2147-21

2147-21

- Measure height difference of two surfaces

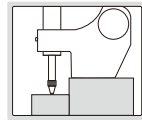

Code	Range	Dial indicator stroke	Dial indicator graduation	Accuracy
2147-4A	0~±5mm (adjustable)	5mm	0.01mm	±0.014mm
2147-4B	0~±5mm	10mm	0.01mm	±0.017mm
2147-21	0~±2mm (adjustable)	2mm	0.001mm	±0.006mm

### DIGITAL HEIGHT GAGES

DATA OUTPUT

- Measure height difference of two surfaces
- Button function: on/off, inch/mm, zero, data preset, change measuring direction, absolute/incremental measurement
- Keep preset data in memory after restart
- CR2032 battery, automatic power off (time is adjustable)
- Data output
- Optional accessory: data output cable (code 7315-50M need receiver, 7302-40M)

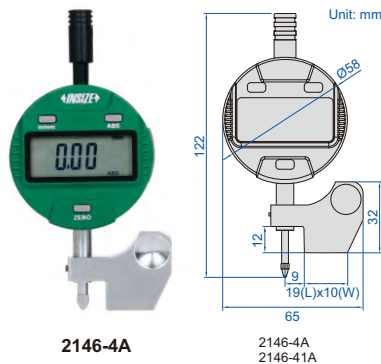

2146-4A

2146-4A  
2146-41A

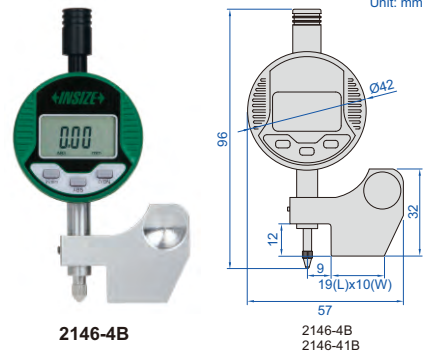

2146-4B

2146-4B  
2146-41B

Code	Range (adjustable)	Digital indicator stroke	Digital indicator resolution	Accuracy
2146-4A	0~4mm/0~0.16" (sunked)	12.7mm/0.5"	0.01mm/0.0005"	±0.02mm
2146-41A	0~12.7mm/0~0.5" (raised)	12.7mm/0.5"	0.001mm/0.00005"	±0.005mm
2146-4B	0~4mm/0~0.16" (sunked)	5mm/0.2"	0.01mm/0.0005"	±0.02mm
2146-41B	0~5mm/0~0.2" (raised)	5mm/0.2"	0.001mm/0.00005"	±0.005mm

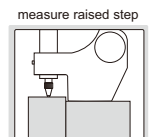
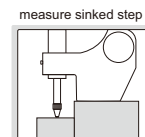

## CRANKSHAFT TESTERS



2841-500

- To test crankshaft deflection
- The balance block is mounted on the back of dial indicator to keep the dial indicator facing up

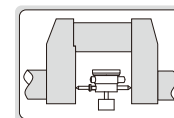
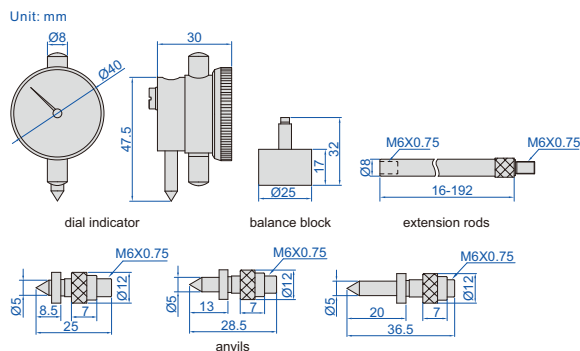

Code	Range	Dial indicator range	Extension rods	Accuracy	Graduation
2841-300	60-300mm	3mm	16mm, 32mm, 64mm, 128mm	±0.016mm	0.01mm
2841-500	60-500mm	3mm	16mm, 32mm, 64mm, 96mm, 128mm, 192mm	±0.016mm	0.01mm

## DIGITAL KEYWAY DEPTH GAGE

- Measure keyway depth of cylindrical workpieces with diameter Ø10-100mm
- Button function: on/off, zero, inch/metric conversion, absolute/incremental measurement, data preset, measuring direction change
- CR2032 battery
- Automatic power off (time is adjustable)
- Data output
- Stainless steel base
- Pointed tip
- Optional accessory: data output cable (code 7315-50M need receiver, 7302-40M)

2182-25

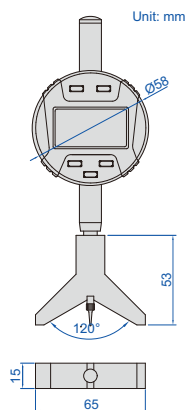

DATA OUTPUT

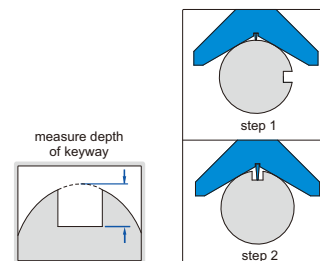

Code	Range	Accuracy	Resolution
2182-25	0-25.4mm/0-1"	±0.02mm	0.01mm/0.0005"

## STEEL GAGE BLOCK SETS

INSPECTION CERTIFICATE

POPULAR MODEL



4100-87

- Made of alloy steel
- Meet ISO3650
- Gage blocks ≥ 125mm have clamping holes
- Supplied with manufacturer inspection certificate

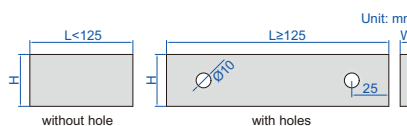

Dimension:	(mm)
Size (L)	W H
0.5 ≤ L ≤ 10mm	9 30
L > 10mm	9 35

Blocks per set	Gage blocks included in set			Code		
	Size (mm)	Step (mm)	Quantity	Grade 1	Grade 2	
122	1.0005	0.001	1	4100-1122	4100-2122	
	1.001-1.009		9			
	1.01-1.49		0.01			49
	1.6-1.9		0.1			4
	0.5-24.5		0.5			49
	30-100		10			8
112	1.0005	0.001	1	4100-1112	4100-2112	
	1.001-1.009		9			
	1.01-1.49		0.01			49
	0.5-24.5		0.5			49
	25-100		25			4
103	1.005	0.01	1	4100-1103	4100-2103	
	1.01-1.49		49			
	0.5-24.5		49			
	25-100		25			
			4			

Blocks per set	Gage blocks included in set			Code			
	Size (mm)	Step (mm)	Quantity	Grade 0	Grade 1	Grade 2	
87	1.001-1.009	0.001	9	4100-87	4100-187	4100-287	
	1.01-1.49	0.01	49				
	0.5-9.5	0.5	19				
	10-100	10	10				
47	1.005	0.01	1	4100-47	4100-147	4100-247	
	1.01-1.19		0.1				19
	1.2-1.9		1				8
	1-9		1				9
	10-100		10				10
32	1.005	0.01	1	4100-32	4100-132	4100-232	
	1.01-1.09		0.01				9
	1.1-1.9		0.1				9
	1-9		1				9
	10-30		10				3
	50						1
8	125-175	25	3	4100-8	4100-18	4100-28	
	200-250	50	2				
	300-500	100	3				

**STEEL INDIVIDUAL GAGE BLOCKS**

**CUSTOM-MADE**  
CAN SUPPLY ANY SIZES FROM 0.5  
TO 1000MM, SUCH AS 72.672MM

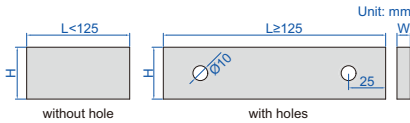

4101-A70

4101-A200

- Grade 0, 1 and 2 gage blocks are available
- Made of alloy steel
- Meet ISO3650
- Gage blocks with clamping holes: 125, 150, 175, 200, 250, 300, 400, 500, 600, 700, 800, 900, 1000mm
- Supplied with manufacturer inspection certificate

Dimension: (mm)

Size (L)	W	H
0.5 ≤ L ≤ 10mm	9	30
L > 10mm	9	35

Grade 0 (mm)

Code	Size
4101-A1	1
4101-A10	10
4101-A100	100

Grade 2 (mm)

Code	Size
4101-C1	1
4101-C10	10
4101-C100	100
4101-C200	200
4101-C250	250
4101-C300	300

Grade 1 (mm)		Grade 1 (mm)		Grade 1 (mm)		Grade 1 (mm)		Grade 1 (mm)	
Code	Size	Code	Size	Code	Size	Code	Size	Code	Size
4101-BD5	0.5	4101-B1D12	1.12	4101-B1D4	1.4	4101-B5	5	4101-B22	22
4101-B1	1	4101-B1D15	1.15	4101-B1D42	1.42	4101-B5D5	5.5	4101-B23	23
4101-B1D001	1.001	4101-B1D16	1.16	4101-B1D43	1.43	4101-B6	6	4101-B25	25
4101-B1D002	1.002	4101-B1D18	1.18	4101-B1D45	1.45	4101-B7	7	4101-B30	30
4101-B1D003	1.003	4101-B1D19	1.19	4101-B1D46	1.46	4101-B7D5	7.5	4101-B35	35
4101-B1D004	1.004	4101-B1D2	1.2	4101-B1D47	1.47	4101-B8	8	4101-B40	40
4101-B1D005	1.005	4101-B1D21	1.21	4101-B1D48	1.48	4101-B8D5	8.5	4101-B45	45
4101-B1D006	1.006	4101-B1D22	1.22	4101-B1D49	1.49	4101-B9	9	4101-B50	50
4101-B1D009	1.009	4101-B1D24	1.24	4101-B1D5	1.5	4101-B9D5	9.5	4101-B60	60
4101-B1D01	1.01	4101-B1D25	1.25	4101-B1D6	1.6	4101-B10	10	4101-B70	70
4101-B1D02	1.02	4101-B1D26	1.26	4101-B1D7	1.7	4101-B11	11	4101-B75	75
4101-B1D03	1.03	4101-B1D27	1.27	4101-B1D8	1.8	4101-B12	12	4101-B80	80
4101-B1D04	1.04	4101-B1D3	1.3	4101-B1D9	1.9	4101-B13	13	4101-B90	90
4101-B1D05	1.05	4101-B1D32	1.32	4101-B2	2	4101-B14	14	4101-B100	100
4101-B1D06	1.06	4101-B1D33	1.33	4101-B2D5	2.5	4101-B15	15	4101-B125	125
4101-B1D07	1.07	4101-B1D34	1.34	4101-B3	3	4101-B16	16	4101-B131D4	131.4
4101-B1D08	1.08	4101-B1D35	1.35	4101-B3D5	3.5	4101-B18	18	4101-B150	150
4101-B1D09	1.09	4101-B1D36	1.36	4101-B4	4	4101-B20	20		
4101-B1D1	1.1	4101-B1D37	1.37	4101-B4D5	4.5	4101-B21	21		

**CALIPER INSPECTION GAGE BLOCK AND RING GAGE SET**

- Gage blocks meet ISO3650
- Ring gages meet DIN2250-1:2008
- Supplied with manufacturer inspection certificate

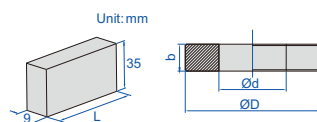

4176-30

Ring gage sizes:

diameter (Ød)*	b	ØD
Ø10mm	8mm	32mm
Ø25mm	14mm	53mm

\* The size of the ring gage when supplied may have deviation. For example, the size Ø25mm may be 24.996mm

Grade of gage blocks: 2 (mm)

Code	Material	Gage blocks included in set (L)	Ring gages included in set (Ød)	Applicable calipers
4176-30	alloy steel	30, 41.3, 131.4	10, 25	0-150

## CALIPER INSPECTION GAGE BLOCK SET



- Meet ISO3650/grade 2
- Supplied with manufacturer inspection certificate

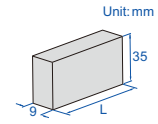

4108-3005

Code	Material	Gage blocks included in set (L)	Applicable calipers
4108-3005	alloy steel	30, 41.3, 131.4, 243.5, 281.2	0-150, 0-200, 0-300

## MICROMETER INSPECTION GAGE BLOCK SET



- Meet ISO3650/grade 0
- One piece of optical flat is included (size Ø30x12mm)
- Supplied with manufacturer inspection certificate

optical flat (included)

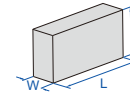

Dimension:

Size (L)	W	H
0.5 ≤ L ≤ 10mm	9mm	30mm
L > 10mm	9mm	35mm



4160-10

Code	Material	Gage blocks included in set	Applicable micrometer
4160-10	alloy steel	2.5mm, 5.1mm, 7.7mm, 10.3mm, 12.9mm, 15mm, 17.6mm, 20.2mm, 22.8mm, 25mm	0-25mm



## CALIPER/HEIGHT GAGE CHECKERS

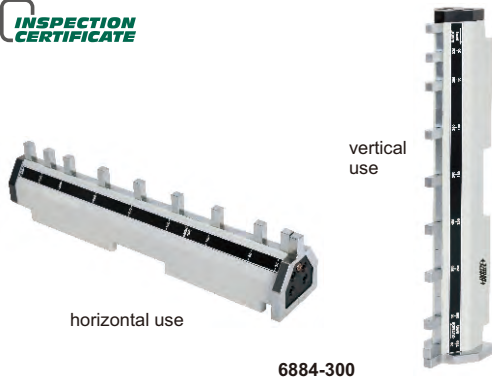

6884-300

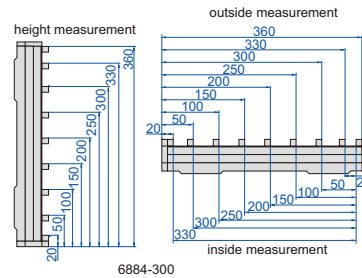

6884-300

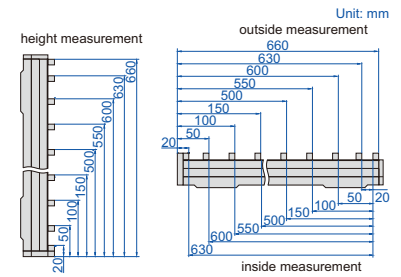

6884-600

- To check calipers and height gages
- Constructed with steel gage blocks

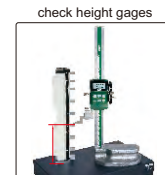
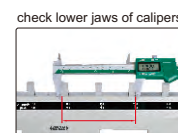
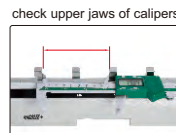

Code	Size	Range of inside measurement	Range of outside measurement	Range of height measurement	Accuracy
6884-300 *	0-300mm	20, 50, 100, 150, 200, 250, 300, 330	20, 50, 100, 150, 200, 250, 300, 330, 360	20, 50, 100, 150, 200, 250, 300, 330, 360	±3µm
6884-600 *	0-600mm	20, 50, 100, 150, 200, 250, 300, 350, 400, 450, 500, 550, 600, 630	20, 50, 100, 150, 200, 250, 300, 350, 400, 450, 500, 550, 600, 630, 660	20, 50, 100, 150, 200, 250, 300, 350, 400, 450, 500, 550, 600, 630, 660	±5µm

\*Supplied with manufacturer inspection certificate

## INSIDE MICROMETER ACCESSORY

- Supplied with a pair of 5mm carbide gage blocks

Code
6884-A10 *

\*Supplied with manufacturer inspection certificate



6884-A10

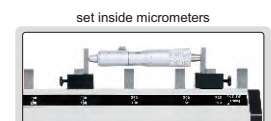

## STEEL PIN GAGE SETS

POPULAR MODEL

Code	Diameter Ød (mm)	Step	Pin gages per set
4166-2S	1.00, 1.01, 1.02, … 2.00	0.01mm	101
4166-3S	2.00, 2.01, 2.02, … 3.00	0.01mm	101
4166-4S	3.00, 3.01, 3.02, … 4.00	0.01mm	101
4166-5S	4.00, 4.01, 4.02, … 5.00	0.01mm	101
4166-6S	5.00, 5.01, 5.02, … 6.00	0.01mm	101
4166-7S	6.00, 6.01, 6.02, … 7.00	0.01mm	101
4166-8S	7.00, 7.01, 7.02, … 8.00	0.01mm	101
4166-9S	8.00, 8.01, 8.02, … 9.00	0.01mm	101
4166-10S	9.00, 9.01, 9.02, … 10.00	0.01mm	101

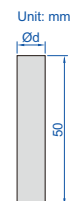

4166-10

Code	Diameter Ød (mm)	Step	Pin gages per set
4166-411	1.0, 1.1, 1.2, … 5.0	0.01mm	41
4166-511	5.0, 5.1, 5.2, … 10.0	0.01mm	51
4166-512	10.0, 10.1, 10.2, … 15.0	0.01mm	51
4166-513	15.0, 15.1, 15.2, … 20.0	0.01mm	51

- Meet DIN2269, grade 1
- Made of alloy steel
- Hardness HRC62-65
- Diameter accuracy:  $\pm 1\mu\text{m}$

Code	Diameter Ød (mm)	Step	Pin gages per set
4166-0D	0.20, 0.21, 0.22, … 0.50	0.01mm	31
4166-1	0.50, 0.51, 0.52, … 1.00	0.01mm	51
4166-1D	1.00, 1.01, 1.02, … 1.50	0.01mm	51
4166-2	1.50, 1.51, 1.52, … 2.00	0.01mm	51
4166-2D	2.00, 2.01, 2.02, … 2.50	0.01mm	51
4166-3	2.50, 2.51, 2.52, … 3.00	0.01mm	51
4166-3D	3.00, 3.01, 3.02, … 3.50	0.01mm	51
4166-4	3.50, 3.51, 3.52, … 4.00	0.01mm	51
4166-4D	4.00, 4.01, 4.02, … 4.50	0.01mm	51
4166-5	4.50, 4.51, 4.52, … 5.00	0.01mm	51
4166-5D	5.00, 5.01, 5.02, … 5.50	0.01mm	51
4166-6	5.50, 5.51, 5.52, … 6.00	0.01mm	51
4166-6D	6.00, 6.01, 6.02, … 6.50	0.01mm	51
4166-7	6.50, 6.51, 6.52, … 7.00	0.01mm	51
4166-7D	7.00, 7.01, 7.02, … 7.50	0.01mm	51
4166-8	7.50, 7.51, 7.52, … 8.00	0.01mm	51
4166-8D	8.00, 8.01, 8.02, … 8.50	0.01mm	51
4166-9	8.50, 8.51, 8.52, … 9.00	0.01mm	51
4166-9D	9.00, 9.01, 9.02, … 9.50	0.01mm	51
4166-10	9.50, 9.51, 9.52, … 10.00	0.01mm	51

Code	Diameter Ød (mm)	Step	Pin gages per set
4166-10D	10.00, 10.01, 10.02, … 10.50	0.01mm	51
4166-11	10.50, 10.51, 10.52, … 11.00	0.01mm	51
4166-11D	11.00, 11.01, 11.02, … 11.50	0.01mm	51
4166-12	11.50, 11.51, 11.52, … 12.00	0.01mm	51
4166-12D	12.00, 12.01, 12.02, … 12.50	0.01mm	51
4166-13	12.50, 12.51, 12.52, … 13.00	0.01mm	51
4166-13D	13.00, 13.01, 13.02, … 13.50	0.01mm	51
4166-14	13.50, 13.51, 13.52, … 14.00	0.01mm	51
4166-14D	14.00, 14.01, 14.02, … 14.50	0.01mm	51
4166-15	14.50, 14.51, 14.52, … 15.00	0.01mm	51
4166-15D	15.00, 15.01, 15.02, … 15.50	0.01mm	51
4166-16	15.50, 15.51, 15.52, … 16.00	0.01mm	51
4166-16D	16.00, 16.01, 16.02, … 16.50	0.01mm	51
4166-17	16.50, 16.51, 16.52, … 17.00	0.01mm	51
4166-17D	17.00, 17.01, 17.02, … 17.50	0.01mm	51
4166-18	17.50, 17.51, 17.52, … 18.00	0.01mm	51
4166-18D	18.00, 18.01, 18.02, … 18.50	0.01mm	51
4166-19	18.50, 18.51, 18.52, … 19.00	0.01mm	51
4166-19D	19.00, 19.01, 19.02, … 19.50	0.01mm	51
4166-20	19.50, 19.51, 19.52, … 20.00	0.01mm	51



## STEEL INDIVIDUAL PIN GAGES WITH TWO DECIMAL PLACES (0.01MM STEP)

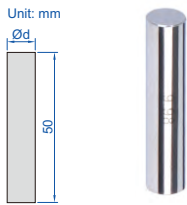

4110-9D98

### Ordering examples:

Diameter	Code
0.21mm	4110-0D21
5.56mm	4110-5D56
16.00mm	4110-16D00

Note : "D" stands for "."

- Meet DIN2269, grade 1
- Diameter range: Ø0.20~Ø20.00mm
- Diameter accuracy: ±1µm
- Made of alloy steel
- Hardness HRC62-65
- Optional accessory: wooden box (code 7340)

Diameter Ød (mm)
0.20, 0.21, 0.22, 0.23, .... 1.00
1.01, 1.02, 1.03, 1.04, .... 2.00
2.01, 2.02, 2.03, 2.04, .... 3.00
3.01, 3.02, 3.03, 3.04, .... 4.00
4.01, 4.02, 4.03, 4.04, .... 5.00
5.01, 5.02, 5.03, 5.04, .... 6.00
6.01, 6.02, 6.03, 6.04, .... 7.00
7.01, 7.02, 7.03, 7.04, .... 8.00
8.01, 8.02, 8.03, 8.04, .... 9.00
9.01, 9.02, 9.03, 9.04, .... 10.00
10.01, 10.02, 10.03, 10.04, .... 11.00
11.01, 11.02, 11.03, 11.04, .... 12.00
12.01, 12.02, 12.03, 12.04, .... 13.00
13.01, 13.02, 13.03, 13.04, .... 14.00
14.01, 14.02, 14.03, 14.04, .... 15.00
15.01, 15.02, 15.03, 15.04, .... 16.00
16.01, 16.02, 16.03, 16.04, .... 17.00
17.01, 17.02, 17.03, 17.04, .... 18.00
18.01, 18.02, 18.03, 18.04, .... 19.00
19.01, 19.02, 19.03, 19.04, .... 20.00

Code
4110-□□□□

## CARBIDE INDIVIDUAL PIN GAGES

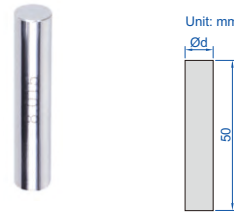

4193-8D015

- Meet DIN2269, grade 1
- Diameter range: Ø0.300~Ø30.000mm with three decimal, for example 0.311mm, 5.562mm, 16.298mm
- Diameter accuracy: ±1µm
- Made of carbide
- Hardness HRA90-90.5
- Optional accessory: wooden box (code 7340)

### Ordering examples:

Diameter	Code
0.311mm	4193-0D311
5.562mm	4193-5D562
16.298mm	4193-16D298

Note: "D" stands for "."

Code	Diameter range Ød (mm)
4193-□□□□*	0.300~30.000

\*Supplied with manufacturer inspection certificate

## CERAMIC INDIVIDUAL PIN GAGES

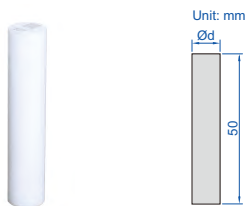

4192-10D000

- Meet DIN2269, grade 1
- Diameter range: Ø1.000~Ø15.000mm
- With three decimal, for example 1.211mm, 5.562mm, 14.955mm
- Diameter accuracy: ±1µm
- Made of ceramic, extremely wear resistance, corrosion resistance and dimensional stability
- Optional accessory: wooden box (code 7340)

### Ordering examples:

Diameter	Code
1.211mm	4192-1D211
5.562mm	4192-5D562
14.955mm	4192-14D955

Note : "D" stands for "."

Code	Diameter range Ød (mm)
4192-□□□□	1.000-15.000

## PIN GAGE HANDLE

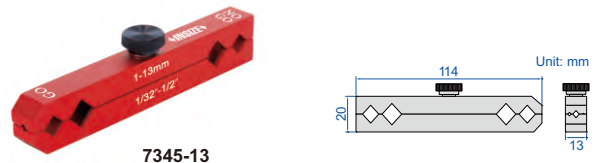

7345-13

application



- Operated without wrench
- Made of aluminum

Code	Applicable pin gage diameter
7345-13	1~13mm

## PIN GAGE HANDLES (OPERATED WITHOUT WRENCH)



7342-M1

application



- Operated without wrench
- Made of aluminum
- Pin gages can be installed

Code	Applicable pin gage diameter	H	L
7342-M0	0.3-1.5mm/0.011-0.049"	10mm	112mm
7342-M1	1.51-6.35mm/0.050-0.250"	24mm	131mm
7342-M2	6.36-12.70mm/0.251-0.500"	32mm	152mm
7342-M3	12.71-15.88mm/0.501-0.625"	37mm	152mm
7342-M4	15.89-19.00mm/0.626-0.750"	37mm	152mm
7342-M5	19.01-21.13mm/0.751-0.832"	40mm	158mm
7342-M6	21.14-23.27mm/0.833-0.916"	40mm	158mm
7342-M7	23.28-25.4mm/0.917-1.000"	40mm	158mm

## SINGLE END PIN GAGE HANDLES (OPERATED WITH WRENCH)

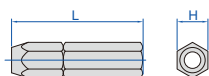
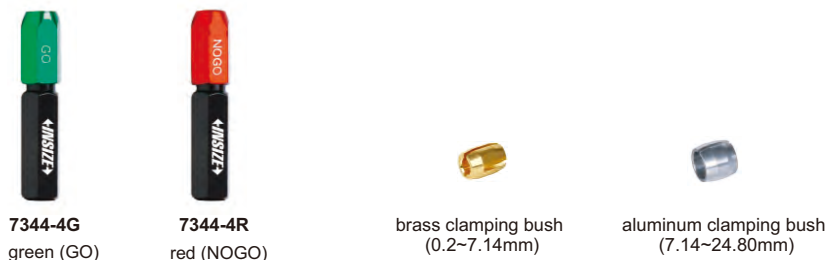

- Wrench is needed to install pins
- Clamping bushes (0.2~7.14mm) are made of brass, clamping bushes (7.14~24.80mm) are made of aluminum

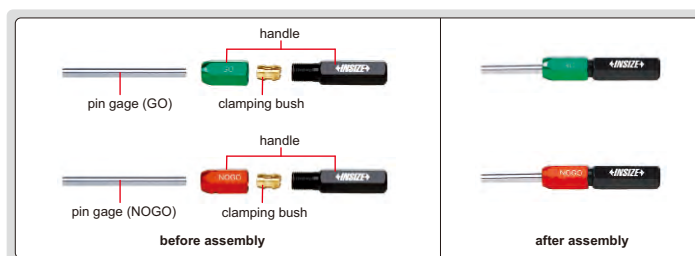

Code		Including		Applicable pin gage diameter	(mm)	
green (GO)	red (NOGO)	handle	clamping bush (mm)		H	L
7344-0G	7344-0R	1 pc	6 pcs (the clamping range are 0.2-0.38, 0.38-0.51, 0.51-0.64, 0.64-0.76, 0.76-0.89, 0.89-1.02)	0.2-1.02mm	7	52
7344-1G	7344-1R	1 pc	7 pcs (the clamping range are 1.02-1.14, 1.14-1.27, 1.27-1.40, 1.40-1.52, 1.52-1.65, 1.65-1.78, 1.78-1.91)	1.02-1.91mm	7	52
7344-2G	7344-2R	1 pc	8 pcs (the clamping range are 1.91-2.08, 2.08-2.26, 2.26-2.44, 2.44-2.62, 2.62-2.79, 2.79-2.97, 2.97-3.15, 3.15-3.33)	1.91-3.33mm	9	68
7344-3G	7344-3R	1 pc	7 pcs (the clamping range are 3.33-3.51, 3.51-3.68, 3.68-3.86, 3.86-4.04, 4.04-4.22, 4.22-4.39, 4.39-4.57)	3.33-4.57mm	9	68
7344-4G	7344-4R	1 pc	6 pcs (the clamping range are 4.57-4.78, 4.78-4.98, 4.98-5.18, 5.18-5.38, 5.38-5.59, 5.59-5.79)	4.57-5.79mm	14	73
7344-5G	7344-5R	1 pc	6 pcs (the clamping range are 5.79-5.99, 5.99-6.20, 6.20-6.40, 6.40-6.63, 6.63-6.88, 6.88-7.14)	5.79-7.14mm	14	73
7344-6G	7344-6R	1 pc	6 pcs (the clamping range are 7.14-7.39, 7.39-7.65, 7.65-7.90, 7.90-8.15, 8.15-8.41, 8.41-8.66)	7.14-8.66mm	19	79
7344-7G	7344-7R	1 pc	6 pcs (the clamping range are 8.66-8.92, 8.92-9.17, 9.17-9.42, 9.42-9.70, 9.70-10.01, 10.01-10.31)	8.66-10.31mm	19	79
7344-8G	7344-8R	1 pc	4 pcs (the clamping range are 10.31-10.67, 10.67-11.05, 11.05-11.43, 11.43-11.81)	10.31-11.81mm	22	93
7344-9G	7344-9R	1 pc	3 pcs (the clamping range are 11.81-12.19, 12.19-12.57, 12.57-12.95)	11.81-12.95mm	22	93
7344-10G	7344-10R	1 pc	4 pcs (the clamping range are 12.95-13.51, 13.51-13.89, 13.89-14.30, 14.30-14.71)	12.95-14.71mm	24	98
7344-11G	7344-11R	1 pc	4 pcs (the clamping range are 14.71-15.09, 15.09-15.49, 15.49-15.88, 15.88-16.13)	14.71-16.13mm	24	98
7344-12G	7344-12R	1 pc	4 pcs (the clamping range are 16.13-16.66, 16.66-17.07, 17.07-17.48, 17.48-17.88)	16.13-17.88mm	27	110
7344-13G	7344-13R	1 pc	4 pcs (the clamping range are 17.88-18.26, 18.26-18.67, 18.67-19.05, 19.05-19.30)	17.88-19.30mm	27	110
7344-15G	7344-15R	1 pc	8 pcs (the clamping range are 19.30-19.84, 19.84-20.62, 20.62-21.41, 21.41-22.23, 22.23-23.03, 23.03-23.80, 23.80-24.59, 24.59-24.80)	19.30-24.80mm	32	118

## PIN GAGE HANDLES (OPERATED WITH WRENCH)



handle



brass clamping bush (0.2~7.14mm)



aluminum clamping bush (7.14~24.80mm)

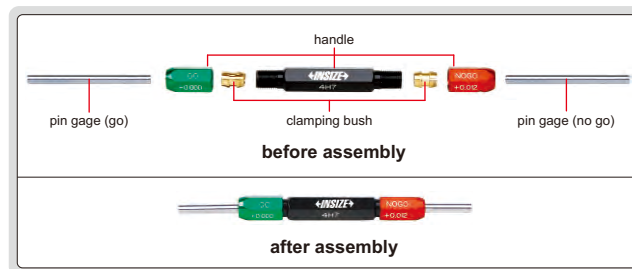

- Wrench is needed to install pins
- Clamping bushes (0.2~7.14mm) are made of brass, clamping bushes (7.14~24.80mm) are made of aluminum

Code	Applicable pin gage diameter	Including		(mm)	
		handle	clamping bush (mm)	H	L
7341-0S	0.2-1.02mm	1 pc	6 pairs (the clamping range are 0.2-0.38, 0.38-0.51, 0.51-0.64, 0.64-0.76, 0.76-0.89, 0.89-1.02)	7	57
7341-1S	1.02-1.91mm	1 pc	7 pairs (the clamping range are 1.02-1.14, 1.14-1.27, 1.27-1.40, 1.40-1.52, 1.52-1.65, 1.65-1.78, 1.78-1.91)	7	57
7341-2S	1.91-3.33mm	1 pc	8 pairs (the clamping range are 1.91-2.08, 2.08-2.26, 2.26-2.44, 2.44-2.62, 2.62-2.79, 2.79-2.97, 2.97-3.15, 3.15-3.33)	9	73
7341-3S	3.33-4.57mm	1 pc	7 pairs (the clamping range are 3.33-3.51, 3.51-3.68, 3.68-3.86, 3.86-4.04, 4.04-4.22, 4.22-4.39, 4.39-4.57)	9	73
7341-4S	4.57-5.79mm	1 pc	6 pairs (the clamping range are 4.57-4.78, 4.78-4.98, 4.98-5.18, 5.18-5.38, 5.38-5.59, 5.59-5.79)	14	79
7341-5S	5.79-7.14mm	1 pc	6 pairs (the clamping range are 5.79-5.99, 5.99-6.20, 6.20-6.40, 6.40-6.63, 6.63-6.88, 6.88-7.14)	14	79
7341-6S	7.14-8.66mm	1 pc	6 pairs (the clamping range are 7.14-7.39, 7.39-7.65, 7.65-7.90, 7.90-8.15, 8.15-8.41, 8.41-8.66)	19	91
7341-7S	8.66-10.31mm	1 pc	6 pairs (the clamping range are 8.66-8.92, 8.9-9.17, 9.17-9.42, 9.42-9.70, 9.70-10.01, 10.01-10.31)	19	91
7341-8S	10.31-11.81mm	1 pc	4 pairs (the clamping range are 10.31-10.67, 10.67-11.05, 11.05-11.43, 11.43-11.81)	22	106
7341-9S	11.81-12.95mm	1 pc	3 pairs (the clamping range are 11.81-12.19, 12.19-12.57, 12.57-12.95)	22	106
7341-10S	12.95-14.71mm	1 pc	4 pairs (the clamping range are 12.95-13.51, 13.51-13.89, 13.89-14.30, 14.30-14.71)	24	115
7341-11S	14.71-16.13mm	1 pc	4 pairs (the clamping range are 14.71-15.09, 15.09-15.49, 15.49-15.88, 15.88-16.13)	24	115
7341-12S	16.13-17.88mm	1 pc	4 pairs (the clamping range are 16.13-16.66, 16.66-17.07, 17.07-17.48, 17.48-17.88)	27	118
7341-13S	17.88-19.30mm	1 pc	4 pairs (the clamping range are 17.88-18.26, 18.26-18.67, 18.67-19.05, 19.05-19.30)	27	118
7341-15S	19.30-24.80mm	1 pc	8 pairs (the clamping range are 19.30-19.84, 19.84-20.62, 20.62-21.41, 21.41-22.23, 22.23-23.03, 23.03-23.80, 23.80-24.59, 24.59-24.80)	32	133

## ADJUSTABLE SNAP GAGES

FAST AND ACCURATE MEASUREMENT OF CYLINDERS

(mm)

Code	Range	L	A	B	E	F	H	Ød
2187-6	0-6mm	74	15	17.5	12.2	27.2	71.5	7
2187-13	6-13mm	85	15	26	12.2	27.2	79.5	12.3
2187-19	13-19mm	93	15	27	12.2	27.2	83	12.3
2187-25	19-25mm	100	15	33.5	12.2	27.2	89.5	12.3
2187-32	25-32mm	111	18	38.5	15.2	35.2	104	15.3
2187-38	32-38mm	117	18	41.5	15.2	35.2	105	15.3
2187-44	38-44mm	123	18	44.5	15.2	35.2	109	15.3
2187-51	44-51mm	130	18	48	15.2	35.2	117	15.3



2187-19

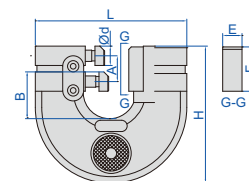

- Used as Go/No-Go gage by setting upper and lower limits
- Flatness of anvil: 1.5µm
- Parallelism of measuring faces:
  - range 0-32mm: 3µm
  - range 32-89mm: 4µm
  - range 89-300mm: 5µm

# SETTING RINGS



CAN SUPPLY CUSTOM SETTING RINGS FROM Ø1.50MM TO Ø400.00MM, FOR EXAMPLE, Ø17.08MM

- For zero setting of inside micrometers, three points internal micrometers and bore gages
- The size marked on the setting ring is checked at the direction of the marking line
- Size difference (difference between the ordered size and the size marked on the setting ring when supplied):  
For example, the ordered size is Ø10.12mm, the size marked on the setting ring when supplied may be Ø10.130mm
- Meet DIN2250-1:2008

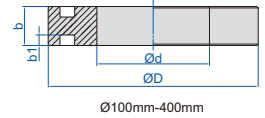
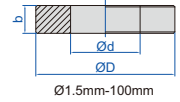

Diameter d <sup>**</sup>	b	ØD	Size difference	Roundness and cylindricity
Ø1.5-2.5	4mm	22mm	±10.0µm	0.3µm
Ø2.5-3	5mm	22mm	±10.0µm	0.3µm
Ø3-5	5mm	22mm	±10.0µm	0.4µm
Ø5-10	8mm	32mm	±10.0µm	0.4µm
Ø10-15	10mm	38mm	±10.0µm	0.5µm
Ø15-18	12mm	45mm	±10.0µm	0.5µm
Ø18-20	12mm	45mm	±10.0µm	0.6µm
Ø20-25	14mm	53mm	±10.0µm	0.6µm
Ø25-30	16mm	63mm	±10.0µm	0.6µm
Ø30-32	16mm	63mm	±10.0µm	0.7µm
Ø32-40	18mm	71mm	±10.0µm	0.7µm
Ø40-50	20mm	85mm	±10.0µm	0.7µm
Ø50-60	20mm	100mm	±10.0µm	0.8µm
Ø60-70	24mm	112mm	±10.0µm	0.8µm
Ø70-80	24mm	125mm	±10.0µm	0.8µm
Ø80-90	24mm	140mm	±10.0µm	1.0µm
Ø90-100	24mm	160mm	±10.0µm	1.0µm

Diameter d <sup>**</sup>	b	b1	ØD	Size difference	Roundness and cylindricity
Ø100-110	30mm	8mm	164mm	±10.0µm	1.0µm
Ø110-130	34mm	10mm	192mm	±10.0µm	1.0µm
Ø130-150	34mm	10mm	220mm	±10.0µm	1.2µm
Ø150-170	36mm	10mm	248mm	±10.0µm	1.5µm
Ø170-190	36mm	10mm	276mm	±10.0µm	1.5µm
Ø190-210	38mm	10mm	300mm	±10.0µm	1.5µm
Ø210-230	38mm	10mm	324mm	±10.0µm	2.5µm
Ø230-250	40mm	12mm	350mm	±10.0µm	2.5µm
Ø250-270	40mm	12mm	375mm	±10.0µm	3.0µm
Ø270-290	42mm	12mm	400mm	±10.0µm	3.0µm
Ø290-300	42mm	12mm	425mm	±10.0µm	3.0µm
Ø300-320	42mm	12mm	430mm	±10.0µm	4.0µm
Ø320-330	42mm	12mm	440mm	±10.0µm	4.0µm
Ø330-340	42mm	12mm	450mm	±10.0µm	4.0µm
Ø340-350	42mm	12mm	460mm	±10.0µm	4.0µm
Ø350-360	42mm	12mm	470mm	±10.0µm	4.0µm
Ø360-370	42mm	12mm	480mm	±10.0µm	4.0µm
Ø370-380	42mm	12mm	490mm	±10.0µm	4.0µm
Ø380-390	42mm	12mm	500mm	±10.0µm	4.0µm
Ø390-400	42mm	12mm	510mm	±10.0µm	4.0µm

\*\* For example Ø3-5mm means Ø3mm<diameter d≤Ø5mm

Code	Size
6312-1D5*	Ø1.5mm
6312-2*	Ø2mm
6312-2D5*	Ø2.5mm
6312-3*	Ø3mm
6312-3D5*	Ø3.5mm
6312-4*	Ø4mm
6312-4D5*	Ø4.5mm
6312-5*	Ø5mm
6312-5D5*	Ø5.5mm
6312-6*	Ø6mm
6312-6D5*	Ø6.5mm
6312-7*	Ø7mm
6312-7D5*	Ø7.5mm
6312-8*	Ø8mm
6312-8D5*	Ø8.5mm
6312-9*	Ø9mm
6312-9D5*	Ø9.5mm
6312-10*	Ø10mm
6312-10D5*	Ø10.5mm
6312-11*	Ø11mm
6312-11D5*	Ø11.5mm
6312-12*	Ø12mm
6312-12D5*	Ø12.5mm
6312-13*	Ø13mm
6312-13D5*	Ø13.5mm
6312-14*	Ø14mm
6312-14D5*	Ø14.5mm

Code	Size
6312-15*	Ø15mm
6312-15D5*	Ø15.5mm
6312-16*	Ø16mm
6312-16D5*	Ø16.5mm
6312-17*	Ø17mm
6312-17D5*	Ø17.5mm
6312-18*	Ø18mm
6312-18D5*	Ø18.5mm
6312-19*	Ø19mm
6312-19D5*	Ø19.5mm
6312-20*	Ø20mm
6312-20D5*	Ø20.5mm
6312-21*	Ø21mm
6312-21D5*	Ø21.5mm
6312-22*	Ø22mm
6312-22D5*	Ø22.5mm
6312-23*	Ø23mm
6312-23D5*	Ø23.5mm
6312-24*	Ø24mm
6312-24D5*	Ø24.5mm
6312-25*	Ø25mm
6312-25D5*	Ø25.5mm
6312-26*	Ø26mm
6312-26D5*	Ø26.5mm
6312-27*	Ø27mm
6312-27D5*	Ø27.5mm
6312-28*	Ø28mm

Code	Size
6312-28D5*	Ø28.5mm
6312-29*	Ø29mm
6312-29D5*	Ø29.5mm
6312-30*	Ø30mm
6312-31*	Ø31mm
6312-32*	Ø32mm
6312-33*	Ø33mm
6312-34*	Ø34mm
6312-35*	Ø35mm
6312-36*	Ø36mm
6312-37*	Ø37mm
6312-38*	Ø38mm
6312-39*	Ø39mm
6312-40*	Ø40mm
6312-41*	Ø41mm
6312-42*	Ø42mm
6312-43*	Ø43mm
6312-44*	Ø44mm
6312-45*	Ø45mm
6312-46*	Ø46mm
6312-47*	Ø47mm
6312-48*	Ø48mm
6312-49*	Ø49mm
6312-50*	Ø50mm
6312-55*	Ø55mm
6312-60*	Ø60mm
6312-62*	Ø62mm

Code	Size
6312-65*	Ø65mm
6312-70*	Ø70mm
6312-75*	Ø75mm
6312-80*	Ø80mm
6312-85*	Ø85mm
6312-87*	Ø87mm
6312-90*	Ø90mm
6312-95*	Ø95mm
6312-100*	Ø100mm
6312-112D5*	Ø112.5mm
6312-125*	Ø125mm
6312-137D5*	Ø137.5mm
6312-150*	Ø150mm
6312-162D5*	Ø162.5mm
6312-175*	Ø175mm
6312-187D5*	Ø187.5mm
6312-200*	Ø200mm
6312-212D5*	Ø212.5mm
6312-225*	Ø225mm
6312-237D5*	Ø237.5mm
6312-250*	Ø250mm
6312-262D5*	Ø262.5mm
6312-275*	Ø275mm
6312-287D5*	Ø287.5mm
6312-300*	Ø300mm
6312-350*	Ø350mm
6312-400*	Ø400mm

\* Supplied with manufacturer inspection certificate

## CERAMIC MEASURING BALLS



4190-40D000

- Zirconia material, high strength and hardness, extremely wear resistance and corrosion resistance, good insulation, antistatic and magnetic resistance
- Mirror surface without holes
- Supplied with manufacturer inspection certificate

### Individual

Code	Diameter	Accuracy	Roundness
4190-1D000	1.000mm	±2µm	0.5µm
4190-1D200	1.200mm	±2µm	0.5µm
4190-1D300	1.300mm	±2µm	0.5µm
4190-1D340	1.340mm	±2µm	0.5µm
4190-1D500	1.500mm	±2µm	0.5µm
4190-1D588	1.588mm (1/16")	±2µm	0.5µm
4190-1D750	1.750mm	±2µm	0.5µm
4190-2D000	2.000mm	±2µm	0.5µm
4190-2D381	2.381mm (3/32")	±2µm	0.5µm
4190-2D500	2.500mm	±2µm	0.5µm
4190-2D778	2.778mm (7/64")	±2µm	0.5µm
4190-3D000	3.000mm	±2µm	0.5µm
4190-3D175	3.175mm (1/8")	±2µm	0.5µm
4190-3D500	3.500mm	±2µm	0.5µm
4190-3D969	3.969mm (5/32")	±2µm	0.5µm
4190-4D000	4.000mm	±2µm	0.5µm
4190-4D500	4.500mm	±2µm	0.5µm
4190-4D763	4.763mm (3/16")	±2µm	0.5µm
4190-5D000	5.000mm	±2µm	0.5µm
4190-5D556	5.556mm (7/32")	±2µm	0.5µm
4190-5D953	5.953mm (15/64")	±2µm	0.5µm
4190-6D000	6.000mm	±2µm	0.5µm
4190-6D350	6.350mm (1/4")	±2µm	0.5µm
4190-6D500	6.500mm	±2µm	0.5µm
4190-6D747	6.747mm (17/64")	±2µm	0.5µm
4190-7D000	7.000mm	±2µm	0.5µm
4190-7D144	7.144mm (9/32")	±2µm	0.5µm
4190-7D500	7.500mm	±2µm	0.5µm
4190-7D938	7.938mm (5/16")	±2µm	0.5µm
4190-8D000	8.000mm	±2µm	0.5µm
4190-8D731	8.731mm (11/32")	±2µm	0.5µm

### Individual

Code	Diameter	Accuracy	Roundness
4190-9D525	9.525mm (3/8")	±2µm	0.5µm
4190-10D000	10.000mm	±2µm	0.5µm
4190-10D318	10.318mm (13/32")	±2µm	0.5µm
4190-11D000	11.000mm	±2µm	0.5µm
4190-11D113	11.113mm (7/16")	±2µm	0.5µm
4190-11D509	11.509mm (29/64")	±2µm	0.5µm
4190-11D906	11.906mm (15/32")	±2µm	0.5µm
4190-12D000	12.000mm	±2µm	0.5µm
4190-12D303	12.303mm (31/64")	±2µm	0.5µm
4190-12D700	12.700mm (1/2")	±2µm	0.5µm
4190-13D000	13.000mm	±2µm	0.6µm
4190-13D494	13.494mm (17/32")	±2µm	0.6µm
4190-14D000	14.000mm	±2µm	0.6µm
4190-14D288	14.288mm (9/16")	±2µm	0.6µm
4190-15D000	15.000mm	±2µm	0.6µm
4190-15D081	15.081mm (19/32")	±2.5µm	0.6µm
4190-15D875	15.875mm (5/8 ")	±2.5µm	0.6µm
4190-16D000	16.000mm	±2.5µm	0.6µm
4190-16D669	16.669mm (21/32")	±2.5µm	0.6µm
4190-17D462	17.462mm (11/16")	±2.5µm	0.6µm
4190-18D000	18.000mm	±2.5µm	0.6µm
4190-18D256	18.256mm (23/32")	±2.5µm	0.6µm
4190-19D050	19.050mm (3/4")	±2.5µm	0.6µm
4190-19D844	19.844mm (25/32")	±2.5µm	0.6µm
4190-20D000	20.000mm	±2.5µm	0.6µm
4190-22D000	22.000mm	±2.5µm	1µm
4190-22D225	22.225mm (7/8")	±2.5µm	1µm
4190-23D812	23.812mm (15/16")	±2.5µm	1µm
4190-25D000	25.000mm	±2.5µm	1µm
4190-40D000	40.000mm	±2.5µm	1.5µm

### Set (25 pairs)

Code	Ceramic balls included (one pair per size)
4190-S25	1, 1.5, 2, 2.5, 3, 3.5, 4, 4.5, 5, 6, 6.5, 7, 7.5, 8, 10, 11, 12, 13, 14, 15, 16, 18, 20, 22, 25mm

## PLAIN PLUG GAGES

- Supplied with Go and No-Go gages together
- Class H7
- Hardness HRC 60±2
- Standard DIN7150-2

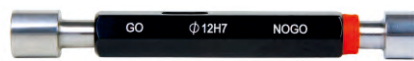

4124-12

**CUSTOM-MADE**  
 OTHER CLASSES ARE AVAILABLE, SUCH AS H8, H9  
 OTHER DIAMETERS ARE AVAILABLE, SUCH AS 19.003mm  
 OTHER LENGTHS ARE AVAILABLE, SUCH AS 70mm

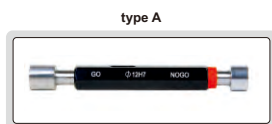

type A



Type A



type B

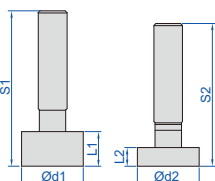

Type B

Size tolerance of H7 (mm)

Diameter Ød	Type	Size tolerance of Go gage (µm)	Size tolerance of No-Go gage (µm)	L1	L2	L	S1, S2
≥2, ≤3	A	+0.5 / +2.5	+9 / +11	6.5	4.5	62	-
>3, ≤6	A	+0.75 / +3.25	+10.75 / +13.25	8	6	74	-
>6, ≤10	A	+0.75 / +3.25	+13.75 / +16.25	10	7	87	-
>10, ≤14	A	+1 / +4	+16.5 / +19.5	12	8	99	-
>14, ≤18	A	+1 / +4	+16.5 / +19.5	14	10	114	-
>18, ≤24	A	+1 / +5	+19 / +23	16	12	132	-
>24, ≤30	A	+1 / +5	+19 / +23	18	14	136	-
>30, ≤40	A	+1.5 / +5.5	+23 / +27	20	15	155	-
>40, ≤50	A	+1.5 / +5.5	+23 / +27	25	18	169	-
>50, ≤65	B	+1.5 / +6.5	+27.5 / +32.5	30	18	-	164, 152
>65, ≤80	B	+1.5 / +6.5	+27.5 / +32.5	35	25	-	169, 159
>80, ≤100	B	+2 / +8	+32 / +38	35	25	-	169, 159

Code	Diameter	Type	Code	Diameter	Type	Code	Diameter	Type	Code	Diameter	Type	Code	Diameter	Type
4124-2	2mm	A	4124-13	13mm	A	4124-24	24mm	A	4124-38	38mm	A	4124-52	52mm	B
4124-3	3mm	A	4124-14	14mm	A	4124-25	25mm	A	4124-39	39mm	A	4124-55	55mm	B
4124-4	4mm	A	4124-15	15mm	A	4124-26	26mm	A	4124-40	40mm	A	4124-60	60mm	B
4124-5	5mm	A	4124-16	16mm	A	4124-28	28mm	A	4124-41	41mm	A	4124-65	65mm	B
4124-6	6mm	A	4124-17	17mm	A	4124-29	29mm	A	4124-42	42mm	A	4124-70	70mm	B
4124-7	7mm	A	4124-18	18mm	A	4124-30	30mm	A	4124-44	44mm	A	4124-75	75mm	B
4124-8	8mm	A	4124-19	19mm	A	4124-31	31mm	A	4124-45	45mm	A	4124-80	80mm	B
4124-9	9mm	A	4124-20	20mm	A	4124-32	32mm	A	4124-46	46mm	A	4124-85	85mm	B
4124-10	10mm	A	4124-21	21mm	A	4124-34	34mm	A	4124-47	47mm	A	4124-100	100mm	B
4124-11	11mm	A	4124-22	22mm	A	4124-35	35mm	A	4124-49	49mm	A			
4124-12	12mm	A	4124-23	23mm	A	4124-36	36mm	A	4124-50	50mm	A			

## THREAD DEPTH GAGES

**INSIZE PLUS**  
 MADE IN EUROPE

**INSPECTION CERTIFICATE**



- Supplied with GO and NO-GO gages together
- Check GO and NO-GO while measuring the depth of holes
- The GO gage can be replaced after wear
- Optional accessory: zero block (code 4668-SETTER), removal tool (code 4668-TOOL)



4666-6

Metric thread (without vernier reading, graduation: 0.5mm, accuracy: ±0.25mm)

Code	Size (mm)	Depth range
4666-2*	M2x0.4-6H	0-8mm
4666-2D5*	M2.5x0.45-6H	0-10mm
4666-3*	M3x0.5-6H	0-12mm
4666-3D5*	M3.5x0.6-6H	0-14mm
4666-4*	M4x0.7-6H	0-16mm
4666-5*	M5x0.8-6H	0-20mm
4666-6*	M6x1-6H	0-24mm
4666-7*	M7x1-6H	0-28mm
4666-8*	M8x1.25-6H	0-32mm
4666-10*	M10x1.5-6H	0-40mm
4666-12*	M12x1.75-6H	0-48mm
4666-14*	M14x2-6H	0-56mm
4666-16*	M16x2-6H	0-64mm
4666-18*	M18x2.5-6H	0-72mm
4666-20*	M20x2.5-6H	0-80mm
4666-22*	M22x2.5-6H	0-80mm
4666-24*	M24x3-6H	0-80mm
4666-27*	M27x3-6H	0-80mm
4666-30*	M30x3.5-6H	0-80mm

Metric thread (with vernier reading, graduation: 0.1mm, accuracy: ±0.1mm)

Code	Size (mm)	Depth range
4666-2A*	M2x0.4-6H	0-8mm
4666-2D5A*	M2.5x0.45-6H	0-10mm
4666-3A*	M3x0.5-6H	0-12mm
4666-3D5A*	M3.5x0.6-6H	0-14mm
4666-4A*	M4x0.7-6H	0-16mm
4666-5A*	M5x0.8-6H	0-20mm
4666-6A*	M6x1-6H	0-24mm
4666-7A*	M7x1-6H	0-28mm
4666-8A*	M8x1.25-6H	0-32mm
4666-10A*	M10x1.5-6H	0-40mm
4666-12A*	M12x1.75-6H	0-48mm
4666-14A*	M14x2-6H	0-56mm
4666-16A*	M16x2-6H	0-64mm
4666-18A*	M18x2.5-6H	0-72mm
4666-20A*	M20x2.5-6H	0-80mm
4666-22A*	M22x2.5-6H	0-80mm
4666-24A*	M24x3-6H	0-80mm
4666-27A*	M27x3-6H	0-80mm
4666-30A*	M30x3.5-6H	0-80mm

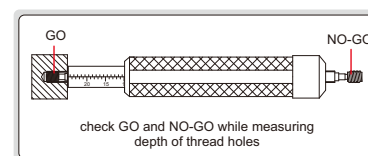
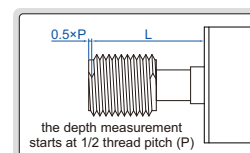

\* Supplied with manufacturer inspection certificate

## METRIC THREAD PLUG GAGES



WARNING: LIFE TIME IS LIMITED,  
CAN BE USED ABOUT 2000 TIMES



- Supplied with Go and No-Go gages together
- Standard ISO1502
- Supplied with manufacturer inspection certificate

4130-10

### Individual

Size (mm)		Code		
Nominal diameter	Pitch	Class 6H	Class 6G	Class 4H
M0.8	0.2	4130-D8	4130-D8G	–
M0.9	0.225	4130-D9	–	–
M1	0.25	4130-1	–	4130-1H
M1.2	0.25	4130-1D2	4130-1D2G	4130-1D2H
M1.4	0.3	4130-1D4	–	4130-1D4H
M1.6	0.35	4130-1D6	4130-1D6G	4130-1D6H
M1.7	0.35	4130-1D7	–	–
M1.8	0.35	4130-1D8	4130-1D8G	4130-1D8H
M2	0.4	4130-2	4130-2G	4130-2H
M2.2	0.45	4130-2D2	4130-2D2G	4130-2D2H
M2.3	0.4	4130-2D3	4130-2D3G	–
M2.5	0.45	4130-2D5	4130-2D5G	4130-2D5H
M2.6	0.45	4130-2D6	4130-2D6G	–
M3	0.5	4130-3	4130-3G	4130-3H
M3.5	0.6	4130-3D5	4130-3D5G	4130-3D5H
M4	0.7	4130-4	4130-4G	4130-4H
M4.5	0.75	4130-4D5	4130-4D5G	4130-4D5H
M5	0.8	4130-5	4130-5G	4130-5H
M6	1	4130-6	4130-6G	4130-6H
M7	1	4130-7	4130-7G	4130-7H
M8	1.25	4130-8	4130-8G	4130-8H
M9	1.25	4130-9	4130-9G	4130-9H
M10	1.5	4130-10	4130-10G	4130-10H
M11	1.5	4130-11	4130-11G	4130-11H
M12	1.75	4130-12	4130-12G	4130-12H
M14	2	4130-14	4130-14G	4130-14H
M16	2	4130-16	4130-16G	4130-16H
M18	2.5	4130-18	4130-18G	4130-18H
M20	2.5	4130-20	4130-20G	4130-20H
M22	2.5	4130-22	4130-22G	–
M24	3	4130-24	4130-24G	–
M27	3	4130-27	4130-27G	–
M30	3.5	4130-30	4130-30G	–
M33	3.5	4130-33	4130-33G	–
M36	4	4130-36	4130-36G	4130-36H
M39	4	4130-39	4130-39G	–
M42	4.5	4130-42	–	–
M45	4.5	4130-45	–	–
M48	5	4130-48	–	–
M52	5	4130-52	4130-52G	–
M56	5.5	4130-56	–	–
M60	5.5	4130-60	–	–

### Set (class 6H)

Code	Thread plug gages included (mm)
4130-S7	M3x0.5 (4130-3), M4x0.7 (4130-4), M5x0.8 (4130-5), M6x1 (4130-6), M8x1.25 (4130-8), M10x1.5 (4130-10), M12x1.75 (4130-12)

# METRIC FINE THREAD PLUG GAGES

- Supplied with Go and No-Go gages together
- Standard ISO1502
- Supplied with manufacturer inspection certificate



4139-20G



WARNING: LIFE TIME IS LIMITED, CAN BE USED ABOUT 2000 TIMES

Code example:  
"-1A" stands for "4139-1A"

Code (4139)					Code (4139)					Code (4139)				
Nominal diameter	Pitch	Class 6H	Class 6G	Class 4H	Nominal diameter	Pitch	Class 6H	Class 6G	Class 4H	Nominal diameter	Pitch	Class 6H	Class 6G	Class 4H
M1	0.2	-1A	-	-	M15	0.5	-15G	-15GG	-					
M1.2	0.2	-1D2A	-	-		1	-15P	-15PG	-15PH					
M1.4	0.2	-1D4A	-	-		1.5	-15R	-15RG	-15RH					
M1.6	0.2	-1D6A	-1D6AG	-	M16	0.5	-16G	-16GG	-					
M1.8	0.2	-1D8A	-	-		1	-16P	-16PG	-16PH					
M2	0.2	-2A	-2AG	-		1.25	-16Q	-	-					
	0.25	-2B	-2BG	-2BH	1.5	-16R	-16RG	-16RH						
M2.5	0.2	-2D5A	-	-	M17	0.5	-17G	-17GG	-					
	0.25	-2D5B	-	-2D5BH		1	-17P	-17PG	-17PH					
	0.35	-2D5D	-	-		1.5	-17R	-17RG	-17RH					
M3	0.25	-3B	-	-3BH	M18	0.5	-18G	-18GG	-					
	0.35	-3D	-	-3DH		1	-18P	-18PG	-18PH					
M3.5	0.25	-3D5B	-	-		1.25	-18Q	-	-					
	0.35	-3D5D	-	-3D5DH		1.5	-18R	-18RG	-18RH					
0.5	-3D5G	-	-	2		-18T	-18TG	-18TH						
M4	0.25	-4B	-	-	M19	0.5	-19G	-	-					
	0.35	-4D	-	-4DH		1	-19P	-19PG	-19PH					
	0.5	-4G	-4GG	-4GH		1.5	-19R	-	-19RH					
M4.5	0.35	-4D5D	-	-	M20	0.5	-20G	-20GG	-20GH					
	0.5	-4D5G	-4D5GG	-		1	-20P	-20PG	-20PH					
M5	0.25	-5B	-	-		1.25	-20Q	-	-					
	0.35	-5D	-	-		1.5	-20R	-20RG	-20RH					
	0.5	-5G	-5GG	-5GH		2	-20T	-20TG	-20TH					
M5.5	0.5	-5D5G	-	-	M21	0.5	-21G	-	-					
M6	0.25	-6B	-6BG	-		1	-21P	-21PG	-21PH					
	0.35	-6D	-	-	1.5	-21R	-	-						
M6.5	0.5	-6G	-6GG	-6GH	M22	0.5	-22G	-	-					
	0.5	-6D5G	-	-		1	-22P	-22PG	-22PH					
M7	0.35	-7D	-	-		1.25	-22Q	-	-					
	0.5	-7G	-7GG	-		1.5	-22R	-22RG	-22RH					
M7.5	0.5	-7D5G	-	-		2	-22T	-22TG	-22TH					
M8	0.35	-8D	-	-	M23	0.5	-23G	-	-					
	0.5	-8G	-8GG	-8GH		1	-23P	-23PG	-23PH					
	1	-8P	-8PG	-8PH		M24	0.5	-24G	-	-				
M8.5	0.5	-8D5G	-	-	1		-24P	-24PG	-24PH					
	0.35	-9D	-	-	1.25		-24Q	-	-					
M9	0.5	-9G	-9GG	-	1.5		-24R	-24RG	-24RH					
	0.75	-9L	-9LG	-9LH	2		-24T	-24TG	-24TH					
	1	-9P	-9PG	-9PH	M25	0.5	-25G	-	-					
M10	0.35	-10D	-	-		1	-25P	-25PG	-25PH					
	0.5	-10G	-10GG	-10GH		1.5	-25R	-25RG	-25RH					
	1	-10P	-10PG	-10PH	2	-25T	-25TG	-25TH						
M11	1.25	-10Q	-10QG	-10QH	M26	0.5	-26G	-	-					
	0.5	-11G	-11GG	-11GH		1	-26P	-26PG	-26PH					
	1	-11P	-11PG	-11PH		1.5	-26R	-26RG	-26RH					
M12	2	-26T	-26TG	-26TH	M27	0.5	-27G	-	-					
	0.5	-12G	-12GG	-12GH		1	-27P	-27PG	-27PH					
	1	-12P	-12PG	-12PH		1.5	-27R	-27RG	-27RH					
1.25	-12Q	-12QG	-12QH	2		-27T	-27TG	-27TH						
1.5	-12R	-12RG	-12RH	M28		0.5	-28G	-	-					
M13	0.5	-13G	-		-13GH	1	-28P	-28PG	-28PH					
	1	-13P	-13PG		-13PH	1.5	-28R	-28RG	-28RH					
	1.5	-13R	-	-	2	-28T	-28TG	-28TH						
M14	0.5	-14G	-14GG	-14GH	M29	0.5	-29G	-	-					
	1	-14P	-14PG	-14PH		0.75	-29L	-	-					
	1.25	-14Q	-14QG	-14QH										
1.5	-14R	-14RG	-14RH											
M29	1	-45P	-	-	M30	1	-30P	-30PG	-30PH					
	1.5	-45R	-45RG	-		0.5	-30G	-	-					
	2	-45T	-	-		0.75	-30L	-	-					
M31	0.5	-31G	-	-	M31	1	-30P	-30PG	-30PH					
	0.75	-31L	-	-		1.5	-30R	-30RG	-30RH					
	1	-31P	-	-		2	-30T	-30TG	-30TH					
M32	0.75	-32G	-	-	M32	3	-30V	-	-					
	1	-32P	-32PG	-32PH		0.5	-31G	-	-					
	1.5	-32R	-32RG	-32RH		0.75	-31L	-	-					
M33	2	-32T	-32TG	-32TH	M33	1	-32P	-32PG	-32PH					
	0.5	-33G	-	-		1.5	-32R	-32RG	-32RH					
	0.75	-33L	-	-		2	-32T	-32TG	-32TH					
M34	1	-33P	-33PG	-33PH	M34	0.5	-33G	-	-					
	1.5	-33R	-33RG	-33RH		0.75	-33L	-	-					
	2	-33T	-33TG	-33TH		1	-33P	-33PG	-33PH					
M35	3	-33V	-	-	M35	1.5	-33R	-33RG	-33RH					
	0.75	-34L	-	-		2	-33T	-33TG	-33TH					
	1	-34P	-34PG	-34PH		M36	2	-33V	-	-				
1.5	-34R	-34RG	-34RH	0.75	-34L		-	-						
2	-34T	-	-	1	-34P		-34PG	-34PH						
M36	0.75	-35L	-	-	M36	1.5	-34R	-34RG	-34RH					
	1	-35P	-35PG	-35PH		2	-34T	-	-					
	1.5	-35R	-35RG	-35RH		M37	0.75	-35L	-	-				
2	-35T	-	-	1	-35P		-35PG	-35PH						
M37	0.75	-36L	-	-	M37		1.5	-35R	-35RG	-35RH				
	1	-36P	-36PG	-36PH		2	-35T	-	-					
	1.5	-36R	-36RG	-36RH		M38	0.75	-36L	-	-				
2	-36T	-36TG	-36TH	1	-36P		-36PG	-36PH						
3	-36V	-	-	1.5	-36R		-36RG	-36RH						
M38	0.75	-37L	-	-	M38	2	-36T	-36TG	-36TH					
	1	-38P	-38PG	-38PH		M39	3	-36V	-	-				
	1.5	-38R	-38RG	-38RH			0.75	-37L	-	-				
2	-38T	-38TG	-38TH	M39	1		-38P	-38PG	-38PH					
0.75	-39L	-	-		1.5	-38R	-38RG	-38RH						
1	-39P	-	-		2	-38T	-38TG	-38TH						
M39	1.5	-39R	-	-	M40	2	-39T	-39TG	-39TH					
	2	-39T	-39TG	-39TH		3	-39V	-	-					
	3	-39V	-	-		M42	0.75	-40L	-	-				
M40	0.75	-40L	-	-	1		-40P	-40PG	-40PH					
	1	-40P	-40PG	-40PH	1.5		-40R	-40RG	-40RH					
	1.5	-40R	-40RG	-40RH	2	-40T	-40TG	-40TH						
M41	2	-40T	-40TG	-40TH	M41	3	-40V	-	-					
	1	-42P	-	-		M42	1	-42P	-	-				
	1.5	-42R	-42RG	-			2	-42T	-	-				
2	-42T	-	-	3	-42V		-42VG	-						
M42	3	-42V	-42VG	-	M43	1	-45P	-	-					
	1	-45P	-	-		M45	1.5	-45R	-45RG	-				
	1.5	-45R	-45RG	-			2	-45T	-	-				
M45	2	-45T	-	-										

To be continued



Continued from previous page

METRIC FINE THREAD PLUG GAGES

Code (4139)					Code (4139)					Code (4139)				
Nominal diameter	Pitch	Class 6H	Class 6G	Class 4H	Nominal diameter	Pitch	Class 6H	Class 6G	Class 4H	Nominal diameter	Pitch	Class 6H	Class 6G	Class 4H
M45	3	-45V	-	-	M52	1.5	-52R	-	-	M56	3	-56V	-	-
	1	-48P	-	-		2	-52T	-	-		4	-56X	-	-
M48	1.5	-48R	-	-		3	-52V	-	-	M58	1.5	-58R	-	-
	2	-48T	-	-	M55	4	-52X	-	-		3	-58V	-	-
	3	-48V	-	-		1.5	-55R	-	-	M60	1	-60P	-	-
M50	1	-	-50PG	-	M56	2	-55T	-55TG	-		1.5	-60R	-	-
	1.5	-50R	-	-		1	-56P	-	-		2	-60T	-	-
M52	2	-50T	-	-	1.5	-56R	-	-	3		-60V	-	-	
	1	-52P	-	-	2	-56T	-	-	4	-60X	-	-		

METRIC THREAD RING GAGES

- Standard ISO1502
- Supplied with manufacturer inspection certificate



4120-16



4120-16N

WARNING: LIFE TIME IS LIMITED, CAN BE USED ABOUT 2000 TIMES



Individual

Size (mm)		Code					
Nominal diameter	Pitch	Class 6g		Class 6e		Class 6h	
		GO	NOGO	GO	NOGO	GO	NOGO
M2	0.4	4120-2	4120-2N	4120-2E	4120-2EN	4120-2H	4120-2HN
M2.2	0.45	4120-2D2	4120-2D2N	4120-2D2E	4120-2D2EN	4120-2D2H	4120-2D2HN
M2.3	0.4	4120-2D3	4120-2D3N	-	-	-	-
M2.5	0.45	4120-2D5	4120-2D5N	4120-2D5E	4120-2D5EN	4120-2D5H	4120-2D5HN
M2.6	0.45	4120-2D6	4120-2D6N	-	-	-	-
M3	0.5	4120-3	4120-3N	4120-3E	4120-3EN	4120-3H	4120-3HN
M3.5	0.6	4120-3D5	4120-3D5N	4120-3D5E	4120-3D5EN	4120-3D5H	4120-3D5HN
M4	0.7	4120-4	4120-4N	4120-4E	4120-4EN	4120-4H	4120-4HN
M4.5	0.75	4120-4D5	4120-4D5N	4120-4D5E	4120-4D5EN	4120-4D5H	4120-4D5HN
M5	0.8	4120-5	4120-5N	4120-5E	4120-5EN	4120-5H	4120-5HN
M6	1	4120-6	4120-6N	4120-6E	4120-6EN	4120-6H	4120-6HN
M7	1	4120-7	4120-7N	4120-7E	4120-7EN	4120-7H	4120-7HN
M8	1.25	4120-8	4120-8N	4120-8E	4120-8EN	4120-8H	4120-8HN
M9	1.25	4120-9	4120-9N	4120-9E	4120-9EN	4120-9H	4120-9HN
M10	1.5	4120-10	4120-10N	4120-10E	4120-10EN	4120-10H	4120-10HN
M11	1.5	4120-11	4120-11N	4120-11E	4120-11EN	4120-11H	4120-11HN
M12	1.75	4120-12	4120-12N	4120-12E	4120-12EN	4120-12H	4120-12HN
M14	2	4120-14	4120-14N	4120-14E	4120-14EN	4120-14H	4120-14HN
M16	2	4120-16	4120-16N	4120-16E	4120-16EN	4120-16H	4120-16HN
M18	2.5	4120-18	4120-18N	4120-18E	4120-18EN	4120-18H	4120-18HN
M20	2.5	4120-20	4120-20N	4120-20E	4120-20EN	4120-20H	4120-20HN
M22	2.5	4120-22	4120-22N	4120-22E	4120-22EN	4120-22H	4120-22HN
M24	3	4120-24	4120-24N	4120-24E	4120-24EN	4120-24H	4120-24HN
M27	3	4120-27	4120-27N	4120-27E	4120-27EN	4120-27H	4120-27HN
M30	3.5	4120-30	4120-30N	4120-30E	4120-30EN	4120-30H	4120-30HN
M33	3.5	4120-33	4120-33N	4120-33E	4120-33EN	4120-33H	4120-33HN
M36	4	4120-36	4120-36N	4120-36E	4120-36EN	4120-36H	4120-36HN
M39	4	4120-39	4120-39N	4120-39E	4120-39EN	4120-39H	4120-39HN
M42	4.5	4120-42	4120-42N	-	-	4120-42H	4120-42HN
M45	4.5	4120-45	4120-45N	-	-	4120-45H	4120-45HN
M48	5	4120-48	4120-48N	-	-	4120-48H	4120-48HN
M52	5	4120-52	4120-52N	-	-	4120-52H	4120-52HN
M56	5.5	4120-56	4120-56N	-	-	-	-
M60	5.5	4120-60	4120-60N	-	-	-	-

Go ring gage set (class 6g)

Code	Thread ring gages included
4120-S7	M3x0.5 (4120-3), M4x0.7 (4120-4), M5x0.8 (4120-5), M6x1 (4120-6), M8x1.25 (4120-8), M10x1.5 (4120-10), M12x1.75 (4120-12)

No Go ring gage set (class 6g)

Code	Thread ring gages included
4120-S7N	M3x0.5 (4120-3N), M4x0.7 (4120-4N), M5x0.8 (4120-5N), M6x1 (4120-6N), M8x1.25 (4120-8N), M10x1.5 (4120-10N), M12x1.75 (4120-12N)

# METRIC FINE THREAD RING GAGES



- Standard ISO1502
- Supplied with manufacturer inspection certificate



4129-9P



4129-9PN

**WARNING: LIFE TIME IS LIMITED, CAN BE USED ABOUT 2000 TIMES**

Code example:  
"-2D5D" stands for "4129-2D5D"

Size (mm)		Code (4129)					
Nominal diameter	Pitch	Class 6g		Class 6e		Class 6h	
		GO	NOGO	GO	NOGO	GO	NOGO
M3	0.35	-3D	-3DN	-3DE	-3DEN	-3DH	-3DHN
M3.5	0.35	-3D5D	-3D5DN	-	-	-3D5DH	-3D5DHN
	0.35	-3D5G	-3D5GN	-	-	-	-
M4	0.5	-4G	-4GN	-4GE	-4GEN	-4GH	-4GHN
M4.5	0.5	-4D5G	-4D5GN	-4D5GE	-4D5GEN	-	-
M5	0.5	-5G	-5GN	-5GE	-5GEN	-5GH	-5GHN
M5.5	0.5	-5D5G	-5D5GN	-5D5GE	-	-	-
M6	0.5	-6G	-6GN	-6GE	-6GEN	-6GH	-6GHN
	0.75	-6L	-6LN	-6LE	-6LEN	-6LH	-6LHN
M6.5	0.5	-6D5G	-6D5GN	-	-	-	-
M7	0.5	-7G	-7GN	-7GE	-7GEN	-7GH	-7GHN
	0.75	-7L	-7LN	-7LE	-7LEN	-7LH	-7LHN
M7.5	0.5	-7D5G	-7D5GN	-	-	-	-
M8	0.5	-8G	-8GN	-8GE	-8GEN	-8GH	-8GHN
	0.75	-8L	-8LN	-8LE	-8LEN	-8LH	-8LHN
	1	-8P	-8PN	-8PE	-8PEN	-8PH	-8PHN
M8.5	0.5	-8D5G	-8D5GN	-	-	-	-
M9	0.5	-9G	-9GN	-9GE	-9GEN	-9GH	-9GHN
	0.75	-9L	-9LN	-9LE	-9LEN	-9LH	-9LHN
	1	-9P	-9PN	-9PE	-9PEN	-9PH	-9PHN
M10	0.5	-10G	-10GN	-10GE	-10GEN	-10GH	-10GHN
	0.75	-10L	-10LN	-10LE	-10LEN	-10LH	-10LHN
	1	-10P	-10PN	-10PE	-10PEN	-10PH	-10PHN
	1.25	-10Q	-10QN	-10QE	-10QEN	-10QH	-10QHN
M11	0.5	-11G	-11GN	-11GE	-11GEN	-11GH	-11GHN
	0.75	-11L	-11LN	-11LE	-11LEN	-11LH	-11LHN
	1	-11P	-11PN	-11PE	-11PEN	-11PH	-11PHN
M12	0.5	-12G	-12GN	-12GE	-12GEN	-12GH	-12GHN
	0.75	-12L	-12LN	-12LE	-12LEN	-12LH	-12LHN
	1	-12P	-12PN	-12PE	-12PEN	-12PH	-12PHN
	1.25	-12Q	-12QN	-12QE	-12QEN	-12QH	-12QHN
	1.5	-12R	-12RN	-12RE	-12REN	-12RH	-12RHN
M13	0.5	-13G	-13GN	-13GE	-13GEN	-13GH	-13GHN
	0.75	-13L	-13LN	-13LE	-13LEN	-13LH	-13LHN
	1	-13P	-13PN	-13PE	-13PEN	-13PH	-13PHN
	1.5	-13R	-13RN	-13RE	-13REN	-13RH	-13RHN
M14	0.5	-14G	-14GN	-14GE	-14GEN	-14GH	-14GHN
	0.75	-14L	-14LN	-14LE	-14LEN	-14LH	-14LHN
	1	-14P	-14PN	-14PE	-14PEN	-14PH	-14PHN
	1.25	-14Q	-14QN	-14QE	-14QEN	-14QH	-14QHN
	1.5	-14R	-14RN	-14RE	-14REN	-14RH	-14RHN
M15	0.5	-15G	-15GN	-15GE	-15GEN	-15GH	-15GHN
	0.75	-15L	-15LN	-15LE	-15LEN	-15LH	-15LHN
	1	-15P	-15PN	-15PE	-15PEN	-15PH	-15PHN
	1.5	-15R	-15RN	-15RE	-15REN	-15RH	-15RHN
M16	0.5	-16G	-16GN	-16GE	-16GEN	-16GH	-16GHN
	0.75	-16L	-16LN	-16LE	-16LEN	-16LH	-16LHN
	1	-16P	-16PN	-16PE	-16PEN	-16PH	-16PHN
	1.25	-16Q	-16QN	-	-	-	-
	1.5	-16R	-16RN	-16RE	-16REN	-16RH	-16RHN
M17	0.5	-17G	-17GN	-17GE	-17GEN	-17GH	-17GHN
	0.75	-17L	-17LN	-17LE	-17LEN	-17LH	-17LHN
	1	-17P	-17PN	-17PE	-17PEN	-17PH	-17PHN
	1.5	-17R	-17RN	-17RE	-17REN	-17RH	-17RHN

Size (mm)		Code (4129)					
Nominal diameter	Pitch	Class 6g		Class 6e		Class 6h	
		GO	NOGO	GO	NOGO	GO	NOGO
M18	0.5	-18G	-18GN	-	-	-18GH	-18GHN
	0.75	-18L	-18LN	-18LE	-18LEN	-18LH	-18LHN
	1	-18P	-18PN	-18PE	-18PEN	-18PH	-18PHN
	1.25	-18Q	-18QN	-	-	-18QH	-18QHN
	1.5	-18R	-18RN	-18RE	-18REN	-18RH	-18RHN
	2	-18T	-18TN	-18TE	-18TEN	-18TH	-18THN
M19	0.5	-19G	-19GN	-	-	-19GH	-19GHN
	0.75	-19L	-19LN	-19LE	-19LEN	-19LH	-19LHN
	1	-19P	-19PN	-19PE	-19PEN	-19PH	-19PHN
	1.5	-19R	-19RN	-	-	-	-
M20	0.5	-20G	-20GN	-	-	-20GH	-20GHN
	0.75	-20L	-20LN	-20LE	-20LEN	-20LH	-20LHN
	1	-20P	-20PN	-20PE	-20PEN	-20PH	-20PHN
	1.25	-20Q	-20QN	-	-	-20QH	-20QHN
	1.5	-20R	-20RN	-20RE	-20REN	-20RH	-20RHN
	2	-20T	-20TN	-20TE	-20TEN	-20TH	-20THN
M21	0.75	-21L	-21LN	-21LE	-21LEN	-	-
	1	-21P	-21PN	-21PE	-21PEN	-21PH	-21PHN
	1.5	-21R	-21RN	-	-	-	-
M22	0.75	-22L	-22LN	-	-	-	-
	1	-22P	-22PN	-22PE	-22PEN	-22PH	-22PHN
	1.25	-22Q	-22QN	-	-	-	-
	1.5	-22R	-22RN	-22RE	-22REN	-22RH	-22RHN
	2	-22T	-22TN	-22TE	-22TEN	-22TH	-22THN
M23	0.75	-23L	-23LN	-	-	-	-
	1	-23P	-23PN	-23PE	-23PEN	-23PH	-23PHN
M24	0.75	-24L	-24LN	-	-	-24LH	-24LHN
	1	-24P	-24PN	-24PE	-24PEN	-24PH	-24PHN
	1.25	-24Q	-24QN	-24QE	-24QEN	-	-
	1.5	-24R	-24RN	-24RE	-24REN	-24RH	-24RHN
	2	-24T	-24TN	-24TE	-24TEN	-24TH	-24THN
M25	0.75	-25L	-25LN	-	-	-25LH	-25LHN
	1	-25P	-25PN	-25PE	-25PEN	-25PH	-25PHN
	1.5	-25R	-25RN	-25RE	-25REN	-25RH	-25RHN
	2	-25T	-25TN	-25TE	-25TEN	-25TH	-25THN
M26	0.75	-26L	-26LN	-	-	-26LH	-26LHN
	1	-26P	-26PN	-26PE	-26PEN	-26PH	-26PHN
	1.5	-26R	-26RN	-26RE	-26REN	-26RH	-26RHN
	2	-26T	-26TN	-26TE	-26TEN	-26TH	-26THN
M27	0.75	-27L	-27LN	-	-	-	-
	1	-27P	-27PN	-27PE	-27PEN	-27PH	-27PHN
	1.5	-27R	-27RN	-27RE	-27REN	-27RH	-27RHN
	2	-27T	-27TN	-27TE	-27TEN	-27TH	-27THN
M28	0.75	-28L	-28LN	-	-	-	-
	1	-28P	-28PN	-28PE	-28PEN	-28PH	-28PHN
	1.5	-28R	-28RN	-28RE	-28REN	-28RH	-28RHN
	2	-28T	-28TN	-28TE	-28TEN	-28TH	-28THN
M29	0.75	-29L	-29LN	-	-	-	-
	1	-29P	-29PN	-	-	-	-
M30	0.75	-30L	-30LN	-30LE	-30LEN	-30LH	-30LHN
	1	-30P	-30PN	-30PE	-30PEN	-30PH	-30PHN
	1.5	-30R	-30RN	-30RE	-30REN	-30RH	-30RHN
	2	-30T	-30TN	-30TE	-30TEN	-30TH	-30THN

To be continued

Continued from previous page

Size (mm)		Code (4129)					
Nominal diameter	Pitch	Class 6g		Class 6e		Class 6h	
		GO	NOGO	GO	NOGO	GO	NOGO
M30	3	-30V	-30VN	-	-	-	-
M31	0.75	-31L	-31LN	-	-	-	-
M32	0.75	-32L	-32LN	-	-	-	-
	1	-32P	-32PN	-32PE	-32PEN	-32PH	-32PHN
	1.5	-32R	-32RN	-32RE	-32REN	-32RH	-32RHN
M33	2	-32T	-32TN	-32TE	-32TEN	-32TH	-32THN
	0.75	-33L	-33LN	-	-	-	-
	1	-33P	-33PN	-33PE	-33PEN	-33PH	-33PHN
M34	1.5	-33R	-33RN	-33RE	-33REN	-33RH	-33RHN
	2	-33T	-33TN	-33TE	-33TEN	-33TH	-33THN
	3	-33V	-33VN	-	-	-	-
M35	1	-34P	-34PN	-34PE	-34PEN	-34PH	-34PHN
	1.5	-34R	-34RN	-34RE	-34REN	-34RH	-34RHN
M36	2	-34T	-34TN	-	-	-	-
	1	-35P	-35PN	-35PE	-35PEN	-35PH	-35PHN
M38	1.5	-35R	-35RN	-35RE	-35REN	-35RH	-35RHN
	2	-35T	-35TN	-	-	-	-
M39	1	-36P	-36PN	-36PE	-36PEN	-36PH	-36PHN
	1.5	-36R	-36RN	-36RE	-36REN	-36RH	-36RHN
	2	-36T	-36TN	-36TE	-36TEN	-36TH	-36THN
M40	3	-36V	-36VN	-	-	-36VH	-36VHN
	1	-38P	-38PN	-38PE	-38PEN	-38PH	-38PHN
M42	1.5	-38R	-38RN	-38RE	-38REN	-38RH	-38RHN
	2	-38T	-38TN	-38TE	-38TEN	-38TH	-38THN
M48	1	-39P	-39PN	-	-	-	-
	1.5	-39R	-39RN	-39RE	-39REN	-39RH	-39RHN
	2	-39T	-39TN	-39TE	-39TEN	-39TH	-39THN
M50	3	-39V	-39VN	-	-	-	-
	1.5	-40R	-40RN	-40RE	-40REN	-40RH	-40RHN
	2	-40T	-40TN	-40TE	-40TEN	-40TH	-40THN
M52	3	-40V	-40VN	-	-	-	-
	1.5	-42R	-42RN	-42RE	-42REN	-42RH	-42RHN

Size (mm)		Code (4129)					
Nominal diameter	Pitch	Class 6g		Class 6e		Class 6h	
		GO	NOGO	GO	NOGO	GO	NOGO
M42	2	-42T	-42TN	-42TE	-42TEN	-42TH	-42THN
	3	-42V	-42VN	-	-	-	-
M45	1.5	-45R	-45RN	-45RE	-45REN	-45RH	-45RHN
	2	-45T	-45TN	-45TE	-45TEN	-45TH	-45THN
	3	-45V	-45VN	-45VE	-	-	-
M48	1.5	-48R	-48RN	-48RE	-48REN	-48RH	-48RHN
	2	-48T	-48TN	-48TE	-48TEN	-48TH	-48THN
M50	3	-48V	-48VN	-	-	-48VH	-48VHN
	1.5	-50R	-50RN	-50RE	-50REN	-50RH	-50RHN
	2	-50T	-50TN	-50TE	-50TEN	-50TH	-50THN
M52	3	-50V	-50VN	-	-	-	-
	1.5	-52R	-52RN	-52RE	-52REN	-52RH	-52RHN
M55	2	-52T	-52TN	-52TE	-52TEN	-52TH	-52THN
	3	-52V	-52VN	-	-	-52VH	-52VHN
M56	4	-52X	-52XN	-	-	-	-
	1.5	-55R	-55RN	-55RE	-55REN	-55RH	-55RHN
	2	-55T	-55TN	-55TE	-55TEN	-55TH	-55THN
M58	3	-55V	-55VN	-	-	-	-
	4	-55X	-55XN	-	-	-	-
M60	1.5	-56R	-56RN	-56RE	-56REN	-56RH	-56RHN
	2	-56T	-56TN	-56TE	-56TEN	-56TH	-56THN
	3	-56V	-56VN	-	-	-56VH	-56VHN
M60	4	-56X	-56XN	-	-	-	-
	1.5	-58R	-58RN	-58RE	-58REN	-58RH	-58RHN
M60	2	-58T	-58TN	-58TE	-58TEN	-58TH	-58THN
	3	-58V	-58VN	-	-	-	-
	4	-58X	-58XN	-	-	-	-
M60	1.5	-60R	-60RN	-60RE	-60REN	-60RH	-60RHN
	2	-60T	-60TN	-60TE	-60TEN	-60TH	-60THN
M60	3	-60V	-60VN	-	-	-	-
	4	-60X	-60XN	-	-	-	-

## AMERICAN STANDARD THREAD PLUG GAGES

- Supplied with Go and No-Go gages together
- Standard ANSI/ASME B1.2
- Supplied with manufacturer inspection certificate



4131-102

Code example:  
"-9D1" stands for "4131-9D1"WARNING: LIFE TIME IS LIMITED,  
CAN BE USED ABOUT 2000 TIMES

Size	Code (4131)		Size	Code (4131)		Size	Code (4131)		Size	Code (4131)	
	Class 2B	Class 3B		Class 2B	Class 3B		Class 2B	Class 3B		Class 2B	Class 3B
No. 0-80UNF	-02	-02B	No. 12-28UNF	-122	122B	9/16-12UNC	-9D1	-9D1B	1-8UNC	-2A1	-2A1B
No. 1-64UNC	-11	-11B	No. 12-32UNEF	-123	-	9/16-18UNF	-9D2	-9D2B	1-12UNF	-2A2	-2A2B
No. 1-72UNF	-12	-12B	1/4-20UNC	-1B1	-1B1B	9/16-24UNEF	-9D3	-9D3B	1-14UNS	-2A514	-
No. 2-56UNC	-21	-21B	1/4-28UNF	-1B2	-1B2B	5/8-11UNC	-5C1	-5C1B	1-20UNEF	-2A3	-
No. 2-64UNF	-22	-22B	1/4-32UNEF	-1B3	-	5/8-18UNF	-5C2	-5C2B	1-32UN	-2A532	-2A532B
No. 3-48UNC	-31	-31B	1/4-36UNS	-1B4	-	5/8-24UNEF	-5C3	-5C3B	1 1/16-12UN	-1E512	-
No. 3-56UNF	-32	-32B	5/16-18UNC	-5D1	-5D1B	11/16-16UN	-11D516	-	1 1/16-18UNEF	-1E3	-
No. 4-40UNC	-41	-41B	5/16-24UNF	-5D2	-5D2B	11/16-24UNEF	-11D3	-	1 1/8-7UNC	-1F1	-1F1B
No. 4-48UNF	-42	-42B	5/16-32UNEF	-5D3	-5D3B	3/4-10UNC	-3B1	-3B1B	1 1/8-8UN	-1F58	-1F58B
No. 5-40UNC	-51	-51B	3/8-16UNC	-3C1	-3C1B	3/4-16UNF	-3B2	-3B2B	1 1/8-12UNF	-1F2	-1F2B
No. 5-44UNF	-52	-52B	3/8-24UNF	-3C2	-3C2B	3/4-20UNEF	-3B3	-3B3B	1 1/8-18UNEF	-1F3	-
No. 6-32UNC	-61	-61B	3/8-32UNEF	-3C3	-	13/16-16UN	-13D516	-	1 3/16-12UN	-3E512	-
No. 6-40UNF	-62	-62B	7/16-14UNC	-7D1	-7D1B	13/16-20UNEF	-13D3	-	1 3/16-18UNEF	-3E3	-
No. 8-32UNC	-81	-81B	7/16-20UNF	-7D2	-7D2B	7/8-9UNC	-7C1	-7C1B	1 1/4-7UNC	-1G1	-
No. 8-36UNF	-82	-82B	7/16-28UNEF	-7D3	-	7/8-14UNF	-7C2	-7C2B	1 1/4-8UN	-1G58	-1G58B
No. 10-24UNC	-101	-101B	1/2-13UNC	-1A1	-1A1B	7/8-16UN	-7C516	-	1 1/4-12UNF	-1G2	-1G2B
No. 10-32UNF	-102	-102B	1/2-20UNF	-1A2	-1A2B	7/8-20UNEF	-7C3	-7C3B	1 1/4-18UNEF	-1G3	-
No. 12-24UNC	-121	-121B	1/2-28UNEF	-1A3	-	15/16-20UNEF	-15D3	-	1 5/16-12UN	-5E512	-

## AMERICAN STANDARD THREAD RING GAGES

WARNING: LIFE TIME IS LIMITED,  
CAN BE USED ABOUT 2000 TIMES



- Standard ANSI/ASME B1.2
- Class 2A
- Supplied with manufacturer inspection certificate



4121-1B1

4121-1B1N

Size	Code	
	GO	NOGO
No. 4-40UNC	4121-41	4121-41N
No. 4-48UNF	4121-42	4121-42N
No. 5-40UNC	4121-51	4121-51N
No. 5-44UNF	4121-52	4121-52N
No. 6-32UNC	4121-61	4121-61N
No. 6-40UNF	4121-62	4121-62N
No. 8-32UNC	4121-81	4121-81N
No. 8-36UNF	4121-82	4121-82N
No. 10-24UNC	4121-101	4121-101N
No. 10-32UNF	4121-102	4121-102N
No. 12-24UNC	4121-121	4121-121N
No. 12-28UNF	4121-122	4121-122N
No. 12-32UNEF	4121-123	4121-123N
1/4-20UNC	4121-1B1	4121-1B1N
1/4-28UNF	4121-1B2	4121-1B2N
1/4-32UNEF	4121-1B3	4121-1B3N
1/4-36UNS	4121-1B4	4121-1B4N
5/16-18UNC	4121-5D1	4121-5D1N
5/16-24UNF	4121-5D2	4121-5D2N
5/16-32UNEF	4121-5D3	4121-5D3N
3/8-16UNC	4121-3C1	4121-3C1N
3/8-24UNF	4121-3C2	4121-3C2N

Size	Code	
	GO	NOGO
3/8-32UNEF	4121-3C3	4121-3C3N
7/16-14UNC	4121-7D1	4121-7D1N
7/16-20UNF	4121-7D2	4121-7D2N
7/16-28UNEF	4121-7D3	4121-7D3N
1/2-13UNC	4121-1A1	4121-1A1N
1/2-20UNF	4121-1A2	4121-1A2N
1/2-28UNEF	4121-1A3	4121-1A3N
9/16-12UNC	4121-9D1	4121-9D1N
9/16-18UNF	4121-9D2	4121-9D2N
9/16-24UNEF	4121-9D3	4121-9D3N
5/8-11UNC	4121-5C1	4121-5C1N
5/8-18UNF	4121-5C2	4121-5C2N
5/8-24UNEF	4121-5C3	4121-5C3N
11/16-16UN	4121-11D516	4121-11D516N
11/16-24UNEF	4121-11D3	4121-11D3N
3/4-10UNC	4121-3B1	4121-3B1N
3/4-16UNF	4121-3B2	4121-3B2N
3/4-20UNEF	4121-3B3	4121-3B3N
13/16-16UN	4121-13D516	4121-13D516N
13/16-20UNEF	4121-13D3	4121-13D3N
7/8-9UNC	4121-7C1	4121-7C1N
7/8-14UNF	4121-7C2	4121-7C2N

Size	Code	
	GO	NOGO
7/8-16UN	4121-7C516	4121-7C516N
7/8-20UNEF	4121-7C3	4121-7C3N
15/16-20UNEF	4121-15D3	4121-15D3N
1-8UNC	4121-2A1	4121-2A1N
1-12UNF	4121-2A2	4121-2A2N
1-14UNS	4121-2A514	4121-2A514N
1-20UNEF	4121-2A3	4121-2A3N
1-32UN	4121-2A532	4121-2A532N
1 1/16-12UN	4121-1E512	4121-1E512N
1 1/16-18UNEF	4121-1E3	4121-1E3N
1 1/8-7UNC	4121-1F1	4121-1F1N
1 1/8-8UN	4121-1F58	4121-1F58N
1 1/8-12UNF	4121-1F2	4121-1F2N
1 1/8-18UNEF	4121-1F3	4121-1F3N
1 3/16-12UN	4121-3E512	4121-3E512N
1 3/16-18UNEF	4121-3E3	4121-3E3N
1 1/4-7UNC	4121-1G1	4121-1G1N
1 1/4-8UN	4121-1G58	4121-1G58N
1 1/4-12UNF	4121-1G2	4121-1G2N
1 1/4-18UNEF	4121-1G3	4121-1G3N
1 5/16-12UN	4121-5E512	4121-5E512N

## WATERPROOF DIGITAL PROTRACTOR (HEAVY DUTY)

AUTOMATIC  
BACKLIGHT

ABSOLUTE  
LEVEL

IP54  
WATERPROOF

- Suitable for setting horizontal and vertical mitre angles of cutting machine
- Buttons: ON/OFF, HOLD/SUP, SPR/CNR/MTR/BVL
- IP54 dust/waterproof
- With transverse and longitudinal vials
- 2xAAA batteries
- Absolute level, zero setting is not needed when batteries are replaced
- Backlight turns off in one minute after no data changing, automatic power off in 5 minutes



2174-225

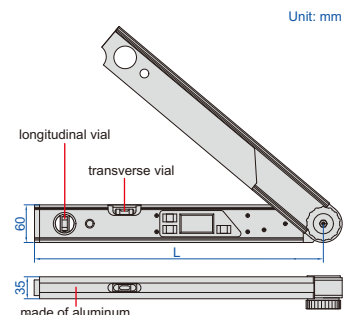

Code	Size (L)	Range	Resolution	Accuracy
2174-225	460mm	0-225°	0.05°	±0.10°

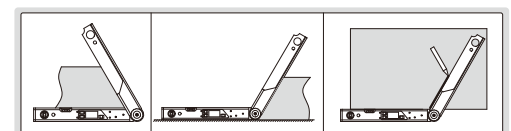

## DIGITAL PROTRACTOR

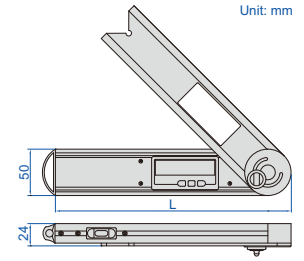
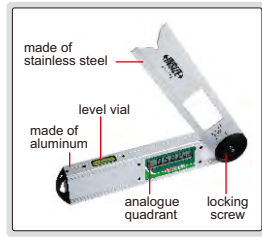
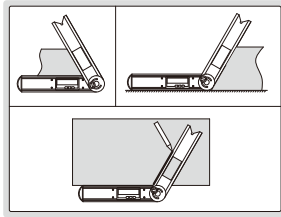

- Buttons: on/off, hold (keep the reading), zero, ABS (absolute and incremental measurement)
- Fix the locking screw at 4 positions for different measuring ranges: 0°~225°, -225°~0°, -45°~180°, -180°~45°
- Remove the locking screw for 360° range
- With level vial
- Battery CR2032
- Automatic power off

2171-250

Code	Size (L)	Range	Resolution	Accuracy
2171-250	250mm	0-360°	0.05°	±0.15°

## DIGITAL PROTRACTORS

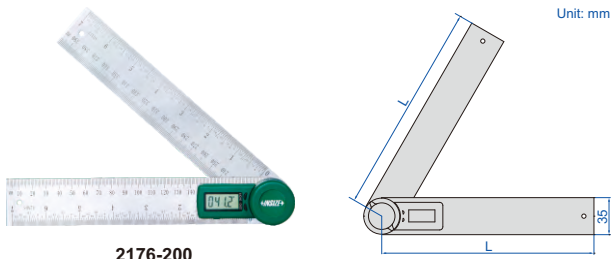

2176-200

- Accuracy: ±0.3°
- Resolution: 0.1°
- Buttons: on/off, zero
- With clamping screw to lock the blades
- Graduation of blade: 1mm and 1/32"
- Made of stainless steel
- CR2032 battery, automatic power off

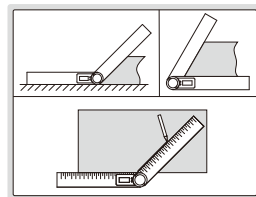

Code	Size (L)	Range
2176-200	200mm	0-360°
2176-300	300mm	0-360°

## PROTRACTOR (ECONOMIC TYPE)



4780-85A

- Graduation: 1°
- Made of stainless steel
- With clamping screw

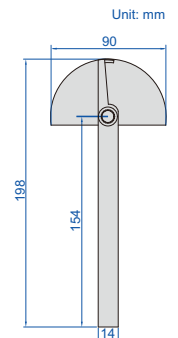

Code	Size	Range	Accuracy
4780-85A	90x154mm	0-180°	±0.5°

## PROTRACTOR



4781-85A

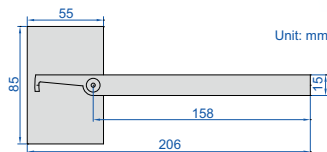

- Graduation: 1°
- Accuracy: ±0.3°
- Made of stainless steel
- Satin chrome plated scale
- With clamping screw

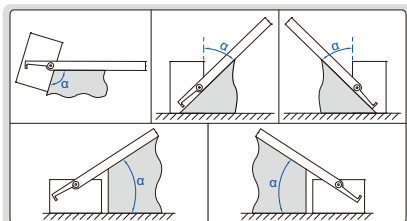

Code	Size	Range
4781-85A	85x158mm	0-180°

## PROTRACTORS



4799-180

- Graduation: 1°
- Made of stainless steel (4799-1300 is made of carbon steel)
- Satin chrome plated scale
- With clamping screw

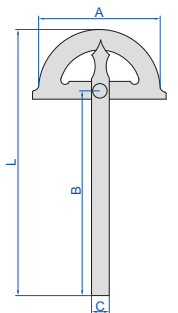

Code	Size (AxB)	Range	Accuracy	L	C
4799-180	80x120mm	0-180°	±0.3°	168mm	11mm
4799-1120	120x150mm	0-180°	±0.3°	220mm	14mm
4799-1150	150x200mm	0-180°	±0.3°	285mm	16mm
4799-1200	200x300mm	0-180°	±0.3°	413mm	20mm
4799-1300	300x500mm	0-180°	±0.3°	675mm	30mm

## PROTRACTORS



4797-100

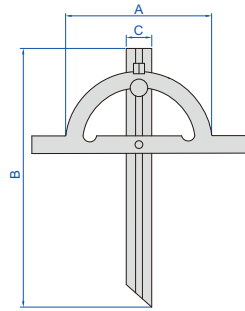
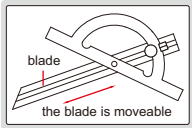

- Graduation: 1°
- Made of carbon steel
- Satin chrome plated
- With clamping screw
- The blade is moveable

Code	Size (AxB)	Range	Accuracy	C
4797-100	100x150mm	10-170°	±0.3°	18mm
4797-150	150x300mm	10-170°	±0.3°	22mm
4797-200	200x400mm	10-170°	±0.3°	24mm
4797-250	250x500mm	10-170°	±0.3°	28mm
4797-300	300x600mm	10-170°	±0.3°	32mm

## PROTRACTOR



2374-320

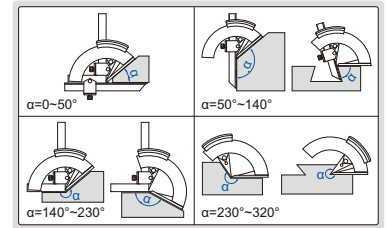
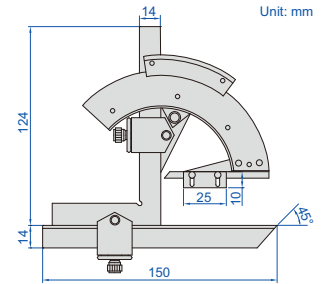

- Graduation: 2'
- Made of stainless steel
- Satin chrome plated scale

Code	Range	Accuracy
2374-320	0-320°	±2'

## UNIVERSAL PROTRACTOR

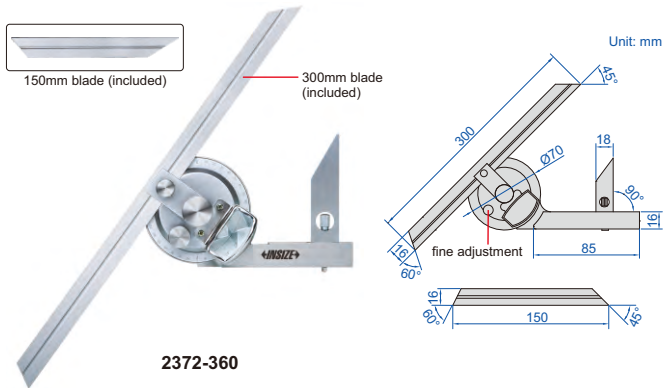

2372-360

clamp for height gages (optional)

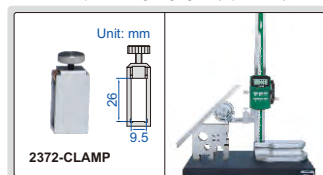

- Parallax-free reading
- Made of stainless steel
- Optional accessory: clamp (code 2372-CLAMP), suitable for height gages 1156, 1150-300, 1351, 1151 and 1250

Code	Range	Graduation	Accuracy
2372-360	0-360°	5'	±5'

## DIAL PROTRACTOR

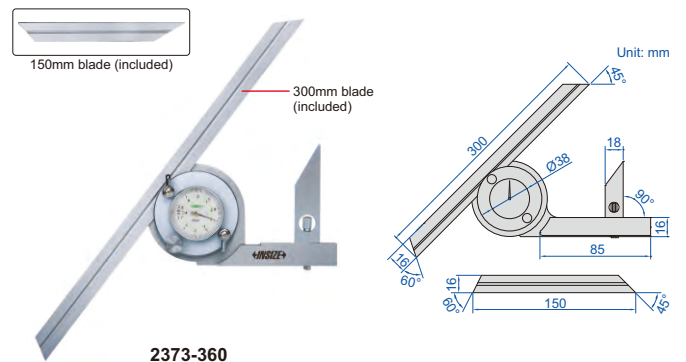

2373-360

clamp for height gages (optional)

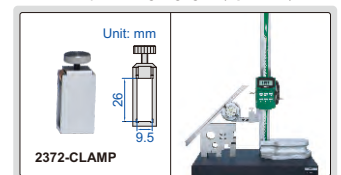

- Made of stainless steel
- Optional accessory: clamp (code 2372-CLAMP), suitable for height gages 1156, 1150-300, 1351, 1151 and 1250

Code	Range	Graduation	Accuracy
2373-360	0-360°	5'	±5'

## DIGITAL PROTRACTOR

**POPULAR MODEL** **ABSOLUTE ZERO** **DATA OUTPUT**

clamp for height gages (optional)

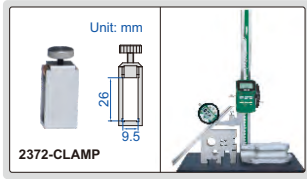

150mm blade (included)

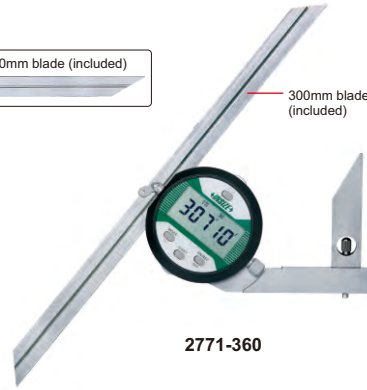

2771-360

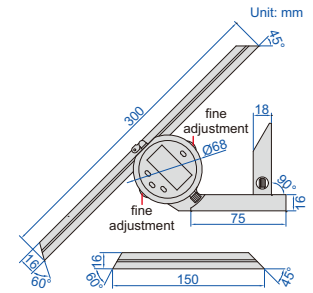

- Absolute zero, zero setting is not needed when batteries are replaced
- Button function: choose 0~90°, 0-180° or 0-360° display, change resolution, display flips over, data hold, zero, on/off supplementary angle measurement
- Battery CR2032, automatic power off
- Data output
- Made of stainless steel
- Optional square for zero setting
- Optional accessory: clamp (code 2372-CLAMP), suitable for height gages 1156, 1150-300, 1351, 1250 and 1151, data output cable (code 7315-2771 need receiver, 7302-50M)

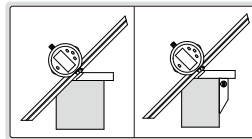

square (optional)

Square (for zero setting, optional)

Code  
2771-S90



Code	Range	Resolution	Accuracy
2771-360	0-360°	1/0.01°	±5'

## GRANITE SQUARES

CUSTOM-MADE  
SUPPLY SPECIAL SIZES ACCORDING  
TO CUSTOMER'S REQUEST



4141-250

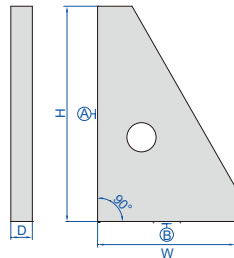

Code	Size (HxW)	Flatness of A	Flatness of B	Squareness of A to B	D
4141-250	250x160mm	1μm	1μm	2μm	25mm
4141-400	400x250mm	1.5μm	1μm	3μm	40mm
4141-630	630x400mm	2μm	1.5μm	4μm	63mm

## ANGLE BLOCK SET

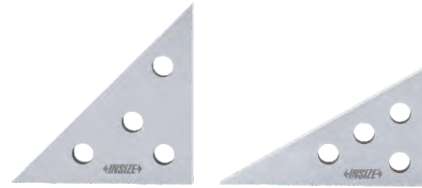

6540-1

- For angle set-up in tooling, production and inspection
- Accuracy of angle: ±9 seconds
- Made of alloy steel
- Hardness HRC60±2

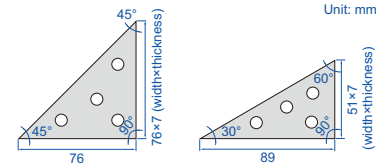

Code	Angle plates included	Angle
6540-1	2	45°, 45°, 90° 30°, 60°, 90°

## PERPENDICULARITY TESTERS



- Optional accessory: dial test indicators (graduation: 1μm or 2μm)



dial test indicator is optional



4770-300

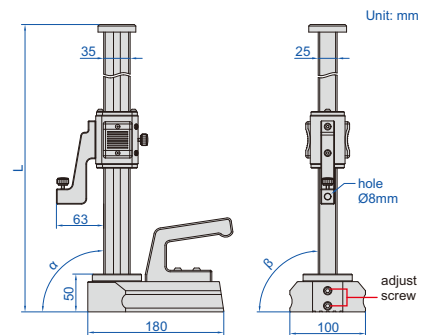

Code	Range (H)	Perpendicularity (α)	Side perpendicularity (β)	L
4770-300	0-300mm	3μm	10μm	460mm
4770-600	0-600mm	5μm	20μm	760mm

### 90° BEVELED EDGE SQUARES

- Satin chrome plating
- Beveled edges for inside and outside measurement
- Made of hardened stainless steel

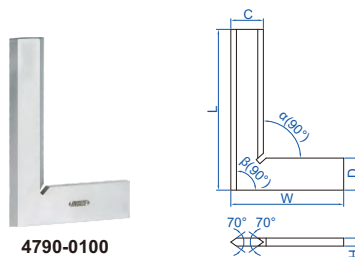

4790-0100

#### DIN875 grade 00

Code	Size (LxW)	Squareness		C	D	H
		Inside (α)	Outside (β)			
4790-050	50x40mm	2.4μm	2.5μm	13	13	4
4790-075	75x50mm	2.6μm	2.8μm	15	15	4
4790-0100	100x70mm	2.8μm	3.0μm	20	20	5
4790-0150	150x100mm	3.2μm	3.5μm	30	30	6
4790-0200	200x130mm	3.7μm	4.0μm	34	34	7
4790-0300	300x200mm	4.6μm	5.0μm	40	40	8

#### DIN875 grade 0

Code	Size (LxW)	Squareness		C	D	H
		Inside (α)	Outside (β)			
4790-500	50x40mm	6μm	6μm	13	13	4
4790-750	75x50mm	6μm	7μm	15	15	4
4790-1000	100x70mm	7μm	7μm	20	20	5
4790-1500	150x100mm	7μm	8μm	30	30	6
4790-2000	200x130mm	8μm	9μm	34	34	7
4790-3000	300x200mm	10μm	11μm	40	40	8

### 90° FLAT EDGE SQUARES

- Made of hardened stainless steel

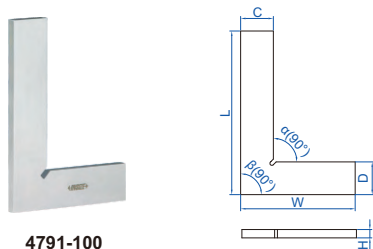

4791-100

#### DIN875 grade 1

Code	Size (LxW)	Squareness		C	D	H
		Inside (α)	Outside (β)			
4791-501	50x40mm	12μm	13μm	15	15	4
4791-751	75x50mm	13μm	14μm	15	15	4
4791-1001	100x70mm	14μm	15μm	20	20	5
4791-1501	150x100mm	16μm	18μm	30	30	6
4791-2001	200x130mm	19μm	20μm	30	30	7
4791-2501	250x165mm	21μm	23μm	35	35	7
4791-3001	300x200mm	23μm	25μm	40	40	8

#### DIN875 grade 0

Code	Size (LxW)	Squareness		C	D	H
		Inside (α)	Outside (β)			
4791-50	50x40mm	6μm	6μm	15	15	4
4791-75	75x50mm	6μm	7μm	15	15	4
4791-100	100x70mm	7μm	7μm	20	20	5
4791-150	150x100mm	7μm	8μm	30	30	6
4791-200	200x130mm	8μm	9μm	30	30	7
4791-250	250x165mm	9μm	10μm	35	35	7
4791-300	300x200mm	10μm	11μm	40	40	8

#### DIN875 grade 2

Code	Size (LxW)	Squareness		C	D	H
		Inside (α)	Outside (β)			
4791-502	50x40mm	24μm	25μm	15	15	4
4791-752	75x50mm	26μm	28μm	15	15	4
4791-1002	100x70mm	28μm	30μm	20	20	5
4791-1502	150x100mm	33μm	35μm	30	30	6
4791-2002	200x130mm	38μm	40μm	30	30	7
4791-2502	250x165mm	43μm	45μm	35	35	7
4791-3002	300x200mm	47μm	50μm	40	40	8

### MACHINIST SQUARES (ECONOMIC TYPE)

ATTENTION: NO ANTI-RUST TREATMENT, NOT HARDEND

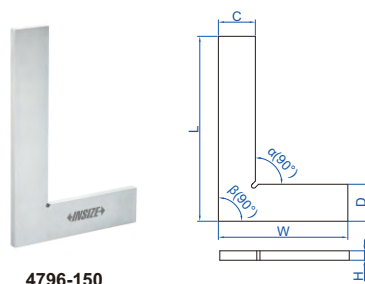

4796-150

- DIN875 grade 2
- Made of carbon steel, no anti-rust treatment, not hardend

Code	Size (LxW)	Squareness		C	D	H
		Inside (α)	Outside (β)			
4796-50	50x30mm	24μm	25μm	12	12	3
4796-75	75x50mm	26μm	28μm	16	16	3
4796-100	100x70mm	28μm	30μm	19	19	5
4796-125	125x80mm	30μm	33μm	22	22	5
4796-150	150x100mm	33μm	35μm	25	25	6
4796-200	200x130mm	38μm	40μm	25	25	6
4796-250	250x165mm	43μm	45μm	25	25	6
4796-300	300x200mm	47μm	50μm	30	30	6
4796-350	350x200mm	51μm	55μm	38	38	6
4796-400	400x200mm	56μm	60μm	38	38	9
4796-450	450x250mm	58μm	65μm	38	38	9
4796-500	500x300mm	69μm	70μm	38	38	9



### 90° FLAT EDGE SQUARES WITH WIDE BASE

- Made of hardened stainless steel

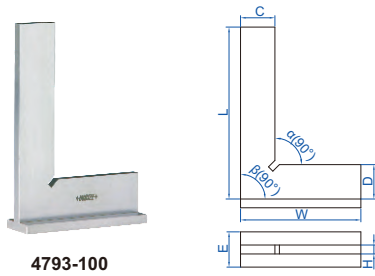

4793-100

#### DIN875 grade 1

(mm)

Code	Size (LxW)	Squareness		C	D	H	E
		Inside (α)	Outside (β)				
4793-501	50x40mm	12μm	13μm	15	15	4	13
4793-751	75x50mm	13μm	14μm	15	15	4	15
4793-1001	100x70mm	14μm	15μm	20	20	5	20
4793-1501	150x100mm	16μm	18μm	30	30	6	30
4793-2001	200x130mm	19μm	20μm	30	30	7	30
4793-2501	250x165mm	21μm	23μm	35	35	7	35
4793-3001	300x200mm	23μm	25μm	40	40	8	40

#### DIN875 grade 0

(mm)

Code	Size (LxW)	Squareness		C	D	H	E
		Inside (α)	Outside (β)				
4793-50	50x40mm	6μm	6μm	15	15	4	13
4793-75	75x50mm	6μm	7μm	15	15	4	15
4793-100	100x70mm	7μm	7μm	20	20	5	20
4793-150	150x100mm	7μm	8μm	30	30	6	30
4793-200	200x130mm	8μm	9μm	30	30	7	30
4793-250	250x165mm	9μm	10μm	35	35	7	35
4793-300	300x200mm	10μm	11μm	40	40	8	40

#### DIN875 grade 2

(mm)

Code	Size (LxW)	Squareness		C	D	H	E
		Inside (α)	Outside (β)				
4793-502	50x40mm	24μm	25μm	15	15	4	13
4793-752	75x50mm	26μm	28μm	15	15	4	15
4793-1002	100x70mm	28μm	30μm	20	20	5	20
4793-1502	150x100mm	33μm	35μm	30	30	6	30
4793-2002	200x130mm	38μm	40μm	30	30	7	30
4793-2502	250x165mm	43μm	45μm	35	35	7	35
4793-3002	300x200mm	47μm	50μm	40	40	8	40

### 90° FLAT EDGE SQUARES WITH WIDE BASE

- DIN875 grade 0
- Made of hardened stainless steel

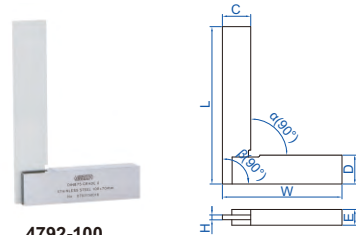

4792-100

(mm)

Code	Size (LxW)	Squareness		C	D	H	E
		Inside (α)	Outside (β)				
4792-50	50x40mm	6μm	6μm	12	12	3	10
4792-75	75x50mm	6μm	7μm	14	14	3	10
4792-100	100x70mm	7μm	7μm	18	18	3	10
4792-150	150x100mm	8μm	8μm	22	22	4	12
4792-200	200x130mm	9μm	9μm	25	25	4	12

### MACHINIST SQUARES WITH WIDE BASE (ECONOMIC TYPE)

ATTENTION: NO ANTI-RUST TREATMENT, NOT HARDENED

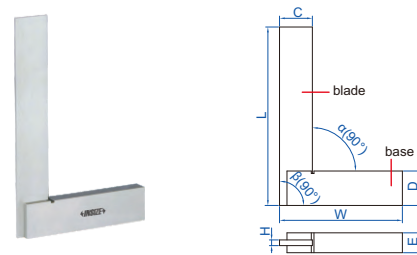

4707-100

- DIN875 grade 2
- Made of carbon steel, no anti-rust treatment, not hardened

### TRY SQUARE

- Graduation: 1mm
- Stainless steel blade, aluminum base

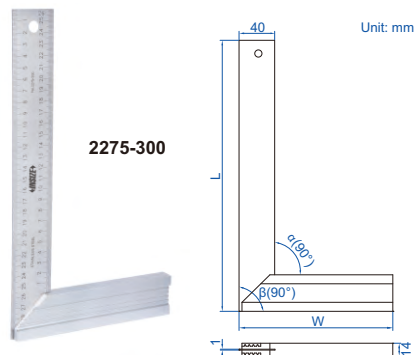

2275-300

Unit: mm

Code	Size (LxW)	Squareness	
		Inside (α)	Outside (β)
2275-300	300x170mm	0.5mm	0.5mm

(mm)

Code	Size (LxW)	Squareness		C	D	H	E
		Inside (α)	Outside (β)				
4707-50	50x40mm	24μm	25μm	16	12	3	9
4707-75	75x50mm	26μm	28μm	16	16	3	9
4707-100	100x70mm	28μm	30μm	19	19	3	12
4707-150	150x100mm	33μm	35μm	25	25	3	16
4707-200	200x130mm	37μm	40μm	30	32	4	16
4707-250	250x165mm	42μm	45μm	30	32	4	19
4707-300	300x200mm	47μm	50μm	32	32	4	19
4707-400	400x250mm	56μm	60μm	38	38	5	22
4707-500	500x300mm	65μm	70μm	45	50	6	25
4707-600	600x350mm	75μm	80μm	50	50	6	30
4707-750	750x400mm	90μm	95μm	55	55	6	50
4707-900	900x500mm	103μm	110μm	65	75	9	50
4707-1000	1000x550mm	113μm	120μm	65	75	9	50

### TRY SQUARE



2280-300

- Graduation: 1mm
- Aluminum blade and base
- 4 milled surfaces
- Retractable metal ledge support
- Etchings and holes for beveling and framing: 10°, 15°, 22.5°, 30°, 45°, 50° and 60°
- Etchings and holes every cm for fluid pencil marking

Code	Size (LxW)	Squareness	
		Inside (α)	Outside (β)
2280-300	300x150mm	0.5mm	0.5mm

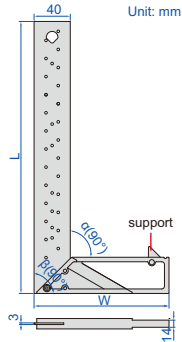

### STRAIGHT EDGES



4700-100

- DIN874
- Beveled edge
- Made of hardened stainless steel
- Satin chrome plating

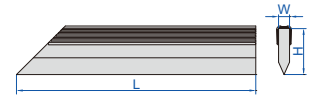

Code	Size (L)	Straightness	W	H
4700-100	100mm	2.4µm	5	25
4700-150	150mm	2.6µm	6	30
4700-200	200mm	2.8µm	6	30
4700-300	300mm	3.2µm	8	40

### 45° SQUARES WITH WIDE BASE

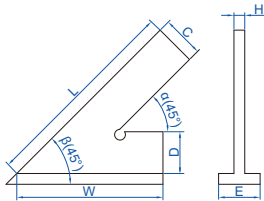

4747-150

- Made of hardened stainless steel

Code	Size (LxW)	Accuracy		C	D	H	E
		Inside (α)	Outside (β)				
4747-150	150x100mm	32µm	36µm	20	20	5	20
4747-200	200x130mm	36µm	41µm	25	25	5	25

### GRANITE STRAIGHT EDGES



4147-500A

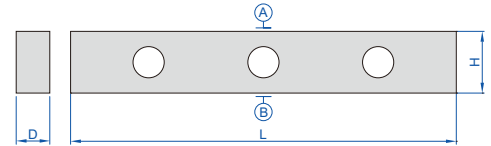

Code	Length (L)	Flatness of A and B	Parallelism between A and B	D	H
4147-500A	500mm	2.1µm	3.2µm	50mm	80mm
4147-1000A	1000mm	3.0µm	4.5µm	60mm	120mm

### MAGNALIUM STRAIGHT EDGES

LIGHT WEIGHT



4180-1500

- Made of magnalium, light weight, non-deform, no rusty

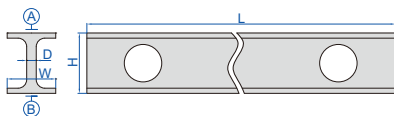

Code	Length (L)	Flatness of A and B	Parallelism between A and B	H	W	D	Weight
4180-500	500mm	3µm	4µm	60	30	5	1kg
4180-1000	1000mm	5µm	8µm	60	30	5	1.5kg
4180-1500	1500mm	15µm	22µm	100	40	7	4.5kg
4180-2000	2000mm	18µm	27µm	100	40	7	6kg
4180-3000	3000mm	48µm	72µm	150	80	8	21kg

### STRAIGHT EDGES



7111-300A

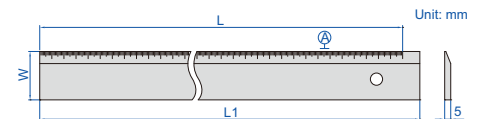
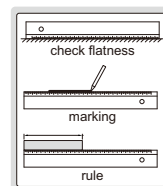

- Check flatness and straightness, as well as for marking
- Graduation on the beveled edge
- Made of hardened tool steel
- Chrome plated

Code	Range (L)	Straightness of A	L1	W
7111-300A	300mm	0.02mm	310mm	40mm
7111-500A	500mm	0.03mm	510mm	40mm

## STRAIGHTNESS/FLATNESS GAGE



DATA OUTPUT

GRANITE HOLDER CAN BE CUSTOMIZED ACCORDING TO WORKPIECES

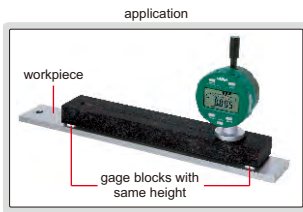

2144-200

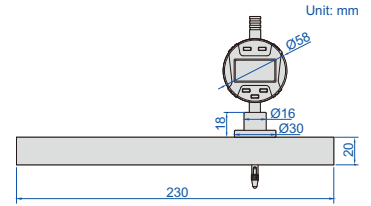

- Optional accessory: data output cable (code 7315-50M need receiver, 7302-40M)

Code	Range	Digital indicator resolution	Straightness measurement accuracy	Parallelism of top and bottom surfaces of granite holder	Flatness of top and bottom surfaces of granite holder
2144-200	200mm	0.001mm/0.00005"	3µm	2µm	1.5µm

## FLATNESS MEASUREMENT STAND



6852-150

GRANITE PLATE CAN BE CUSTOMIZED ACCORDING TO WORKPIECES



DATA OUTPUT

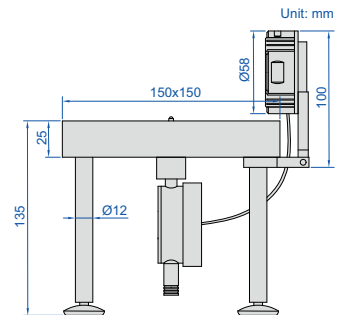

- Optional accessory: data output cable (code 7315-50M need receiver, 7302-40M, 7305-40M)

Code	Digital indicator resolution	Flatness measurement accuracy	Flatness of granite plate
6852-150	0.001mm/0.00005"	2µm	2µm

## CONCENTRICITY GAGES

- Accuracy 2µm
- Optional accessory: dial test indicator

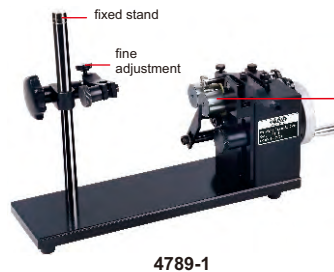

4789-1

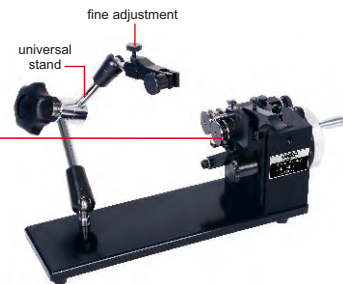
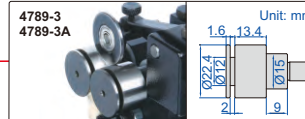
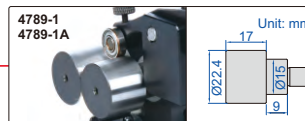

4789-2A

Code	Applicable diameter	Remark
4789-1	Ø3.5mm-25mm	fixed stand, high accuracy, inconvenient operation
4789-2	Ø1mm-25mm	
4789-3	Ø1mm-25mm	
4789-1A	Ø3.5mm-25mm	universal stand, low accuracy, convenient operation
4789-2A	Ø1mm-25mm	
4789-3A	Ø1mm-25mm	

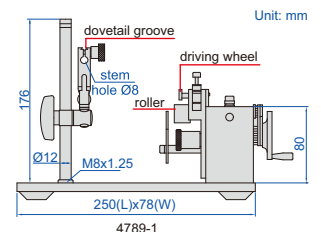
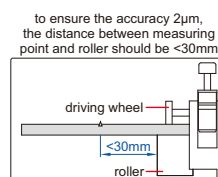

**CONCENTRICITY GAGES**

**HIGH STABILITY,  
LONG WORKING LIFE**

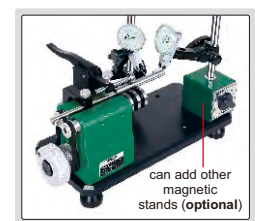
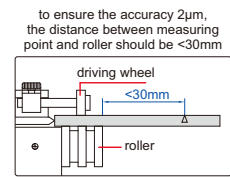
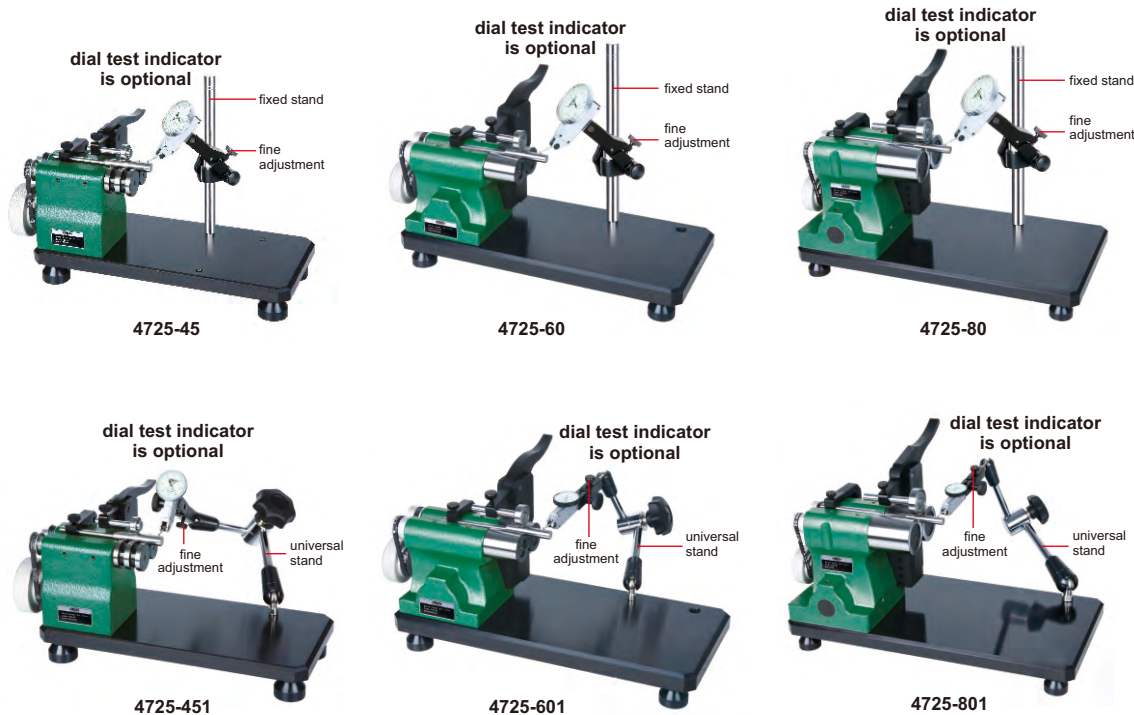

- With ball bearing, high stability, long working life
- Accuracy:  $2\mu\text{m}$
- Optional accessory: dial test indicator

Code	Diameter range	Center height (h)	LxWxH	Weight	Remark
4725-45	$\varnothing 3-45\text{mm}$	80mm	280x130x170mm	6kg	fixed stand, high accuracy, inconvenient operation
4725-60	$\varnothing 8-60\text{mm}$	90mm	350x160x190mm	15.6kg	
4725-80	$\varnothing 8-80\text{mm}$	130mm	400x200x250mm	25kg	
4725-451	$\varnothing 3-45\text{mm}$	80mm	280x130x170mm	6kg	universal stand, low accuracy, convenient operation
4725-601	$\varnothing 8-60\text{mm}$	90mm	350x160x190mm	15.6kg	
4725-801	$\varnothing 8-80\text{mm}$	130mm	400x200x250mm	25kg	

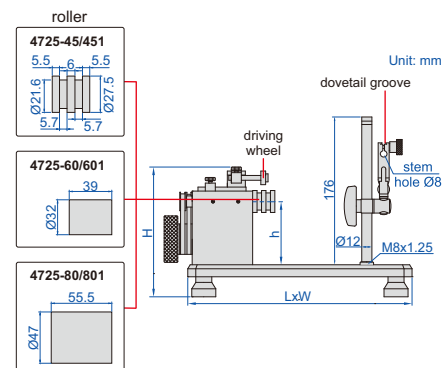

**CONCENTRICITY GAGES**

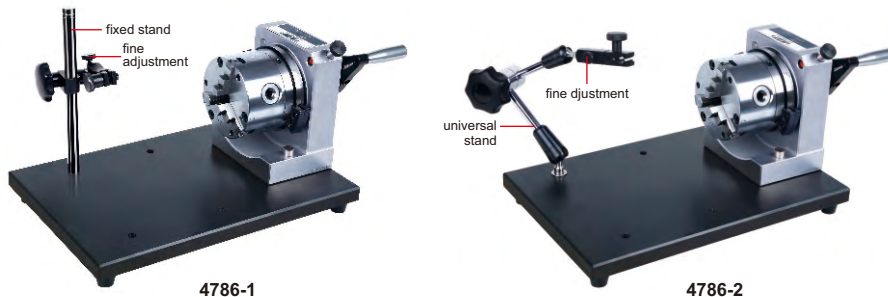
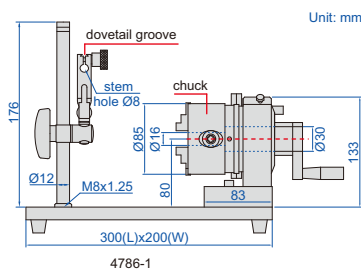

- Accuracy:  $3\mu\text{m}$
- $\varnothing 50\text{mm}$  setting ring and  $\varnothing 55\text{mm}$  calibration cylinder are included
- Optional accessory: dial test indicator

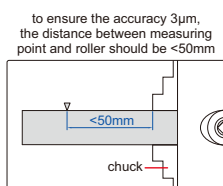

Code	Applicable inside diameter	Applicable outside diameter	Remark
4786-1	$\varnothing 24-64\text{mm}$	$\varnothing 2-70\text{mm}$	fixed stand, high accuracy, inconvenient operation
4786-2	$\varnothing 24-64\text{mm}$	$\varnothing 2-70\text{mm}$	universal stand, low accuracy, convenient operation

## QUICK POSITIONING CONCENTRICITY GAGES

QUICK-POSITIONING, SUITABLE FOR MASS MEASUREMENT

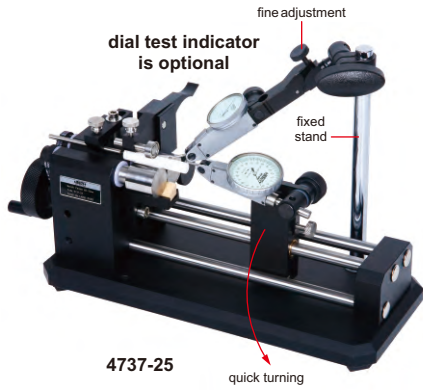

4737-25

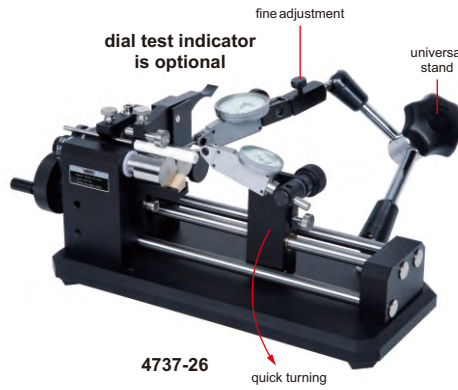

4737-26



standard rod (included)

to ensure the accuracy 2 $\mu$ m, the distance between measuring point and roller should be <30mm

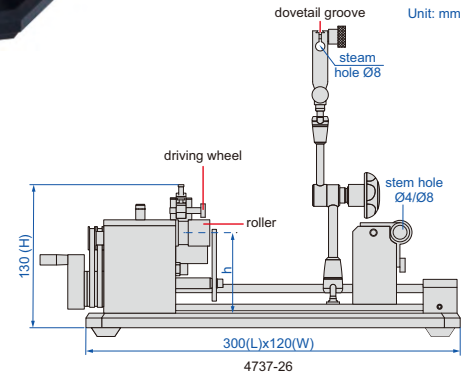
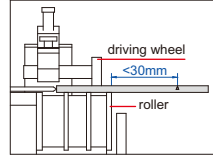

- Quick positioning, suitable for mass measurement
- Supplied with standard rod to verify accuracy
- Optional accessory: dial test indicators

Code	Diameter range	Workpiece length	Accuracy	Center height (h)	L×W×H	Weight	Remark
4737-25	Ø3-25mm	15-100mm	2 $\mu$ m	70mm	267×114×130mm	3kg	fixed stand, high accuracy, inconvenient operation
4737-26	Ø3-25mm	15-100mm	2 $\mu$ m	70mm	267×114×130mm	3kg	universal stand, low accuracy, convenient operation

## MINI BENCH CENTER

- Distance between two centers (D): 35-100mm
- Diameter of center (Ød): 6mm
- Taper of center: MT1



4721-75A

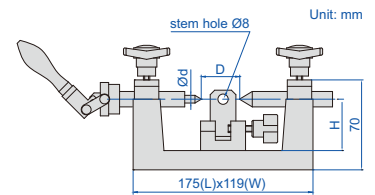

Code	Runout accuracy	Center height (H)	Weight	Load
4721-75A	2 $\mu$ m	40mm	4.5kg	4kg

## BENCH CENTER (BASIC TYPE)

- Distance between two centers: 300mm
- Hardened cast-iron guide surface
- Movable column
- V-slot for cylinder Ø4~Ø22mm

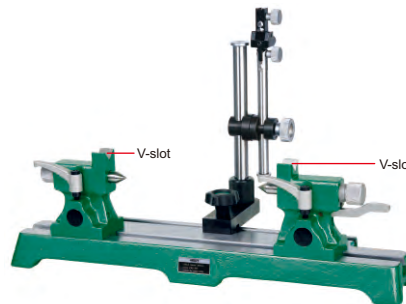

4782-300

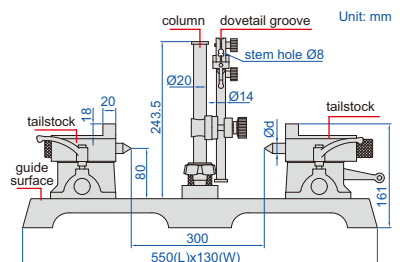

Code	Parallelism*	Runout accuracy	Center height	Diameter of center (Ød)	Load
4782-300	0.01mm	2 $\mu$ m	80mm	Ø16mm	25kg

\*Parallelism of two centers to the guide surface

**BENCH CENTERS**

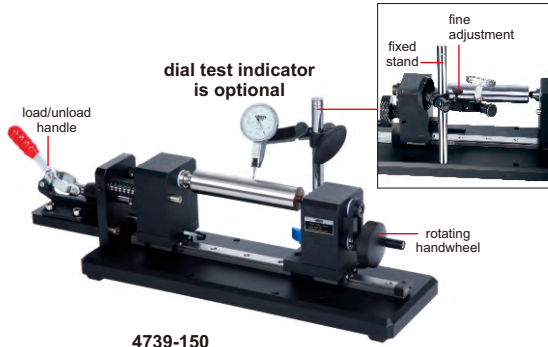

4739-150

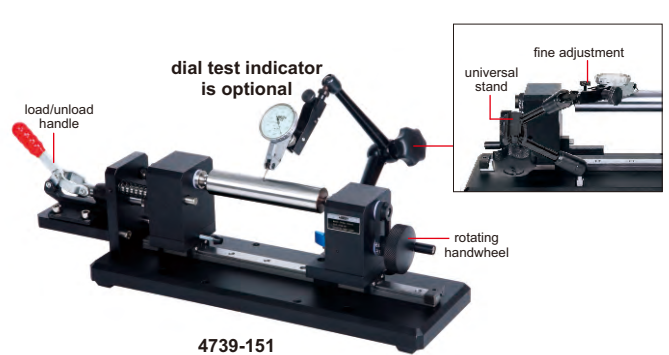

4739-151

**POPULAR MODEL**

- Quick positioning, suitable for mass measurement
- Suitable for cylinders with outside diameter  $\varnothing$ 3-140mm or inside diameter  $\varnothing$ 1-12mm
- Supplied with standard rod to verify accuracy
- Optional accessory: dial test indicators

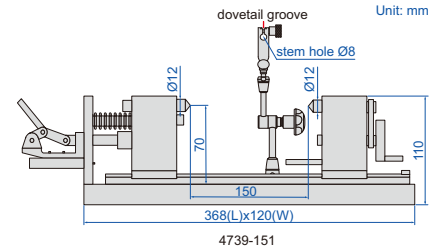

4739-151

Code	Center height	Distance between two centers	Runout accuracy	Weight	Load	Remark
4739-150	70mm	150mm	2 $\mu$ m	6.5kg	15kg	fixed stand, high accuracy, inconvenient operation
4739-151	70mm	150mm	2 $\mu$ m	6.5kg	15kg	universal stand, low accuracy, convenient operation

**BENCH CENTERS**

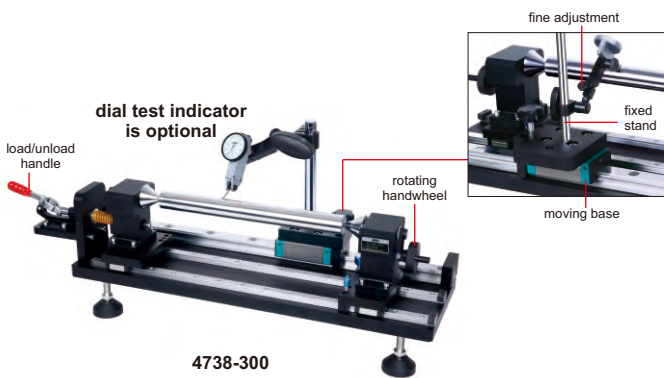

4738-300

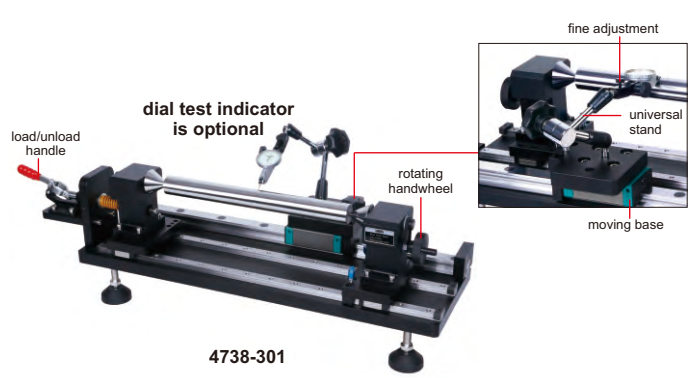

4738-301

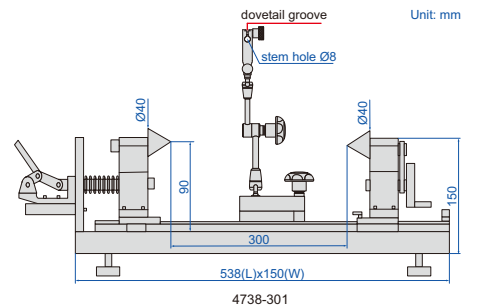
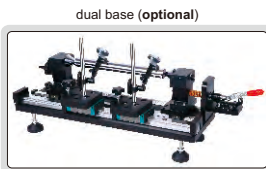

4738-301

- Quick positioning, suitable for mass measurement
- Suitable for cylinders with outside diameter  $\varnothing$ 3-180mm or inside diameter  $\varnothing$ 1-40mm
- Supplied with standard rod to verify accuracy
- Optional accessory: dial test indicators

Code	Center height	Distance between two centers	Runout accuracy	Weight	Load	Remark
4738-300	90mm	300mm	2 $\mu$ m	15kg	20kg	fixed stand, high accuracy, inconvenient operation
4738-301	90mm	300mm	2 $\mu$ m	15kg	20kg	universal stand, low accuracy, convenient operation

## BENCH CENTERS



- Accuracy: 2µm
- Quick positioning, suitable for mass measurement
- 4741-40 optional accessory: dial test indicators (code 2880-02, 2880-02R)
- 4741-41 optional accessory: high precision digital indicators (code 2140-6, 2140-6WL)



4741-40

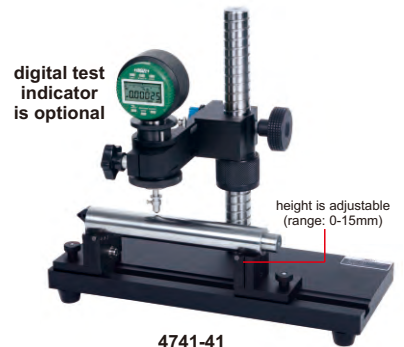

4741-41

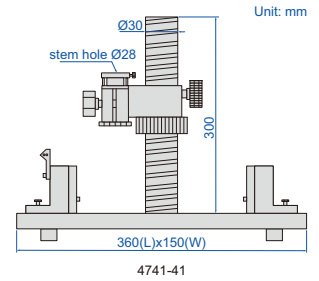
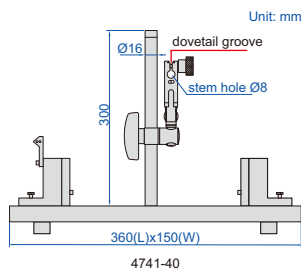

Code	Stem hole	Diameter range	Workpiece length
4741-40	Ø8mm	Ø3-40mm	15-300mm
4741-41	Ø28mm	Ø3-40mm	15-300mm

## VERTICAL BENCH CENTER

- Runout accuracy: 2µm
- Distance between two centers (L): 360mm
- Diameter of center (Ød): 24.1mm
- Taper of center: MT3
- Hardened cast-iron guide surface
- Use handwheel to move the tailstock
- Optional accessory: magnetic stands, dial test indicators

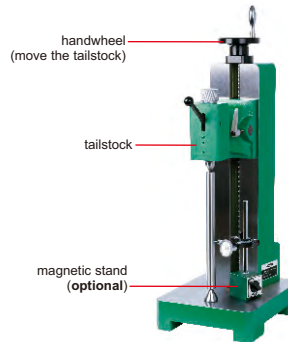

4728-360

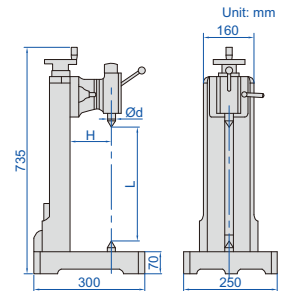

Code	Parallelism*	Center height (H)	Weight	Load
4728-360	0.01mm	130mm	85kg	80kg

\*Parallelism of two centers to the guide surface

## SHANK RUNOUT TESTERS

standard shank (included)



4771-30

- Measure the radial runout of shanks, collets and cutting tools
- Optional accessory: dial test indicators, magnetic stands

Code	Taper	Accuracy
4771-30	BT30	1µm
4771-40	BT40	1µm
4771-50	BT50	1µm

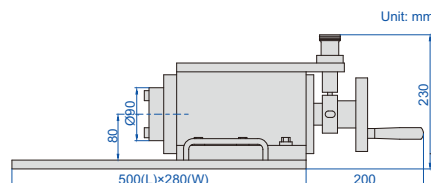

measure radial runout of shank

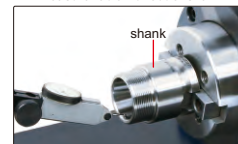

measure radial runout of collet

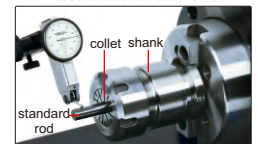

measure radial runout of cutter

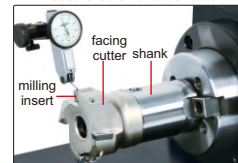

measure radial runout of end mill

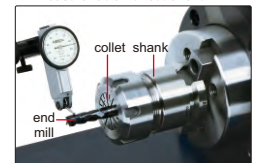

### FEELER GAGE



4601-25

- Range: 0.04-1.00mm
- Made of hardened alloy steel
- Meet DIN2275/grade TC1
- Accuracy:  $\pm(3+T/80)$   $\mu\text{m}$ , 'T' is the thickness of leaves in  $\mu\text{m}$

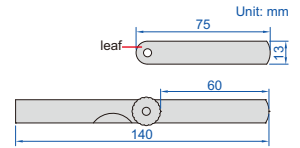

Code	Thickness of leaves included (mm)	Quantity of leaves
4601-25	0.04, 0.05, 0.06, 0.07, 0.08, 0.09, 0.10, 0.15, 0.20, 0.25, 0.30, 0.35, 0.40, 0.45, 0.50, 0.55, 0.60, 0.65, 0.70, 0.75, 0.80, 0.85, 0.90, 0.95, 1.00	25

### FEELER GAGES

- Made of hardened alloy steel
- Meet DIN2275/grade TC1
- Accuracy:  $\pm(3+T/80)$   $\mu\text{m}$ , 'T' is the thickness of leaves in  $\mu\text{m}$



4602-20

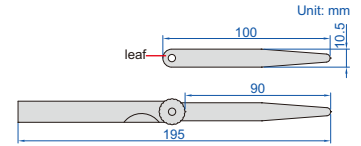

Code	Range	Thickness of leaves included (mm)	Quantity of leaves
4602-13A	0.03-0.50mm	0.03, 0.04, 0.05, 0.06, 0.07, 0.08, 0.09, 0.10, 0.15, 0.20, 0.30, 0.40, 0.50	13
4602-13	0.05-1.00mm	0.05, 0.10, 0.15, 0.20, 0.25, 0.30, 0.40, 0.50, 0.60, 0.70, 0.80, 0.90, 1.00	13
4602-17	0.02-1.00mm	0.02, 0.03, 0.04, 0.05, 0.06, 0.07, 0.08, 0.09, 0.10, 0.15, 0.20, 0.25, 0.30, 0.40, 0.50, 0.75, 1.00	17
4602-20	0.05-1.00mm	0.05, 0.10, 0.15, 0.20, 0.25, 0.30, 0.35, 0.40, 0.45, 0.50, 0.55, 0.60, 0.65, 0.70, 0.75, 0.80, 0.85, 0.90, 0.95, 1.00	20
4602-32	0.03-1.00mm	0.03, 0.04, 0.05, 0.06, 0.07, 0.08, 0.09, 0.10, 0.13, 0.15, 0.18, 0.20, 0.23, 0.25, 0.28, 0.30, 0.33, 0.35, 0.38, 0.40, 0.45, 0.50, 0.55, 0.60, 0.63, 0.65, 0.70, 0.75, 0.80, 0.85, 0.90, 1.00	32

### LONG FEELER GAGE

- Range: 0.05-1.00mm
- Made of hardened alloy steel
- Meet DIN2275/grade TC1
- Accuracy:  $\pm(3+T/80)$   $\mu\text{m}$ , 'T' is the thickness of leaves in  $\mu\text{m}$



4605-20

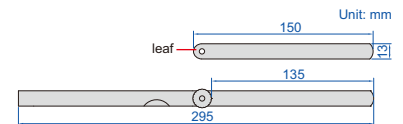

Code	Thickness of leaves included (mm)	Quantity of leaves
4605-20	0.05, 0.10, 0.15, 0.20, 0.25, 0.30, 0.35, 0.40, 0.45, 0.50, 0.55, 0.60, 0.65, 0.70, 0.75, 0.80, 0.85, 0.90, 0.95, 1.00	20

### PLASTIC FEELER GAGES

- Accuracy:  $\pm 0.04\text{mm}$  (thickness of leaves: 0.25mm)
- $\pm 0.05\text{mm}$  (thickness of leaves: 0.5mm)
- $\pm 0.08\text{mm}$  (thickness of leaves:  $\geq 1\text{mm}$ )

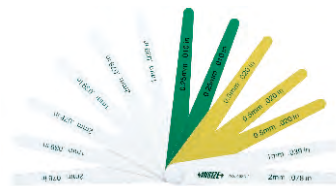

4623-2

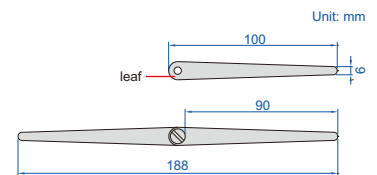

Code	Range	Thickness of leaves included	Quantity of leaves
4623-2	0.25-2.00mm	2.00mm (0.078"), 1.00mm (0.039"), 0.50mm (0.020"), 0.50mm (0.020"), 0.50mm (0.020"), 0.25mm (0.010"), 0.25mm (0.010"), 1.00mm (0.039"), 2.00mm (0.078"), 1.00mm (0.039"), 2.00mm (0.078"), 1.00mm (0.039"), 2.00mm (0.078")	13
4623-5	0.25-5.00mm	1.00mm (0.039"), 0.25mm (0.010"), 0.50mm (0.020"), 1.50mm (0.059"), 2.00mm (0.078"), 2.50mm (0.098"), 3.00mm (0.118"), 3.50mm (0.138"), 4.00mm (0.157"), 4.50mm (0.177"), 5.00mm (0.196")	11

### PLASTIC FEELER GAGE

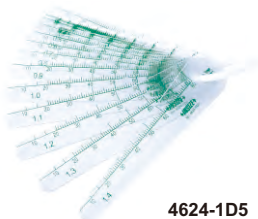

4624-1D5

- Accuracy:  $\pm 0.02\text{mm}$  (thickness of leaves: 0.05-0.1mm)
- $\pm 0.03\text{mm}$  (thickness of leaves: 0.15-0.6mm)
- $\pm 0.04\text{mm}$  (thickness of leaves:  $\geq 0.7\text{mm}$ )

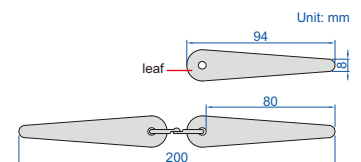

Code	Range	Thickness of leaves included (mm)	Quantity of leaves
4624-1D5	0.05-1.5mm	0.05, 0.1, 0.15, 0.2, 0.3, 0.4, 0.5, 0.6, 0.7, 0.8, 0.9, 1.0, 1.1, 1.2, 1.3, 1.4, 1.5	17



## FEELER GAGE ROLLS

- Used as shims to accurately set spacing
- Made of hardened alloy steel
- Length 5m
- Width 13mm



4621-30

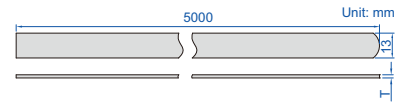

Code	Thickness (T)	Accuracy	Code	Thickness (T)	Accuracy	Code	Thickness (T)	Accuracy
4621-02	0.02mm	±4µm	4621-12	0.12mm	±5µm	4621-50	0.50mm	±14µm
4621-03	0.03mm	±4µm	4621-15	0.15mm	±6µm	4621-55	0.55mm	±14µm
4621-04	0.04mm	±4µm	4621-18	0.18mm	±7µm	4621-60	0.60mm	±14µm
4621-05	0.05mm	±4µm	4621-20	0.20mm	±8µm	4621-65	0.65mm	±14µm
4621-06	0.06mm	±4µm	4621-25	0.25mm	±9µm	4621-70	0.70mm	±17µm
4621-07	0.07mm	±5µm	4621-30	0.30mm	±9µm	4621-75	0.75mm	±17µm
4621-08	0.08mm	±5µm	4621-35	0.35mm	±11µm	4621-80	0.80mm	±19µm
4621-09	0.09mm	±5µm	4621-40	0.40mm	±12µm	4621-90	0.90mm	±22µm
4621-10	0.10mm	±5µm	4621-45	0.45mm	±12µm			

## PITCH GAGES

- Identify the pitch of screw thread
- Made of medium carbon steel



4820-124

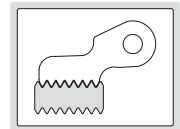

### Metric 60° screw

Code	Range	Pitch of leaves included	Quantity of leaves
4820-124	0.25-7mm	0.25, 0.3, 0.35, 0.4, 0.5, 0.7, 0.75, 0.8, 0.9, 1, 1.25, 1.5, 1.75, 2, 2.5, 3, 3.5, 4, 4.5, 5, 5.5, 6, 6.5, 7mm	24

### Unified 60° screw

Code	Range	Pitch of leaves included	Quantity of leaves
4820-230	4-42TPI	4, 4-1/2, 5, 5-1/2, 6, 7, 8, 9, 10, 11, 11-1/2, 12, 13, 14, 15, 16, 18, 20, 22, 24, 26, 27, 28, 30, 32, 34, 36, 38, 40, 42TPI	30

### Metric 60° and Whitworth 55° screw

Code	Range	Pitch of leaves included	Quantity of leaves
4820-452	0.25-6mm	0.25, 0.3, 0.35, 0.4, 0.45, 0.5, 0.6, 0.7, 0.75, 0.8, 0.9, 1, 1.25, 1.5, 1.75, 2, 2.5, 3, 3.5, 4, 4.5, 5, 5.5, 6mm	52
	4-62TPI	4, 4-1/2, 5, 6, 7, 8, 9, 10, 11, 12, 13, 14, 16, 18, 19, 20, 22, 24, 25, 26, 28, 30, 32, 36, 40, 48, 60, 62TPI	

### Metric 60° and Unified 60° screw

Code	Range	Pitch of leaves included	Quantity of leaves
4820-552	0.4-7mm	0.4, 0.5, 0.6, 0.7, 0.75, 0.8, 0.9, 1, 1.25, 1.5, 1.75, 2, 2.5, 3, 3.5, 4, 4.5, 5, 5.5, 6, 6.5, 7mm	52
	4-42TPI	4, 4-1/2, 5, 5-1/2, 6, 7, 8, 9, 10, 11, 11-1/2, 12, 13, 14, 15, 16, 18, 20, 22, 24, 26, 27, 28, 30, 32, 34, 36, 38, 40, 42TPI	

## PITCH GAGE

- Accuracy: ±0.07mm
- Check the pitch of screw thread
- Made of medium carbon steel



4824-12

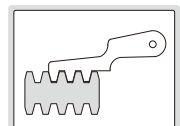

Code	Range	Thread type	Pitch of leaves included	Quantity of leaves
4824-12	2-20mm	Tr30°	2, 3, 4, 5, 6, 7, 8, 9, 10, 12, 16, 20mm	12

## GEAR TOOTH PITCH GAGES

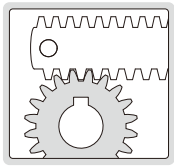

4860-245

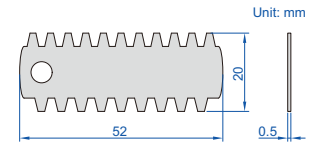

- Accuracy:  $\pm 0.05\text{mm}$
- Check the module pitch of gear tooth
- Made of hardened stainless steel

Code	Range	Pressure angle	Quantity of leaves
4860-145	0.35-4.5mm	14.5°	15
4860-245	0.35-4.5mm	20°	15
4860-112	5-12mm	14.5°	8
4860-212	5-12mm	20°	8

## CENTER GAGES



4810-601

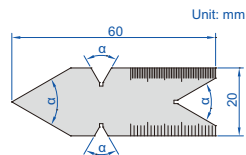

- To check and set screw cutting tools, and check the angle and pitch of screw thread
- Angle accuracy:  $\pm 30\text{min}$ .
- Made of stainless steel

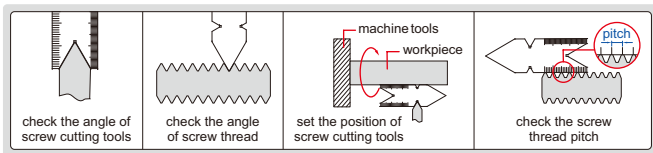

Code	Thread type	Angle ( $\alpha$ )	Graduation
4810-601	METRIC 60°	60°	0.5mm and 1mm
4810-55	WHITWORTH 55°	55°	14ths and 20ths on front side, 24ths and 32ths on back side

## THREAD GAGES



4812-E

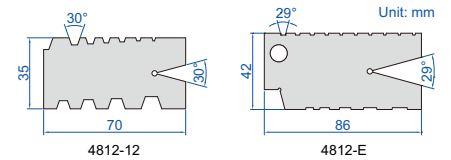

- To check and set screw cutting tools
- Made of medium carbon steel

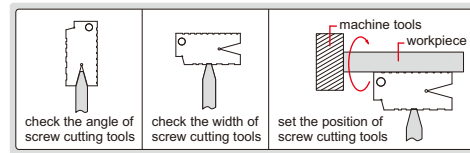

Code	Range	Thread type	Pitch
4812-12	2-12mm	Tr 30°	2, 3, 4, 5, 6, 7, 8, 9, 10, 12mm
4812-E	1-10TPI	ACME 29°	1, 1-1/3, 1-1/2, 1-3/4, 2, 2-1/2, 3, 4, 5, 6, 7, 8, 9, 10TPI

## ANGLE GAGE SET

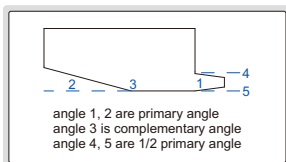

type A

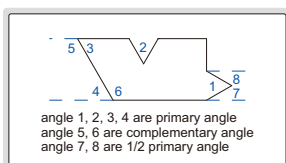

type B



4807

- Each blade checks primary, 1/2 primary and complementary angles
- Made of medium carbon steel

Code	Quantity of leaves	Accuracy
4807	18	$\pm 10'$

Primary angle	1/2 primary angle	Complementary angle	Type
5°	2°30'	175°	A
10°	5°	170°	A
15°	7°30'	165°	A
20°	10°	160°	B
25°	12°30'	155°	B
30°	15°	150°	B
35°	17°30'	145°	B
40°	20°	140°	B
45°	22°30'	135°	B
50°	25°	130°	B
55°	27°30'	125°	B
60°	30°	120°	B
65°	32°30'	115°	B
70°	35°	110°	B
75°	37°30'	105°	B
80°	40°	100°	B
85°	42°30'	95°	B
90°	45°	90°	B

## ANGLE GAGE

- Accuracy:  $\pm 30'$
- To check complementary angles
- Made of stainless steel



4806-20

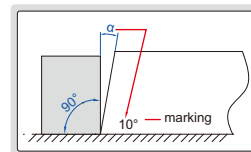

Code	Range ( $\alpha$ )	Angle of leaves included	Quantity of leaves
4806-20	1°-45°	1°, 2°, 3°, 4°, 5°, 6°, 7°, 8°, 9°, 10°, 12°, 14°, 16°, 18°, 20°, 25°, 30°, 35°, 40°, 45°	20

## RADIUS GAGES

- Made of medium carbon steel



4801-17

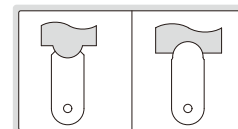

Code	Range	Radius of leaves included (mm)	Quantity of leaves (internal+external)
4801-17	1-7mm	1, 1.25, 1.5, 1.75, 2, 2.25, 2.5, 2.75, 3, 3.5, 4, 4.5, 5, 5.5, 6, 6.5, 7	17+17
4801-16	7.5-15mm	7.5, 8, 8.5, 9, 9.5, 10, 10.5, 11, 11.5, 12, 12.5, 13, 13.5, 14, 14.5, 15	16+16
4801-15	15.5-25mm	15.5, 16, 16.5, 17, 17.5, 18, 18.5, 19, 19.5, 20, 21, 22, 23, 24, 25	15+15

## RADIUS GAGE

- Made of stainless steel



4802-31

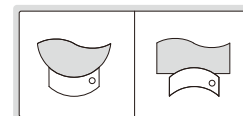

Code	Range	Radius of leaves included (mm)	Quantity of leaves
4802-31	25-40mm	25, 25.5, 26, 26.5, 27, 27.5, 28, 28.5, 29, 29.5, 30, 30.5, 31, 31.5, 32, 32.5, 33, 33.5, 34, 34.5, 35, 35.5, 36, 36.5, 37, 37.5, 38, 38.5, 39, 39.5, 40	31

## RADIUS GAGE SET

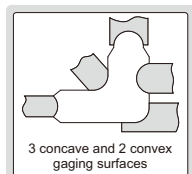

- Each piece has 3 concave and 2 convex gaging surfaces
- Supplied with handle
- Made of medium carbon steel



4804-26

Code	Range	Radius of leaves included (mm)	Quantity of leaves
4804-26	0.5-13mm	0.5, 1, 1.5, 2, 2.5, 3, 3.5, 4, 4.5, 5, 5.5, 6, 6.5, 7, 7.5, 8, 8.5, 9, 9.5, 10, 10.5, 11, 11.5, 12, 12.5, 13	26

## DRILL POINT GAGE



4843-1

- For twist drills with 118° angle, to check if the center of tip is concentric with the drill body
- Made of stainless steel

Code	Accuracy	
	Angle	Length
4843-1	$\pm 0.5^\circ$	$\pm 0.5\text{mm}$

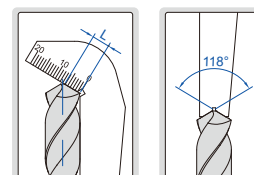

### DRILL ANGLE GAGE



4842-1

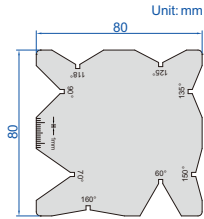

- Check drills with angle 60°, 70°, 90°, 118°, 125°, 135°, 150° or 160°
- Made of stainless steel

Code	Accuracy
4842-1	±0.5°

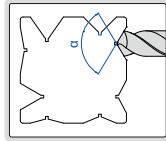

### ANGLE GAGE



4854-1

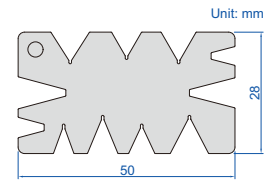

- Accuracy: ±10'
- Made of stainless steel

Code	Range
4854-1	29°, 30°, 40°, 45°, 50°, 55°, 60°

check the angle of screw cutting tools

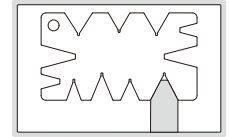

### U.S. STANDARD SHEET METAL GAGE

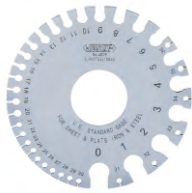

4809

No.	W	No.	W
0	7.938mm/0.3125"	18	1.270mm/0.0500"
1	7.144mm/0.2813"	19	1.111mm/0.0438"
2	6.747mm/0.2656"	20	0.953mm/0.0375"
3	6.350mm/0.2500"	21	0.873mm/0.0344"
4	5.953mm/0.2344"	22	0.794mm/0.0313"
5	5.556mm/0.2188"	23	0.714mm/0.0281"
6	5.159mm/0.2031"	24	0.635mm/0.0250"
7	4.763mm/0.1875"	25	0.556mm/0.0219"
8	4.366mm/0.1719"	26	0.476mm/0.0188"
9	3.969mm/0.1563"	27	0.437mm/0.0172"
10	3.572mm/0.1406"	28	0.397mm/0.0156"
11	3.175mm/0.1250"	29	0.357mm/0.0141"
12	2.778mm/0.1094"	30	0.318mm/0.0125"
13	2.381mm/0.0938"	31	0.278mm/0.0109"
14	1.984mm/0.0781"	32	0.258mm/0.0102"
15	1.786mm/0.0703"	33	0.238mm/0.0094"
16	1.588mm/0.0625"	34	0.218mm/0.0086"
17	1.429mm/0.0563"	35	0.198mm/0.0078"
		36	0.179mm/0.0070"

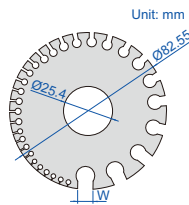

- For gaging sheet metal, plate iron and steel
- Hardened to HRC50-57

Code	Range
4809	0-36 (7.938-0.179mm/0.3125-0.0070")

### AMERICAN STANDARD WIRE GAGE



4808

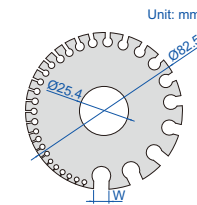

No.	W	No.	W
0	8.250mm/0.3249"	18	1.020mm/0.0403"
1	7.350mm/0.2893"	19	0.912mm/0.0359"
2	6.540mm/0.2576"	20	0.813mm/0.0320"
3	5.830mm/0.2294"	21	0.724mm/0.0285"
4	5.190mm/0.2043"	22	0.643mm/0.0253"
5	4.620mm/0.1819"	23	0.574mm/0.0226"
6	4.110mm/0.1620"	24	0.511mm/0.0201"
7	3.670mm/0.1443"	25	0.440mm/0.0179"
8	3.260mm/0.1285"	26	0.404mm/0.0159"
9	2.910mm/0.1144"	27	0.361mm/0.0142"
10	2.590mm/0.1019"	28	0.320mm/0.0126"
11	2.300mm/0.0907"	29	0.287mm/0.0113"
12	2.050mm/0.0808"	30	0.254mm/0.0100"
13	1.820mm/0.0720"	31	0.226mm/0.0089"
14	1.630mm/0.0641"	32	0.203mm/0.0080"
15	1.450mm/0.0571"	33	0.180mm/0.0071"
16	1.290mm/0.0508"	34	0.160mm/0.0063"
17	1.150mm/0.0453"	35	0.142mm/0.0056"
		36	0.127mm/0.0050"

- For gaging non-ferrous wire and metals such as copper, brass and aluminum
- Hardened to HRC50-57

Code	Range
4808	0-36 (8.250-0.127mm/0.3249-0.0050")

### WIRE GAGE

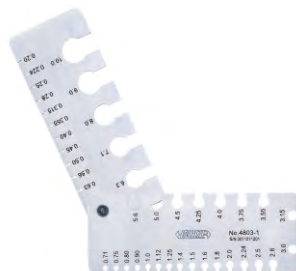
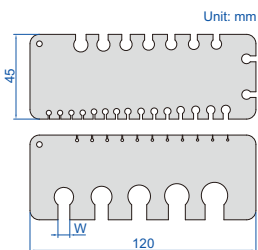

4803-1

- For gaging non-ferrous wire and metals such as copper, brass and aluminum
- Hardened to HRC51-53
- Including 2 pcs wire gages

Code	Range
4803-1	0.2-10mm

Wire diameter (W)	Wire diameter (W)	Wire diameter (W)
0.200mm	0.900mm	3.55mm
0.224mm	1.000mm	3.75mm
0.250mm	1.120mm	4.00mm
0.280mm	1.250mm	4.25mm
0.315mm	1.400mm	4.50mm
0.355mm	1.500mm	5.00mm
0.400mm	1.60mm	5.60mm
0.450mm	1.80mm	6.30mm
0.500mm	2.00mm	7.10mm
0.560mm	2.24mm	8.00mm
0.630mm	2.50mm	9.00mm
0.710mm	2.80mm	10.00mm
0.750mm	3.00mm	
0.800mm	3.15mm	

## THICKNESS GAGE

- Made of stainless steel

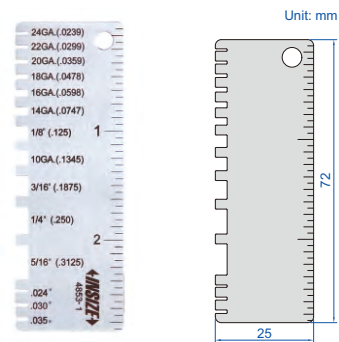
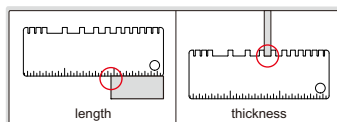

4853-1

Code	Measurement	Range	Graduation	Accuracy
4853-1	length	0-2 3/4"	1/16"	1/32"
	thickness	24GA. (0.0239"), 22GA. (0.0299"), 20GA.(0.0359")	—	±0.002"
		18GA. (0.0478"), 16GA. (0.0598"), 14GA. (0.0747"), 1/8" (0.125"), 10GA. (0.1345"), 3/16" (0.1875"), 1/4" (0.250"), 5/16" (0.3125")		±0.004"
		0.024", 0.030", 0.035"		±0.002"

## DIGITAL TAPER SLOT GAGES

- Non waterproof
- Accuracy: ±0.03mm
- Measuring opening, slot width
- Resolution: 0.01mm/0.0005"
- Buttons: on/off, zero, mm/inch
- Automatic power off, move the digital unit to turn on power
- Battery CR2032, data output
- Made of stainless steel
- Optional accessory: data output cable (code 7315-21 need receiver, 7302-21)

DIRECT READING,  
CALCULATION IS NOT REQUIRED

DATA  
OUTPUT



1160-10

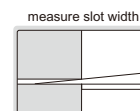
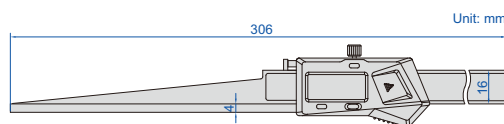

Code	Range
1160-10	0.2-10mm/0.01-0.39"

## TAPER SLOT GAGES

- For quick measurement of slot width
- Satin chrome plated reading surface
- Made of stainless steel

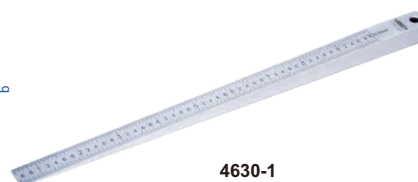
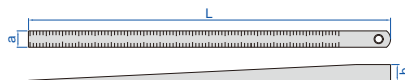

4630-1

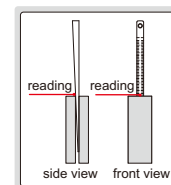

Code	Range	Graduation	Accuracy	L	a	b
4630-3	0.4-6mm	0.05mm	±0.04mm	164mm	12.5mm	6.5mm
4630-1	0.5-10mm	0.05mm	±0.07mm	220mm	10mm	10.5mm
4630-2	0.5-15mm	0.1mm	±0.08mm	184mm	12.5mm	16.5mm

## TAPER GAGES

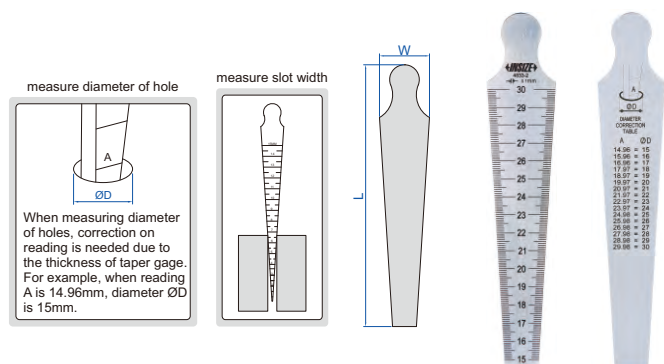

- Measure opening, slot width, hole diameter, etc.
- Diameter correction table on the back (only for 4833-1, 4833-2)
- Made of stainless steel

Code	Range	Accuracy	Graduation	L	W
4833-1	0.8-15mm	±0.05mm	0.1mm	146mm	17mm
4833-2	15-30mm	±0.05mm	0.1mm	159mm	30.4mm
4833-3	30-45mm	±0.05mm	0.1mm	166mm	45.4mm
4833-4	45-60mm	±0.05mm	0.1mm	170mm	60.5mm

## TAPER GAGE SET

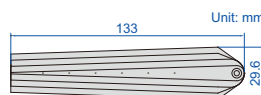

- Accuracy: ±0.05mm
- Include 4 pcs (1-8mm, 8-15mm, 15-22mm, 22-29mm)
- Measure opening, slot width, hole diameter, etc.
- Diameter correction table on the back
- Made of stainless steel

Code	Range	Graduation
4837-1	1-29mm	0.05mm

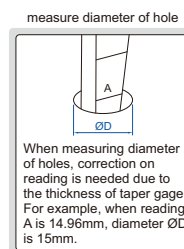

**SMALL TAPER BORE GAGE**

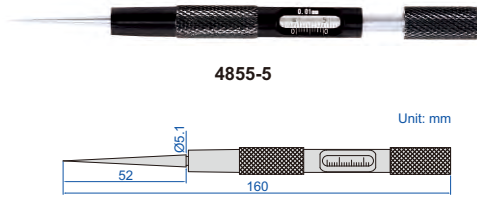

4855-5

Unit: mm

- Quick measurement of small bore diameter
- Hardened working face
- Supplied with protection cap

Code	Range	Graduation	Accuracy
4855-5	0.1-5mm	0.01mm	±0.03mm



**TAPER BORE GAGES**



4852-15

(mm)

Code	Range	L	Ød1	Ød2
4852-1	1-6.5mm	62.5	7	0.8
4852-3	3-16mm	143	17	2.8
4852-15	15-30mm	165	31	14.7
4852-30	30-45mm	165	46	29.6

- Graduation: 0.1mm
- Accuracy: ±0.05mm
- Quick measurement of bore diameter
- Hardened steel, HRC50-58
- Satin chrome plated surface
- Aluminium oxidized handle

**WELDING GAGE**

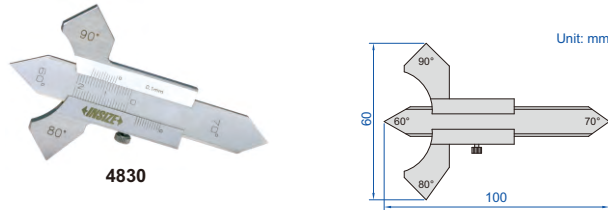

4830

Unit: mm

- Made of stainless steel
- Satin chrome plated reading surface

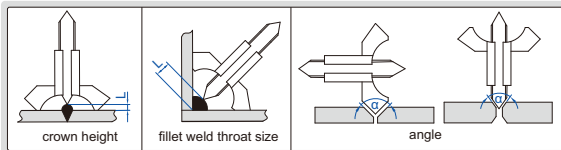

Code	Measurement	Range	Graduation	Accuracy
4830	crown height	0-8mm	0.1mm	±0.1mm
	fillet weld throat size	0-20mm	0.1mm	±0.3mm
	angle	60°, 70°, 80°, 90°	—	±1°

**DIGITAL WELDING GAGE**

ATTENTION:  
NO DATA OUTPUT

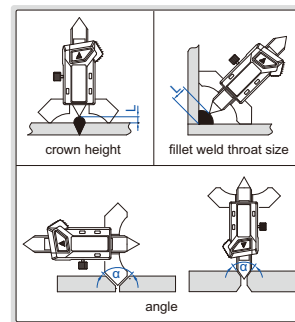

4831-20A

Unit: mm

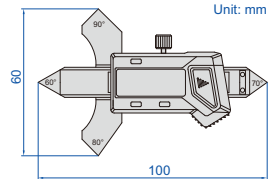

- Non waterproof
- Buttons: zero, mm/inch, on/off
- Battery LR44
- Made of stainless steel

Code	Measurement	Range	Resolution	Accuracy
4831-20A	crown height	0-7mm	0.01mm/0.0005"	±0.03mm
	fillet weld throat size	0-20mm	0.01mm/0.0005"	±0.1mm
	angle	60°, 70°, 80°, 90°	—	±1°

**FILLET WELDING GAGE**

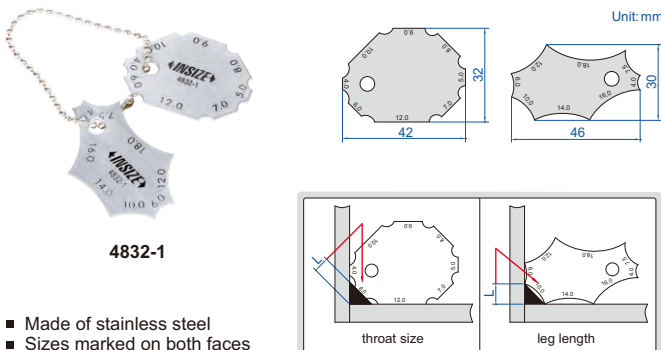

4832-1

Unit: mm

- Made of stainless steel
- Sizes marked on both faces

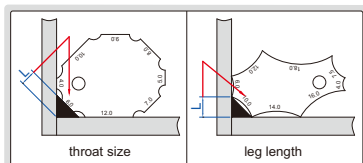

Code	Throat size (mm)	Leg length (mm)	Accuracy
4832-1	4, 5, 6, 7, 8, 9, 10, 12	4, 6, 7.5, 10, 12, 14, 16, 18	±0.5mm

**FILLET WELDING GAGE**

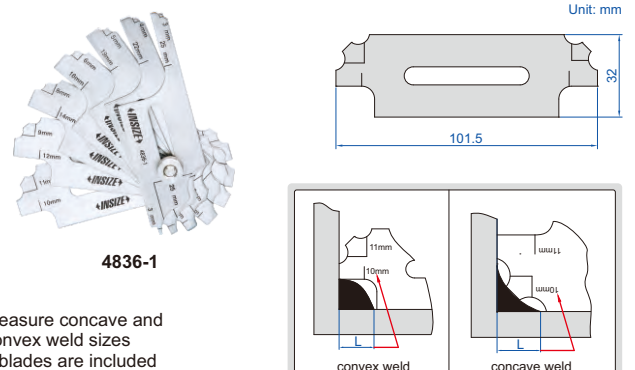

4836-1

Unit: mm

- Measure concave and convex weld sizes
- 7 blades are included
- Made of stainless steel

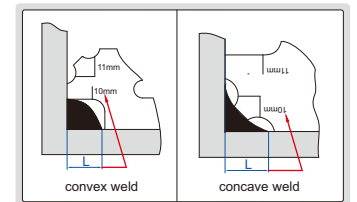

Code	Size (mm)	Accuracy
4836-1	3, 4, 5, 6, 8, 9, 10, 11, 12, 14, 16, 19, 22, 25	±0.5mm

### FILLET WELDING GAGE

- Measure convex weld sizes
- 3 blades are included
- Made of stainless steel

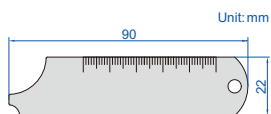

4847-1

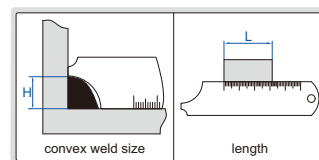

Code	Measurement	Range	Graduation	Accuracy
4847-1	convex weld size	4, 6, 8, 10, 12, 14mm	—	±0.5mm
	length	0-50mm	1mm	±0.5mm

### WELDING GAGE



4834-1

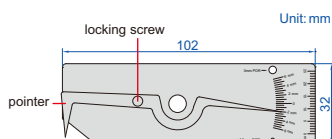

- Pointer can be locked for later reference
- Made of stainless steel

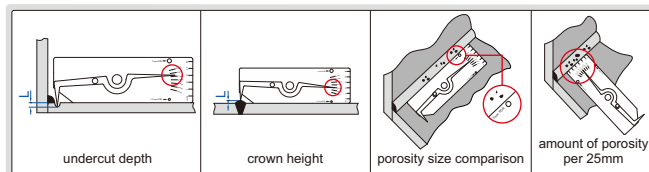

Code	Measurement	Range	Graduation	Accuracy
4834-1	undercut depth	0-6mm	0.5mm	±0.5mm
	crown height	0-6mm	0.5mm	±0.5mm
	porosity size comparison	1.5mm, 3mm	—	±0.2mm
	amount of porosity per 25mm	25mm	1mm	—

### WELDING GAGE

- Made of stainless steel

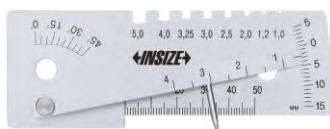
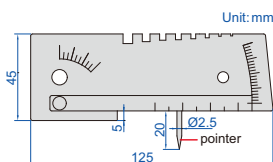

4848-1

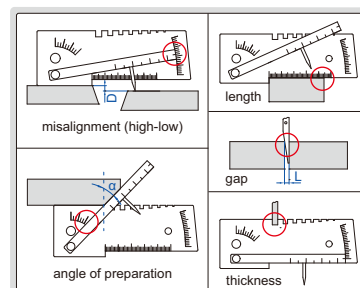

Code	Measurement	Range	Graduation	Accuracy
4848-1	misalignment (high-low)	-5mm~+15mm	1mm	±0.5mm
	angle of preparation	0°-45°	5°	±2.5°
	length	0-50mm	1mm	±0.5mm
	gap	1-4mm	0.5mm	±0.25mm
	thickness	1, 1.2, 2.0, 2.5, 3.0, 3.25, 4.0, 5.0mm	—	±0.1mm

### WELDING GAGE

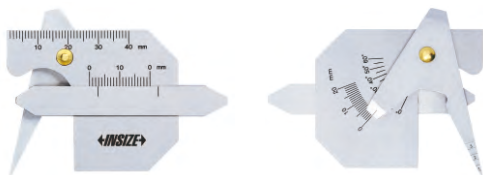
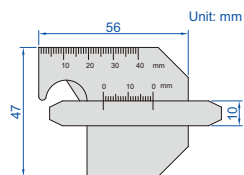

front

6832-1

back

- Made of stainless steel
- Satin chrome plated surface

Code	Measurement	Range	Graduation	Accuracy
6832-1	leg length	0-20mm	1mm	±0.3mm
	leg height	0-20mm	1mm	±0.3mm
	crown height	0-20mm	1mm	±0.3mm
	throat size	0-10mm	1mm	±0.3mm
	angle	0°-60°	5°	±1°
	gap	1-3.5mm	0.5mm	±0.2mm
	length	0-40mm	1mm	±0.3mm

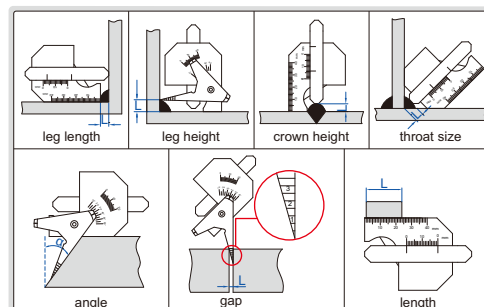

## WELDING GAGE

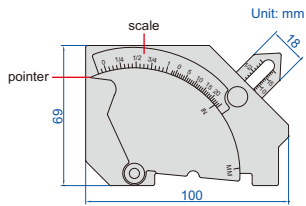

4835-1

- Adjustable scale to compensate pointer wear
- Made of stainless steel

Code	Measurement	Range	Graduation	Accuracy
4835-1	crown height	0-25mm (0-1")	1mm (1/16")	±0.5mm
	fillet weld leg height	0-25mm (0-1")	1mm (1/16")	±0.5mm
	misalignment (high-low)	0-25mm (0-1")	1mm (1/16")	±0.5mm
	undercut depth	0-2mm (0-1/8")	1mm (1/16")	±0.5mm
	fillet weld throat size	0-20mm (0-3/4")	1mm (1/16")	±0.5mm
	angle of preparation	0-60°	5°	±1°
	length	0-60mm (0-2")	1mm (1/16")	±0.5mm
	45° angle	—	—	±1°

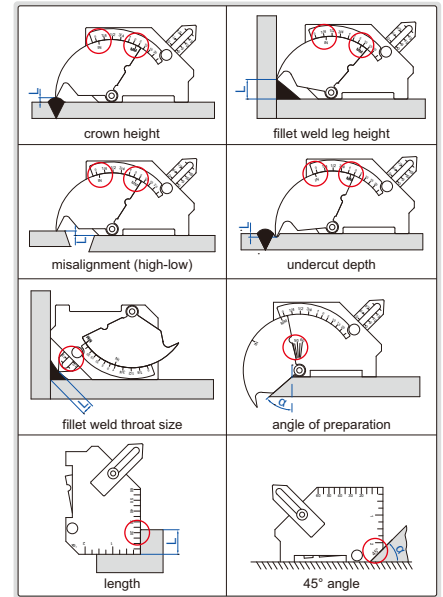

## WELDING GAGE

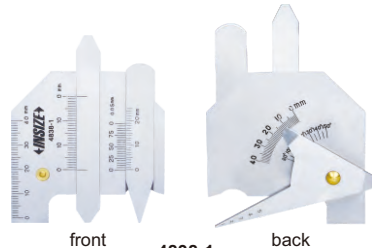
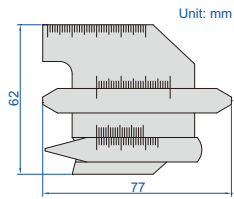

4838-1

- Made of stainless steel

Code	Measurement	Range	Graduation	Accuracy
4838-1	crown height	0-10mm	1mm	±0.5mm
	leg height	0-14mm	1mm	±0.5mm
	undercut depth	0-5mm	0.05mm	±0.05mm
	throat size	0-13mm	1mm	±0.5mm
	weld length	0-40mm	1mm	±1mm
	angle	90°-150°	5°	±1°
	gap	0.5-5mm	1mm	±0.5mm
	length	0-40mm	1mm	±0.5mm

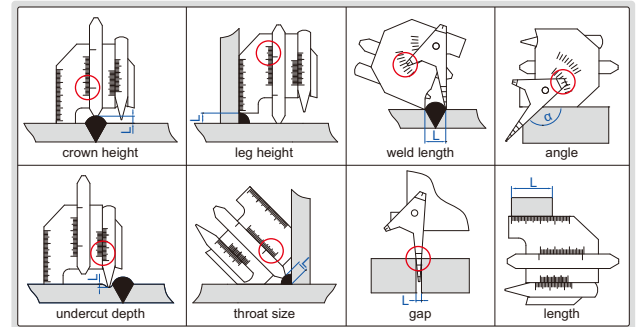

## WELDING UNDERCUT GAGE



4849-1

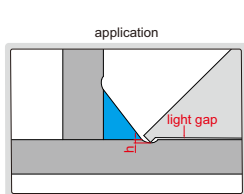

when there is a light gap,  $h < 0.25\text{mm}$ ;  
when there is no light gap,  $h \geq 0.25\text{mm}$

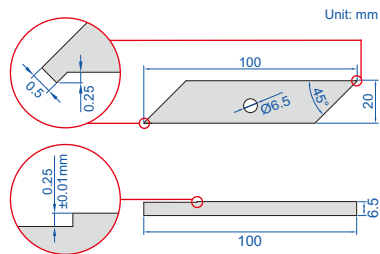

calibration block (included)



- Code 4849-1
- Measure undercut
- Calibration block is included
- Made of stainless steel

## WELDING GAGE

- Made of stainless steel



4850-1

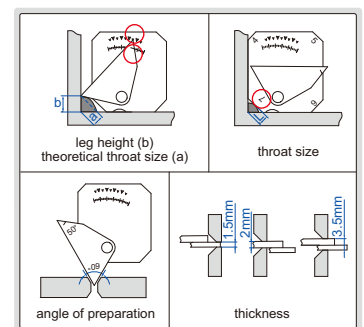
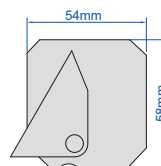

Code	Measurement	Range	Graduation	Accuracy
4850-1	leg height (b)	0-18mm	1mm	±0.5mm
	theoretical throat size (a)	2-12mm	1mm	±0.5mm
	throat size	4, 5, 6, 7mm	—	±0.5mm
	angle of preparation	50°, 60°	—	±1°
	thickness	1.5, 2, 3.5mm	—	±0.2mm



## FILLET WELDING GAGE

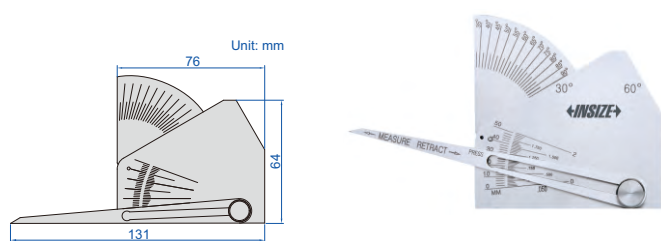

4846-1

- Calculating card is included
- Made of stainless steel

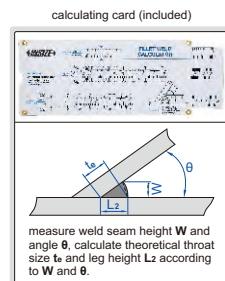
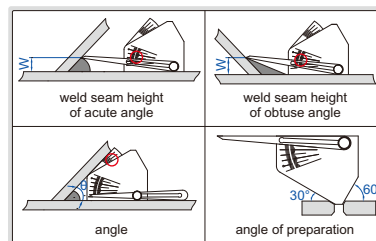

Code	Measurement	Range	Graduation	Accuracy
4846-1	weld seam height W	0-50mm/0-2"	2mm/0.05"	±1mm
	angle $\theta$	30°~90°	2.5°	±1°
	60° angle	—	—	±0.5°

## WELDING GAGE

- Accuracy: ±0.5mm
- Made of stainless steel

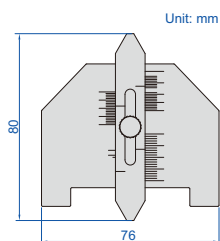

4851-1

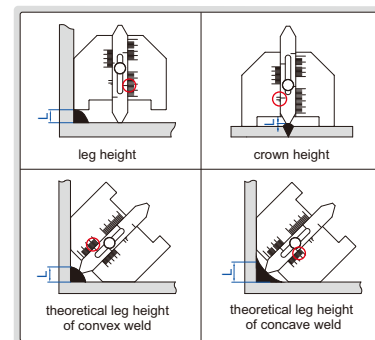

Code	Measurement	Range	Graduation
4851-1	leg height	0-20mm	1mm
	crown height	0-3mm	—
	theoretical leg height of convex weld	0-20mm	1mm
	theoretical leg height of concave weld	0-20mm	1mm

## WELDING GAGE

- Made of stainless steel

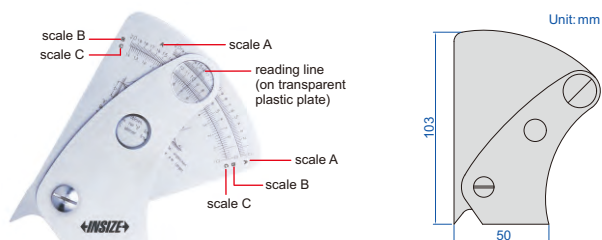

4840-1

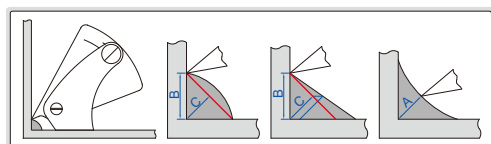

Code	Graduation	Accuracy
4840-1	0.2mm	±0.3mm

## PIPE WELDING GAGE

- Made of stainless steel

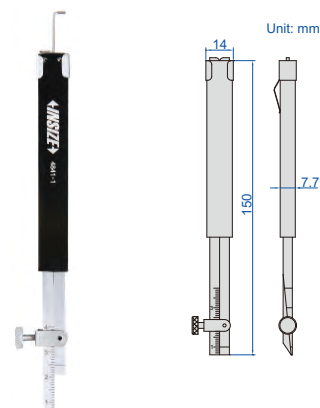

4841-1

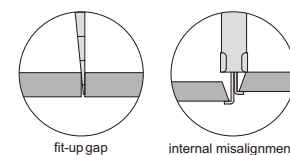

Code	Measurement	Range	Graduation	Accuracy
4841-1	internal misalignment	0-30mm	1mm	±0.5mm
	fit-up gap	0.7-4mm	0.1mm	±0.1mm

### PIPE WELDING GAGE

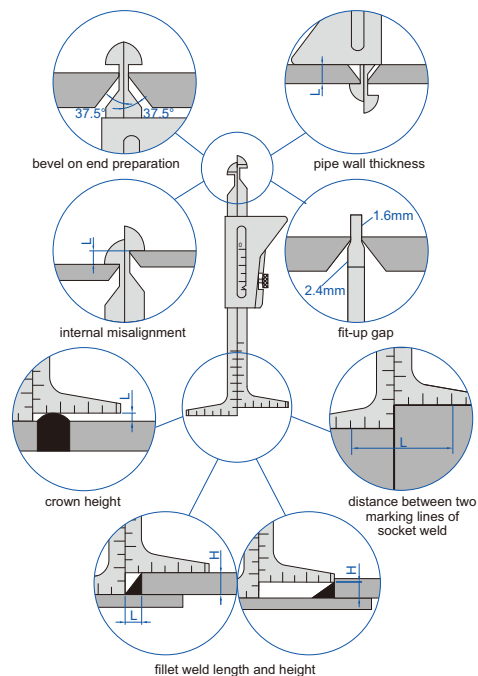
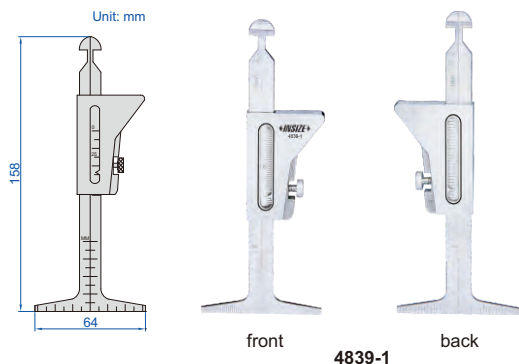

■ Made of stainless steel

Code	Measurement	Range	Graduation	Accuracy
4839-1	bevel on end preparation	37.5°	—	±1°
	pipe wall thickness	0-45mm (0~1-3/4")	1mm (1/16")	±0.5mm
	internal misalignment	0-35mm (0~1-3/8")	1mm (1/32")	±0.5mm
	fit-up gap	1.6mm, 2.4mm	—	±0.5mm
	crown height	0-35mm (0~1-3/8")	1mm (1/32")	±0.1mm
	distance between two marking lines of socket weld	0-60mm (0~2-3/8")	1mm (1/16")	±0.5mm
	fillet weld length	0-30mm (0~1-1/4")	1mm (1/16")	±0.5mm
fillet weld height	0-35mm (0~1-3/8")	1mm (1/32")	±0.5mm	

### 6-PIECE WELDING GAGE SET

- Includes:
  - 1) Welding gage (code 4834-1)
  - 2) Fillet welding gage, size 3~25mm, 7 blades (code 4836-1)
  - 3) Pipe welding gage (code 4841-1)
  - 4) Telescoping inspection mirror, size of mirror Ø32mm, length 178~505mm (code 7160-1)
  - 5) Pocket rule with sliding clip, range 150mm/6", graduation 1mm, 1/64" (code 7119-150)
  - 6) LED flashlight (code ISGF-0501)



5064

**Code**  
5064

### 7-PIECE WELDING GAGE SET

- Includes:
  - 1) Welding gage (code 4834-1)
  - 2) Welding gage (code 4851-1)
  - 3) Pipe welding gage (code 4839-1)
  - 4) Outside micrometer, range 0-25mm, graduation 0.01mm (code 3203-25A)
  - 5) Telescoping inspection mirror, size of mirror Ø32mm, length 178~505mm (code 7160-1)
  - 6) Magnifier with illumination, magnification 4X (code 7513-4)
  - 7) Steel rule, range 150mm/6", graduation 0.5mm, 1mm, 1/64", 1/32", 1/16" (code 7110-150)



5071

**Code**  
5071

### 7-PIECE WELDING GAGE SET

- Includes:
  - 1) Welding gage (code 4834-1)
  - 2) Welding gage (code 4851-1)
  - 3) Fillet welding gage, size 3~25mm, 7 blades (code 4836-1)
  - 4) Outside micrometer, range 0-25mm, graduation 0.01mm (code 3203-25A)
  - 5) Digital caliper, range 0-150mm/0-6", resolution 0.01mm/0.005" (code 1108-150)
  - 6) Pocket rule with sliding clip, range 150mm/6", graduation 1mm, 1/64" (code 7119-150)
  - 7) Magnifier with illumination, magnification 4X (code 7513-4)



5072

**Code**  
5072

### OUTSIDE SPRING CALIPERS

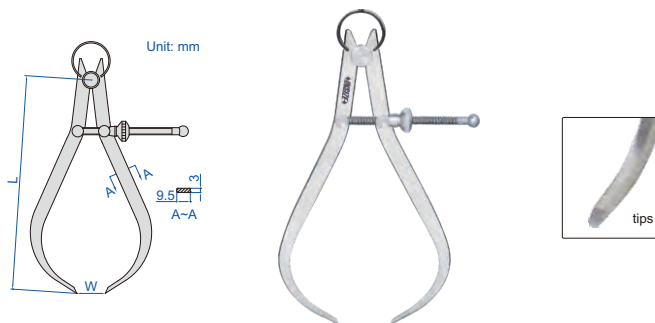

7262-150

Code	Size (L)	Range (W)
7262-150	155mm	0-140mm
7262-200	210mm	0-210mm
7262-250	265mm	0-270mm
7262-300	310mm	0-320mm

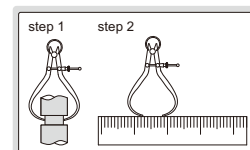

## INSIDE SPRING CALIPERS

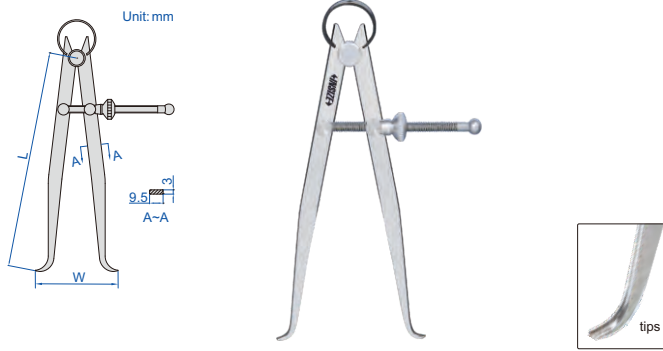

7261-150

- Made of carbon steel

Code	Size (L)	Range (W)
7261-150	150mm	20-170mm
7261-200	200mm	22-220mm
7261-300	300mm	30-320mm

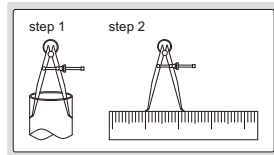

## SPRING DIVIDERS

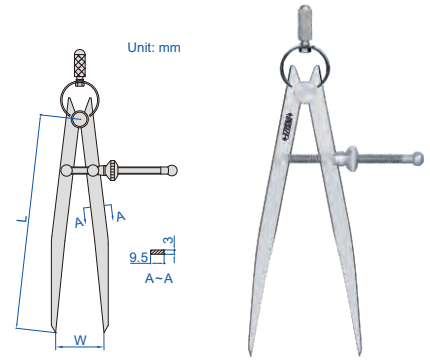
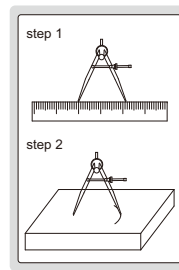

7260-150

- Made of carbon steel
- Hardened points

Code	Size (L)	Range (W)
7260-150	150mm	0-150mm
7260-200	200mm	0-210mm
7260-250	245mm	0-260mm
7260-300	300mm	0-320mm

## DIVIDERS

- Made of carbon steel
- Hardened points



7247-150

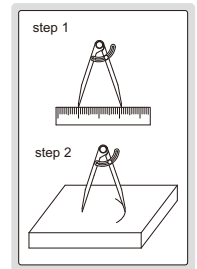
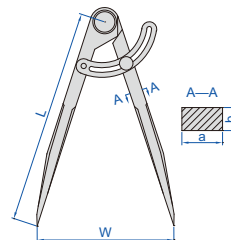

Code	Size (L)	Range (W)	(mm)	
			a	b
7247-150	150mm	0-140mm	8.5	7
7247-200	200mm	0-190mm	10	7
7247-300	300mm	0-290mm	12	7

## MEASURING TAPES

EG II

- Non-glare nylon surface for wear resistance
- Accuracy:  $\pm(0.3+0.2L)$ mm (L is the measured length rounded up to the next whole meter), meet MI-008 of DIRECTIVE 2014/32/EU



7140-5

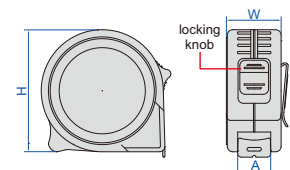
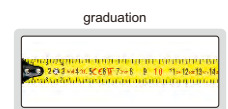

Code	Range	Graduation	Width of tape A	W	H
7140-3	0-3m	1mm	16mm	28mm	62mm
7140-5	0-5m	1mm	19mm	30mm	68mm
7140-8	0-8m	1mm	25mm	38mm	78mm

## MEASURING TAPE (BASIC TYPE)

EG II

- Non-glare nylon coating tape, wear resistance
- Accuracy:  $\pm(0.3+0.2L)$ mm (L is the measured length rounded up to the next whole meter), meet MI-008 of DIRECTIVE 2014/32/EU



7142-5

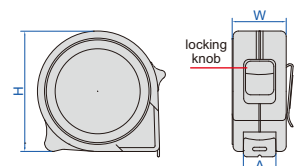
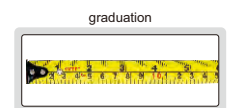

Code	Range	Graduation	Width of tape A	W	H
7142-5	0-5m/0-16ft	1mm, 1/16"	19mm	31mm	64mm

## WIRELESS DIGITAL MEASURING TAPES + LASER DISTANCE METERS



9563-C40

- Built-in bluetooth or wireless Zigbee transmission
- Display with backlight
- Automatic power off: laser 30s, main unit 180s
- Can work continuously for 5 hours
- Can store 50 groups of measurement data

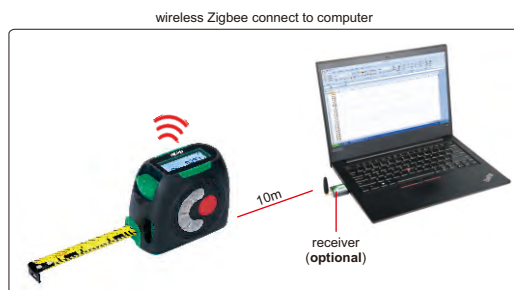
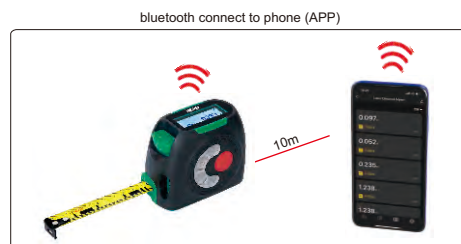

### SPECIFICATION

Code	9563-C40	9563-C60	9563-WL40	9563-WL60	
Output	bluetooth (data can be transmitted to APP)		wireless Zigbee (optional receiver required: code 7315-2/3/6/7/8/9) (data can be transmitted to excel, word, txt etc.)		
Digital measuring tape	range	5m			
	resolution	0.001m			
	accuracy	±1.5mm			
	blade width	19mm			
	horizontal stand-out	≥1.8m			
Laser distance meter	range	40m	60m	40m	60m
	resolution	0.001m			
	accuracy	±(3+D/20)mm, D: measured distance, unit: m			
	units	m, ft, in, ft+in			
	laser type	630~670nm, <1mW, class 2			
measurement function	single, continuous, area, volume, pythagoras measurement				
Operation temperature	0~40°C				
Storage temperature	-10~60°C				
Power supply	built-in rechargeable lithium battery				
Dimension (L×W×H)	95×74×56mm				
Weight	313g				

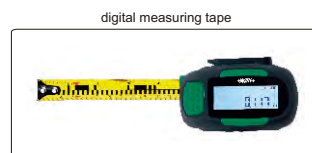

laser distance meter



## SELF ADHESIVE MEASURING TAPES



7139-50

- Self adhesive back
- Steel tape, non-glare coating, wear resistance

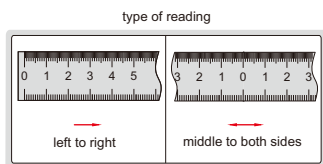
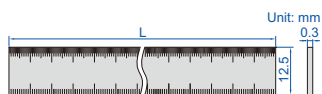

Code	Range (L)	Graduation	Accuracy	Type of reading
7139-50	50-0-50cm	1mm	±0.2mm	middle to both sides
7139-100	0-100cm	1mm	±0.4mm	left to right

## LONG MEASURING TAPE

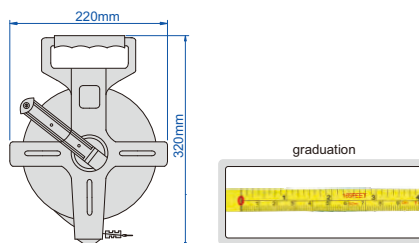

7143-50

- High tensile strength fiberglass tape
- Nylon coating tape, wear resistance
- Accuracy: ±(0.3+0.2L)mm (L is the measured length rounded up to the next whole meter), meet MI-008 of DIRECTIVE 2014/32/EU

Code	Range	Graduation	Width of tape
7143-50	0-50m/0-165ft	1mm, 1/8"	13mm

### MEASURING WHEEL (BASIC TYPE)

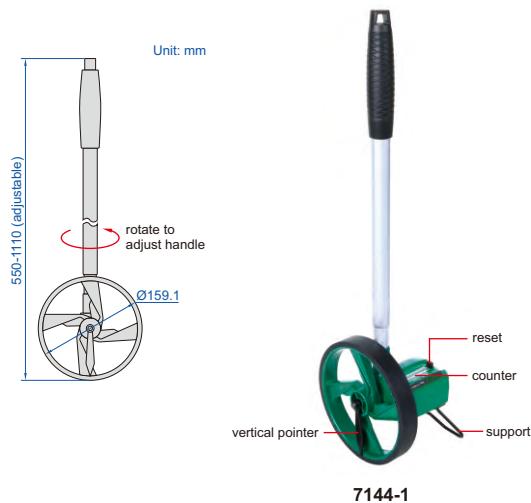

7144-1

- ABS plastic frame, wear-resistant PU tire
- Three-section adjustable handle

Code	Range	Resolution
7144-1	0.1-9999.9m	0.1m

### MEASURING WHEEL



7145-1

- ABS plastic frame, wear-resistant PU tire
- Two-section foldable handle

Code	Range	Resolution
7145-1	0.1-9999.9m	0.1m

### POCKET RULE WITH SLIDING CLIP

- Accuracy:  $\pm 0.30\text{mm}$
- With sliding clip, clip can be inserted in the pocket, also can be used as depth gage base
- Inch/metric conversion table on the back
- Made of stainless steel



7119-150

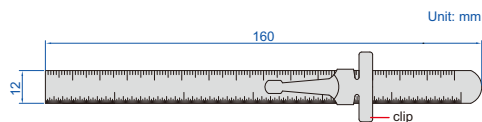

Code	Range	Graduation
7119-150	150mm/6"	1mm, 1/64"

### STEEL RULES

POPULAR MODEL



7110-300

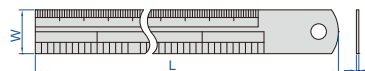

(mm)

Code	Range	Accuracy	L	W	H	Remark
7110-150	150mm/6"	$\pm 0.18\text{mm}$	170	18	1.0	graduation on front and back
7110-200	200mm/8"	$\pm 0.18\text{mm}$	220	18	1.0	graduation on front and back
7110-300	300mm/12"	$\pm 0.27\text{mm}$	330	25	1.0	graduation on front and back
7110-3001	300mm/12"	$\pm 0.27\text{mm}$	325	30	1.0	graduation on front and back
7110-500	500mm/20"	$\pm 0.40\text{mm}$	530	30	1.2	graduation on front and back
7110-600	600mm/24"	$\pm 0.50\text{mm}$	630	30	1.2	graduation on front and back
7110-1000	1000mm/40"	$\pm 0.50\text{mm}$	1040	32	1.5	graduation on front and back
7110-1500	1500mm/60"	$\pm 1.00\text{mm}$	1550	38	1.8	graduation on front
7110-2000	2000mm/80"	$\pm 1.00\text{mm}$	2065	40	2.0	graduation on front

- Graduation: 0.5mm, 1mm, 1/64", 1/32", 1/16"
- Rigid rules
- Made of stainless steel
- Non-glare surface

## TAPER GAGE AND STEEL RULER SET

use the taper gage to measure diameter of hole

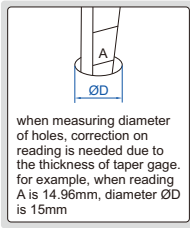

use the taper gage to measure slot width

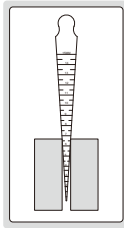

- Diameter correction table on the taper gage back
- Made of stainless steel

Code	Tool	Range	Graduation	Accuracy
4829-1	taper gage	0.8-15mm	0.1mm	±0.05mm
	steel ruler	150mm/6"	1.0mm	±0.18mm

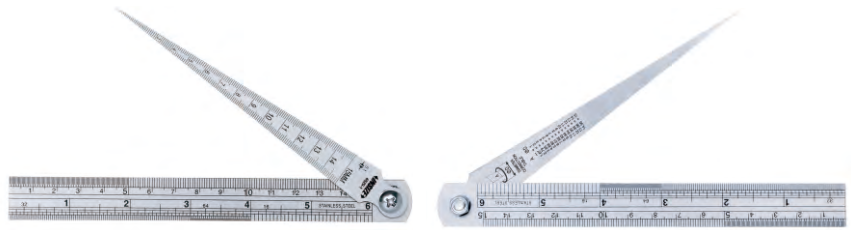

front

4829-1

back

Unit: mm

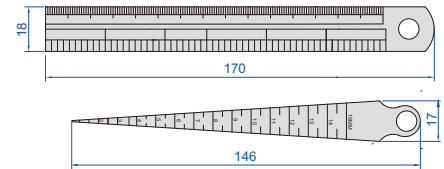

## ALUMINUM RULES



7123-300

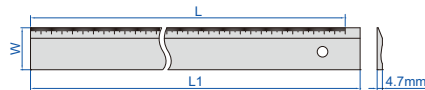

- Made of aluminum, oxidized surface

Code	Range (L)	Accuracy	Graduation	L1	W
7123-300	300mm	±0.5mm	1mm	321mm	50mm
7123-600	600mm	±0.9mm	1mm	624mm	50mm
7123-1000	1000mm	±0.9mm	1mm	1024mm	50mm

## COMBINATION SQUARE (ECONOMIC TYPE)



2276-300

Unit: mm

- Square head (made of zinc): to set the blade at 90° or 45° to an edge of a workpiece accuracy: ±0.5°
- Blade (made of stainless steel): range: 300mm/12", graduation: 1mm and 1/32" on front face, 1mm and 1/16" on back face

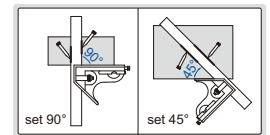
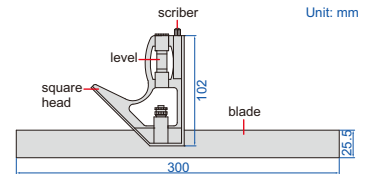

Code  
2276-300

## COMBINATION SQUARE SETS (CLOSE TYPE PROTRACTOR)

- Center head (made of cast iron): to locate center of cylinder with diameter (Ød): 30-100mm accuracy: ±0.15mm
- Protractor head (made of cast iron): to set the blade at desired angle to an edge of a workpiece, and can be used to measure angles range: 0-180°, accuracy: ±20min.
- Square head (made of cast iron): to set the blade at 90° or 45° to an edge of a workpiece accuracy: ±8min for 90° square, ±10min for 45° square
- Blade (made of stainless steel): range: 300mm/12", graduation: 0.5mm and 1/32" on front face, 1mm and 1/64" on back face
- Optional accessory: rigid rule (code 7113)



2278-2



2278-180

Code	Remark
2278-2	2-piece set
2278-180	4-piece set

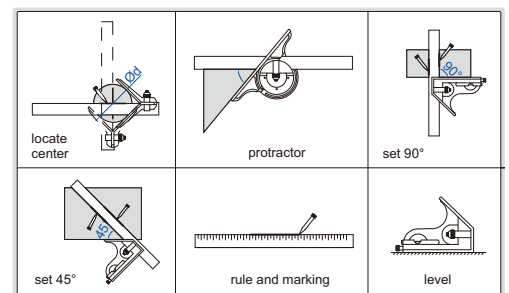
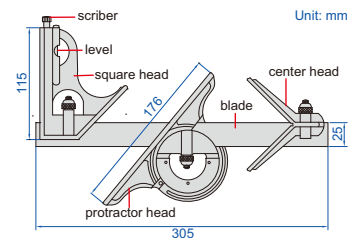

### T-BEVEL

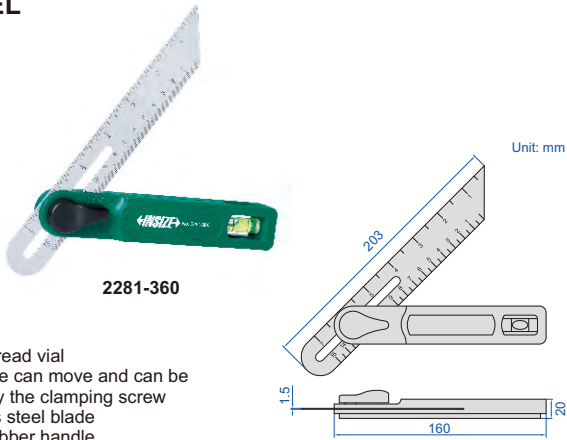

2281-360

- Easy-to-read vial
- The blade can move and can be locked by the clamping screw
- Stainless steel blade
- Tough rubber handle
- Centimeter/inch graduations

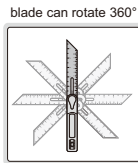
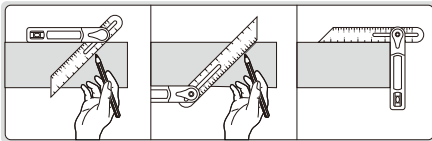

blade can rotate 360°

Code	Angle mark	Accuracy of angle
2281-360	15°, 30°, 45°, 60°, 90°	±1°

### PLASTIC ANGLE SQUARE



2282-180

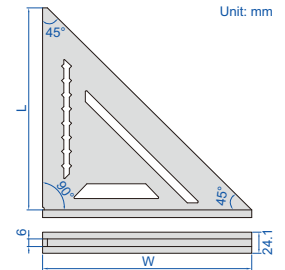

Unit: mm

- Length range: 0-7", graduation: 1/8"
- Angel range: 0-90°, graduation: 1°

Code	Size (L×W)	Accuracy of angle
2282-180	180×185mm	±0.3°

### MARKING GAGES



7120-200A

- Made of carbon steel
- Satin chrome plated

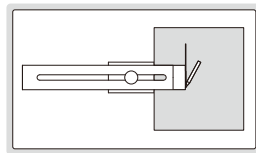
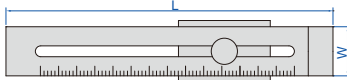

Code	Range	Graduation	Accuracy	L	W
7120-200A	0-200mm	0.1mm	±0.1mm	250mm	40mm
7120-250A	0-250mm	0.1mm	±0.1mm	300mm	40mm
7120-300A	0-300mm	0.1mm	±0.1mm	350mm	40mm

### T-SHAPE MARKING GAGE



1275-150B

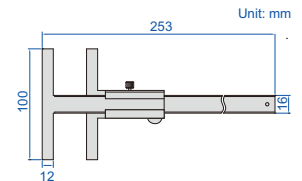
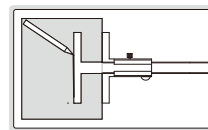

Unit: mm

- Made of stainless steel
- Satin chrome plated reading surface

Code	Range	Graduation	Accuracy
1275-150B	0-150mm	0.02mm	±0.04mm

### CENTER MARKING GAGES

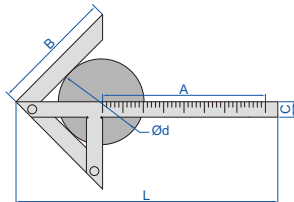

7205-100

- Accuracy: ±0.15mm
- Marking the center of round plates and shafts
- Made of stainless steel
- Satin chrome plated

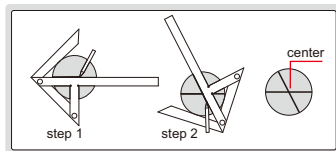

Code	Size (AxB)	Diameter of shafts (Ød)	C	L
7205-100	100x70mm	4-90mm	12mm	153mm
7205-150	150x130mm	4-190mm	15mm	245mm
7205-200	200x150mm	6-220mm	15mm	310mm

### SCRIBER CALIPER



7202-200A

the position of scriber tip can be adjusted



rolling sleeve

- Accuracy: ±0.1mm
- Graduation: 0.1mm, 1/128"
- Made of stainless steel
- Satin chrome plated reading surface
- Carbide scriber tip
- Optional accessory: carbide scriber tip (code SP-SCRIBER-7202)

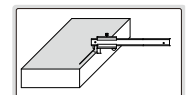

Code	Range
7202-200A	0-200mm/0-8"

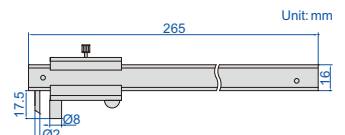

Unit: mm

### SCRIBING CALIPER



7203-300A

- Accuracy:  $\pm 0.1$ mm
- Graduation: 0.1mm
- Made of stainless steel
- Satin chrome plated reading surface
- Hardened scriber tips

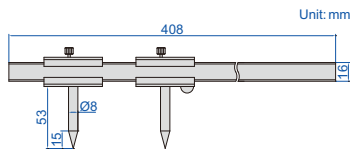
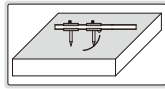

Code	Range
7203-300A	51-300mm

### DIGITAL SCRIBING CALIPER

DATA OUTPUT



1166-150A

- Non waterproof
- Resolution: 0.01mm/0.0005"
- The carbide-tipped jaws facilitate scribing on workpieces
- Buttons: on/off, zero, mm/inch
- Automatic power off, move the digital unit to turn on power
- Battery CR2032, data output
- Made of stainless steel
- Optional accessory: data output cable (code 7315-21 need receiver, 7302-21)

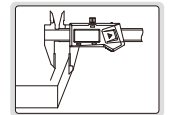
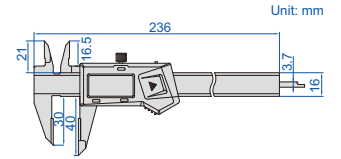

Code	Range	Accuracy
1166-150A	0-150mm/0-6"	$\pm 0.03$ mm

### HEIGHT SCRIBER

- Grooved bottom for cylinder
- Two pins to be set against the edge of surface plate

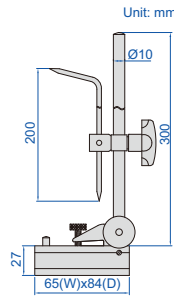

6990-300A

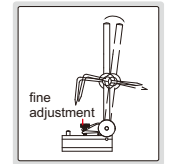
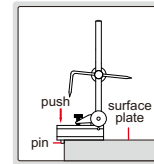

Code
6990-300A

### SCRIBERS



- 7230 and 7231 are nickel plated, 7232 is zinc-plated

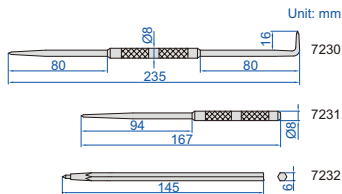

Code	Tip
7230	hardened tips
7231	hardened tip
7232	carbide tip

### PRECISION SCREWDRIVER SET CODE ISGF-0901



ISGF-0901



- Includes:
  - 4 pcs "-": 1.4mm, 2.0mm, 2.4mm, 3.0mm
  - 2 pcs "+": 0#, 1#
- Rotating cap
- Material: CRV, hardness: HRC52~56

### 2-PIECE MEASURING TOOL SET

- Includes:
  - Digital caliper, range 0-150mm/0-6", resolution 0.01mm/0.0005" (code 1108-150)
  - Digital outside micrometer, range 0-25mm/0-1", resolution 0.001mm/0.00005" (code 3109-25A)



Code
5022

5022

### 2-PIECE MEASURING TOOL SET

- Includes:
  - Dial test indicator, range 0.8mm, graduation 0.01mm (code 2380-08)
  - Magnetic stand



Code
5023

5023



## 2-PIECE MEASURING TOOL SET

- Includes:
  - 1) Dial indicator, range 10mm, graduation 0.01mm (code **2308-10A**)
  - 2) Magnetic stand (code **6201-60**)



5024

Code  
5024

## 4-PIECE MEASURING TOOL SETS

- Includes:
  - 1) Vernier caliper, range 0-150mm/0-6" graduation 0.05mm/1/128" (code **1205-150S**) for **5041**, graduation 0.02mm/0.001" (code **1205-1502S**) for **5041-2**
  - 2) Outside micrometer, range 0-25mm, graduation 0.01mm (code **3202-25A**)
  - 3) 90° beveled edge square, 100x70mm, grade 0 (code **4790-1000**)
  - 4) Steel rule, 150mm/6" (code **7110-150**)



5041

Code	Remark
<b>5041</b>	vernier caliper, graduation 0.05mm/1/128" (code <b>1205-150S</b> )
<b>5041-2</b>	vernier caliper, graduation 0.02mm/0.001" (code <b>1205-1502S</b> )

## 4-PIECE MEASURING TOOL SET

- Includes:
  - 1) Digital caliper, range 0-150mm/0-6", resolution 0.01mm/0.0005" (code **1108-150**)
  - 2) Outside micrometer, range 0-25mm, graduation 0.01mm (code **3202-25A**)
  - 3) 90° beveled edge square, 100x70mm, grade 0 (code **4790-1000**)
  - 4) Steel rule, 150mm/6" (code **7110-150**)



5042

Code  
5042

## 6-PIECE MEASURING TOOL SETS

- Includes:
  - 1) Vernier caliper, range 0-150mm/0-6" graduation 0.05mm/1/128" (code **1205-150S**) for **5063**, graduation 0.02mm/0.001" (code **1205-1502S**) for **5063-2**
  - 2) Outside micrometer, range 0-25mm graduation 0.01mm (code **3202-25A**)
  - 3) 90° beveled edge square, 100x70mm grade 00 (code **4790-0100**)
  - 4) Straight edge, 100mm (code **4700-100**)
  - 5) Spring divider, 150mm (code **7260-150**)
  - 6) Steel rule, 200mm/8" (code **7110-200**)



5063

Code	Remark
<b>5063</b>	vernier caliper, graduation 0.05mm/1/128" (code <b>1205-150S</b> )
<b>5063-2</b>	vernier caliper, graduation 0.02mm/0.001" (code <b>1205-1502S</b> )

## 5-PIECE MEASURING TOOL SET

- Includes:
  - 1) Digital caliper, range 0-150mm/0-6", resolution 0.01mm/0.0005" (code **1108-150**)
  - 2) Digital outside micrometer, range 0-25mm/0-1", resolution 0.001mm/0.00005" (code **3109-25A**)
  - 3) Digital indicator, range 12.7mm/0.5", resolution 0.01mm/0.0005" (code **2112-10**)
  - 4) Magnetic stand (code **6201-60**)
  - 5) Micrometer stand (code **6300**)



5052

Code  
5052

## 9-PIECE MEASURING TOOL SET

- Includes:
  - 1) Digital caliper, range 0-150mm/0-6", resolution 0.01mm/0.0005" (code **1108-150**)
  - 2) Outside micrometer, range 0-25mm, graduation 0.01mm (code **3202-25A**)
  - 3) Protractor, range 0-180°, graduation 1° (code **4799-180**)
  - 4) Pitch gauge, range 0.25-7mm, 24 pcs, metric 60° thread (code **4820-124**)
  - 5) Radius gauge, range 1-7mm (code **4801-17**)
  - 6) Feeler gauge, range 0.05-1.00mm, 20 pcs (code **4602-20**)
  - 7) 90° beveled edge square, 100x70mm, grade 0 (code **4790-1000**)
  - 8) Scriber (code **7230**)
  - 9) Steel rule, 150mm/6" (code **7110-150**)



5091

Code  
5091

## 13-PIECE MEASURING TOOL SET

- Includes:
  - 1) Digital caliper, range 0-150mm/0-6", resolution 0.01mm/0.0005" (code **1108-150**)
  - 2) Outside micrometer, range 0-25mm, graduation 0.01mm (code **3202-25A**)
  - 3) Dial indicator, range 10mm, graduation 0.01mm (code **2308-10A**)
  - 4) Magnetic stand (code **6201-60**)
  - 5) Protractor, range 0-180°, graduation 1° (code **4799-180**)
  - 6) Pitch gauge, range 0.25-7mm, 24 pcs, metric 60° thread (code **4820-124**)
  - 7) Radius gauge, range 1-7mm (code **4801-17**)
  - 8) Feeler gauge, range 0.05-1.00mm, 20 pcs (code **4602-20**)
  - 9) 90° beveled edge square, 100x70mm, grade 0 (code **4790-1000**)
  - 10) Scriber (code **7230**)
  - 11) Steel rule, 150mm/6" (code **7110-150**)
  - 12) Depth base attachment (code **6140**)
  - 13) Zero setting bar for depth base attachment



5013

Code  
5013

## GRANITE SURFACE PLATES

CUSTOM-MADE  
SUPPLY SPECIAL SIZES ACCORDING  
TO CUSTOMER'S REQUEST

- Made of Indian granite, high hardness, free from deterioration or dimensional change over time, minimal changes in dimension due to temperature changes
- Meet DIN876, grade 00 is for inspection room or lab, grade 0 is for workshop
- Optional accessory:  
stand for granite surface plate (code **6902**),  
jack for granite surface plate (code **6903**)



6900-132



### Grade 00

Code	Size (LxWxH)	Flatness	Weight (kg)	Max. load (kg)
6900-132 *	300x200x60mm	2.7µm	11	30
6900-142 *	400x250x60mm	2.9µm	18	50
6900-144 *	400x400x60mm	3.1µm	29	60
6900-153 *	500x315x70mm	3.2µm	33	60
6900-164 *	630x400x80mm	3.5µm	60	65
6900-166 *	630x630x100mm	3.8µm	119	75
6900-185 *	800x500x100mm	3.9µm	120	100
6900-1106 *	1000x630x140mm	4.4µm	265	200
6900-1107 *	1000x750x150mm	4.5µm	337	300
6900-1101 *	1000x1000x150mm	4.8µm	450	400
6900-1128 *	1200x800x160mm	4.9µm	461	500
6900-1161 *	1600x1000x180mm	5.8µm	864	600

### Grade 0

Code	Size (LxWxH)	Flatness	Weight (kg)	Max. load (kg)
6900-032 *	300x200x60mm	5.4µm	11	60
6900-042 *	400x250x60mm	5.9µm	18	100
6900-044 *	400x400x60mm	6.3µm	29	120
6900-053 *	500x315x70mm	6.4µm	33	120
6900-064 *	630x400x80mm	7.0µm	60	130
6900-066 *	630x630x100mm	7.6µm	119	150
6900-085 *	800x500x100mm	7.8µm	120	200
6900-0106 *	1000x630x140mm	8.7µm	265	400
6900-0107 *	1000x750x150mm	9.0µm	337	600
6900-0101 *	1000x1000x150mm	9.7µm	450	800
6900-0128 *	1200x800x160mm	9.8µm	461	1000
6900-0161 *	1600x1000x180mm	11.5µm	864	1200

\*Supplied with manufacturer inspection certificate

## STANDS FOR GRANITE SURFACE PLATES

- For medium size granite surface plates
- 5 jacks are included
- Adjusting range of jacks: 25mm
- One foot on the bottom is adjustable



6902-64A

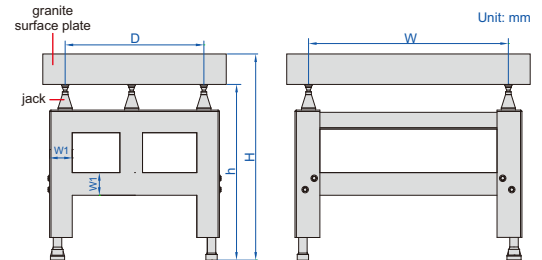

### Low stands

Code	For granite surface plate	W	D	H (with granite surface plate)	h (without granite surface plate)	W1
6902-64A	630x400x80mm (code <b>6900-064</b> and <b>6900-164</b> )	352	224	775-800	695-720	80
6902-66A	630x630x100mm (code <b>6900-066</b> and <b>6900-166</b> )	352	352	775-800	675-700	80
6902-85A	800x500x100mm (code <b>6900-085</b> and <b>6900-185</b> )	448	280	775-800	675-700	80
6902-106A	1000x630x140mm (code <b>6900-0106</b> and <b>6900-1106</b> )	560	352	755-780	615-640	80
6902-107A	1000x750x150mm (code <b>6900-0107</b> and <b>6900-1107</b> )	560	420	755-780	605-630	80
6902-101A	1000x1000x150mm (code <b>6900-0101</b> and <b>6900-1101</b> )	560	560	755-780	605-630	80
6902-128A	1200x800x160mm (code <b>6900-0128</b> and <b>6900-1128</b> )	672	448	755-780	595-620	80
6902-161A	1600x1000x180mm (code <b>6900-0161</b> and <b>6900-1161</b> )	896	560	755-780	575-600	100

### High stands

Code	For granite surface plate	W	D	H (with granite surface plate)	h (without granite surface plate)	W1
6902-64H	630x400x80mm (code <b>6900-064</b> and <b>6900-164</b> )	352	224	1000-1025	920-945	80
6902-66H	630x630x100mm (code <b>6900-066</b> and <b>6900-166</b> )	352	352	1000-1025	900-925	80
6902-85H	800x500x100mm (code <b>6900-085</b> and <b>6900-185</b> )	448	280	1000-1025	900-925	80
6902-106H	1000x630x140mm (code <b>6900-0106</b> and <b>6900-1106</b> )	560	352	1000-1025	860-885	80
6902-107H	1000x750x150mm (code <b>6900-0107</b> and <b>6900-1107</b> )	560	420	1000-1025	850-875	80
6902-101H	1000x1000x150mm (code <b>6900-0101</b> and <b>6900-1101</b> )	560	560	1000-1025	850-875	80
6902-128H	1200x800x160mm (code <b>6900-0128</b> and <b>6900-1128</b> )	672	448	1000-1025	840-865	80
6902-161H	1600x1000x180mm (code <b>6900-0161</b> and <b>6900-1161</b> )	896	560	1000-1025	820-845	100

## V-BLOCK SETS



6896-11

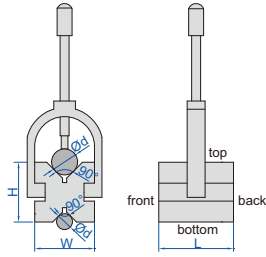

- Hold cylindrical workpieces for inspection and machining
- Two V-blocks per set
- Made of alloy steel
- Hardened to HRC60±2
- V groove on the top for large shafts
- V groove on the bottom for small shafts (except 6896-10)

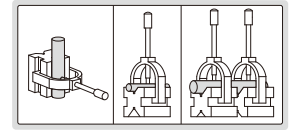

Code	Size (LxWxH)	Range of shafts (Ød)	Parallelism of both V grooves to top and bottom sides	Squareness of both V grooves to front and back sides	Height difference of a matched pair
6896-10	25x20x20mm	3-20mm	3µm	3µm	3µm
6896-11	50x40x40mm	5-30mm	5µm	5µm	5µm
6896-12	80x63x63mm	7-63mm	5µm	5µm	5µm
6896-13	100x80x80mm	7-80mm	5µm	5µm	5µm
6896-14	70x140x140mm	9-140mm	5µm	5µm	5µm

## V-BLOCK SETS

- For positioning cylindrical workpieces
- Two V-blocks per set
- Each V-block has four 90° V-grooves
- Cast iron, hardness HB170-240



6805-2

Code	Size (LxHxW)	Range of shafts (Ød)	Parallelism of four V grooves to all sides	Height difference of a matched pair
6805-1	150x130x75mm	8-120mm	15µm	20µm
6805-2	200x170x90mm	12-180mm	15µm	20µm

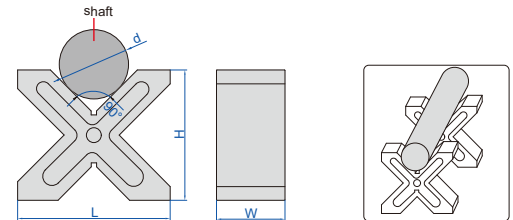

## V-BLOCK SETS



6887-3

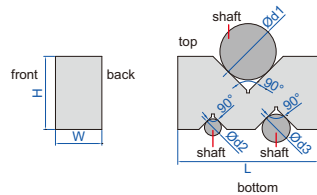
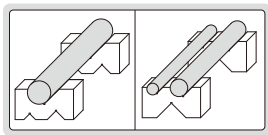

- Two V-blocks per set
- Made of hardened tool steel

Code	Parallelism of three V grooves to top and bottom sides	Height difference of a matched pair
6887-1	5µm	5µm
6887-2	5µm	5µm
6887-3	5µm	5µm
6887-4	5µm	5µm

Code	Size (LxWxH)	Range of shafts (Ød1)	Range of shafts (Ød2)	Range of shafts (Ød3)
6887-1	50x19x24mm	3-32mm	3-16mm	3-22mm
6887-2	75x24x35mm	3-50mm	3-20mm	3-32mm
6887-3	100x33x52mm	3-68mm	3-26mm	3-40mm
6887-4	125x44x69mm	3-87mm	3-34mm	3-50mm

## ROLLER BEARING V-BLOCK SETS



6888-1

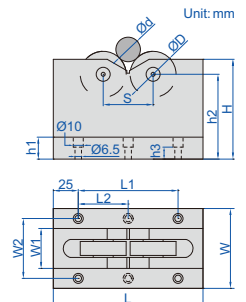

- Runout accuracy: 5µm
- Parallelism of bearings to bottom: 12µm
- Two V-blocks per set
- Workpieces don't get damaged due to bearings
- Suitable for heavy workpieces

Code	W1	W2	h1	h2	h3	L1	L2	S
6888-1	22	44	20	85	12	100	-	60
6888-2	40	60	22	85	12	100	-	50
6888-3	60	80	30	124	20	180	90	120

Code	Size (LxWxH)	Code of bearings	Diameter of bearings (ØD)	Range of shafts (Ød)	Load capacity
6888-1	150x60x100mm	16004 ZZ	42mm	25-70mm	500kg
6888-2	150x80x100mm	6303 ZZ	47mm	5-55mm	1000kg
6888-3	230x100x150mm	6306 ZZ	72mm	70-200mm	1000kg

### GRANITE V-BLOCK SET

- Two V-blocks per set



6897-1

Code	Size (LxWxH)	Range of shafts (Ød)	Parallelism of V groove to bottom	Height difference of a matchet pair
6897-1	70x50x70mm	6-75mm	4µm	5µm

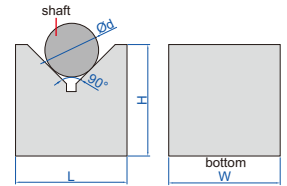
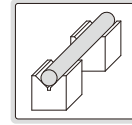

### MAGNETIC V-BLOCKS (PROFESSIONAL TYPE)

HARDENED SURFACES

HIGH PRECISION

STRONG MAGNETIC FORCE



6889-11

6889-1

- Hardened, high accuracy, strong magnetic force, for grinding, light milling, drilling and inspection of round and square workpieces
- All working surfaces are hardened to HRC60±2
- Magnetic force on top, bottom and two V grooves
- V groove on the top for large shafts
- V groove on the bottom for small shafts
- Suitable for cast iron surface plates and granite surface plates

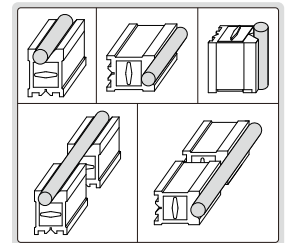

#### Individual

Code	Size (LxWxH)	Range of shafts (Ød)	Magnetic force	Parallelism of V grooves to top, bottom, left, right sides	Squareness of V grooves to back side
6889-11	75x56x75mm	5-40mm	85kgf	5µm	5µm
6889-22	100x70x95mm	5-65mm	150kgf	5µm	5µm
6889-33	150x75x100mm	5-70mm	190kgf	6µm	6µm
6889-55	160x125x130mm	5-140mm	220kgf	12µm	12µm
6889-44	200x125x150mm	10-140mm	400kgf	12µm	12µm

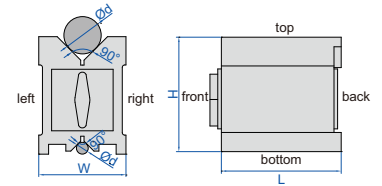

#### Matched pair

Code	Size (LxWxH)	Range of shafts (Ød)	Magnetic force	Parallelism of V grooves to top, bottom, left, right sides	Squareness of V grooves to back side	Height difference of a matched pair
6889-1	75x56x75mm	5-40mm	85kgf	5µm	5µm	5µm
6889-2	100x70x95mm	5-65mm	150kgf	5µm	5µm	5µm
6889-3	150x75x100mm	5-70mm	190kgf	6µm	6µm	6µm
6889-5	160x125x130mm	5-140mm	220kgf	12µm	12µm	12µm
6889-4	200x125x150mm	10-140mm	400kgf	12µm	12µm	12µm

### MAGNETIC V-BLOCKS (ECONOMIC TYPE)

ATTENTION: NOT SUITABLE FOR STEEL OR IRON SURFACES, OTHERWISE THE MAGNETIC FORCE WILL BE REDUCED

- Hold cylindrical workpieces for inspection and machining
- Not hardened
- V groove on the top for large shafts
- V groove on the bottom for small shafts
- Not suitable for steel or iron surface, otherwise the magnetic force will be reduced



6801-1201

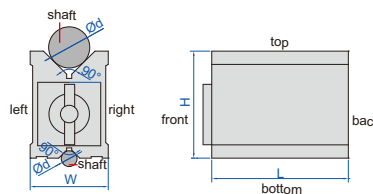

ATTENTION: NOT HARDENED

Code	Size (LxWxH)	Range of shafts (Ød)	Magnetic force	Parallelism of V grooves to top, bottom, left, right side	Squareness of V grooves to back side
6801-1201	80x70x95mm	6-67mm	64kgf	10µm	10µm
6801-1202	100x70x95mm	6-67mm	80kgf	10µm	10µm
6801-1203	120x70x95mm	6-67mm	96kgf	10µm	10µm

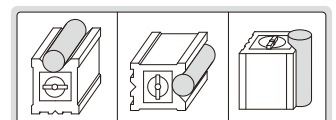

## MAGNETIC V-BLOCK (ECONOMIC TYPE)

**ATTENTION:**  
NOT HARDENED

**ATTENTION:** NOT SUITABLE FOR STEEL OR IRON SURFACES,  
OTHERWISE THE MAGNETIC FORCE WILL BE REDUCED

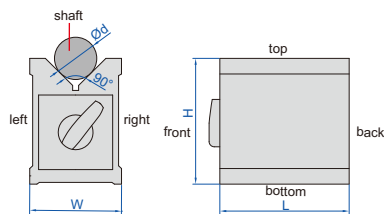

6890-702

- Parallelism of V groove to top, bottom, left and right sides: 10µm
- Hold cylindrical workpieces for inspection and machining
- Supplied in single piece
- Not hardened
- Not suitable for steel or iron surfaces, otherwise the magnetic force will be reduced

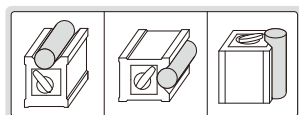

Code	Size (LxWxH)	Range of shafts (Ød)	Magnetic force	Squareness of V groove to back side
6890-702	70x60x73mm	6-44mm	56kgf	10µm

## MAGNETIC INDUCTION V-BLOCK SET

**ATTENTION:** NOT HARDENED, DO NOT  
ROTATE WORKPIECES ON V-BLOCKS



6878-1

- Parallelism of both V grooves to top and bottom sides: 10µm
- Height difference of a matched pair: 10µm
- Hold cylindrical workpieces for inspection and machining
- To be used on magnetic chucks
- Two V-blocks per set
- V groove on the top for large shafts
- V groove on the bottom for small shafts
- Hardness HRB70
- Copper magnetic strips

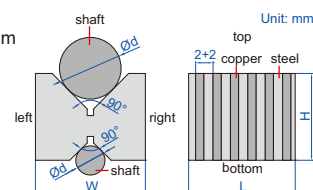

Code	Size (LxWxH)	Range of shafts (Ød)	Pole pitch
6878-1	49x58x46mm	5-56mm	2+2mm

## MAGNETIC V-BLOCK SETS

**ATTENTION:** NOT HARDENED, DO NOT  
ROTATE WORKPIECES ON V-BLOCKS

**ATTENTION:** LOW  
MAGNETIC FORCE

- Hold cylindrical workpieces for inspection, not suitable for machining due to low magnetic force
- Two V-blocks per set
- Hardness HRB70

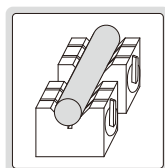

6891-1

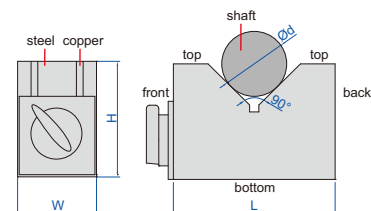

Code	Size (LxWxH)	Range of shafts (Ød)	Magnetic force	Parallelism of V groove to bottom and back sides	Height difference of a matched pair
6891-1	70x40x50mm	6-46mm	15kgf	10µm	10µm
6891-3	150x50x100mm	6-125mm	21kgf	10µm	10µm

## MAGNETIC SQUARE WITH V GROOVE

**ATTENTION:** NOT HARDENED, DO NOT  
ROTATE WORKPIECES ON V-BLOCKS

- Hold flat and cylindrical workpieces for inspection and machining
- Magnetic force on top, left, right and V grooves
- Parallelism and squareness of top, bottom, left, right and back: 20µm
- Parallelism and squareness of V grooves to top, bottom, left, right and back: 20µm



6539-100

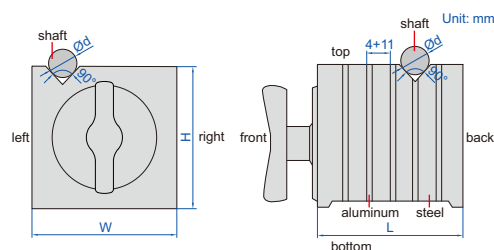

Code	Size (LxWxH)	Magnetic force of V grooves		Magnetic force of top, left and right sides		Range of shafts (Ød)
		on granite surface plate	on cast iron plate	on granite surface plate	on cast iron plate	
6539-100	100x100x100mm	30kgf	25kgf	50kgf	30kgf	5-30mm

### GRANITE SQUARE WITH V GROOVE



4142-200

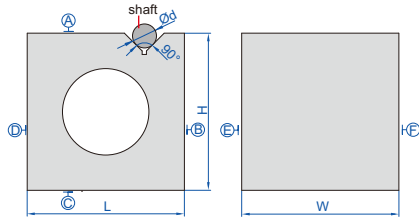

- Parallelism and squareness of A, B, C, D, E and F: 6µm
- Parallelism and squareness of V groove to A, B, C, D, E and F: 6µm

Code	Size (LxWxH)	Range of shaft (Ød)
4142-200	200x200x200mm	9-70mm

### PERMANENT MAGNETIC CHUCK

ATTENTION:  
NOT HARDENED

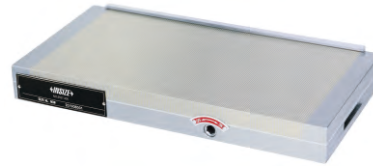

6537-400

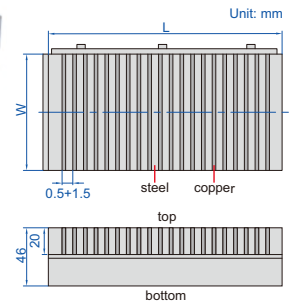

- Parallelism of top to bottom: 0.02mm/300mm

Code	Table size (LxW)	Magnetic force	Pole pitch
6537-400	400x200mm	8kgf/cm <sup>2</sup>	0.5+1.5mm

### PARALLEL SETS

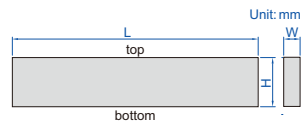

6533-144

Code	Parallels per set	Length (L)	Thickness (W)	Height (H)
6533-6	6 pairs	200mm	9.5mm	35, 40, 45, 50, 55, 58mm
6533-8	8 pairs	160mm	8mm	12*, 17, 22, 25, 28, 32, 36, 38mm
6533-81	8 pairs	200mm	8mm	17, 22, 26, 28, 32, 36, 38, 42mm
6533-9	9 pairs	160mm	4mm	10*, 14*, 18, 22, 26, 30, 34, 38, 42mm
6533-10	10 pairs	150mm	3mm	13, 16, 19, 22, 25, 28, 31, 35, 38, 41mm
6533-144	14 pairs	150mm	10mm	14, 16, 18, 20, 22, 24, 26, 28, 30, 32, 35, 40, 45, 50mm

- Parallelism between top and bottom: 5µm
- Height difference of a matched pair: 5µm
- Hardened to HRC55-60
- Made of alloy tool steel

\*Parallelism between top and bottom and height difference of a matched pair of 12mm in **6533-8**, 10mm, 14mm in **6533-9** is 7µm

### PARALLEL SET

- Height difference of a matched pair: 5µm
- Hardened to HRC55-60
- Made of alloy tool steel

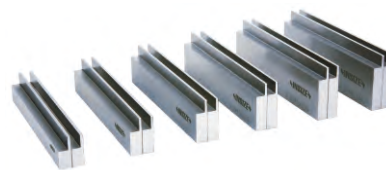
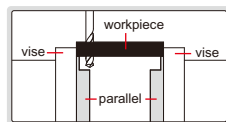

6534-6

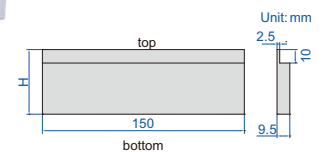

Code	Parallels per set	Parallelism between top and bottom	Height (H)
6534-6	6 pairs	5µm	25, 30, 35, 40, 45, 48mm

### PARALLEL SETS

- Parallelism between top and bottom: 5µm
- Height difference of a matched pair: 5µm
- Made of alloy tool steel
- Hardened to HRC55-60

6511-20

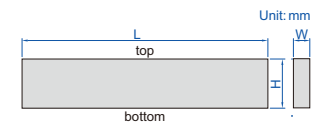
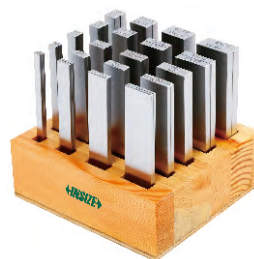

Code	Parallels per set	Length (L)	Height (H)×Thickness (W)
6511-20	20 pairs	100mm	5×2*, 10×2, 15×2, 20×2, 6×3*, 11×3, 16×3, 21×3, 7×4*, 12×4, 17×4, 22×4, 8×5*, 13×5, 18×5, 23×5, 9×6*, 14×6, 19×6, 24×6mm
6511-24	24 pairs	125mm	11×8, 16×8, 21×8, 26×8, 31×8, 36×8, 13×10, 18×10, 23×10, 28×10, 33×10, 38×10, 15×12, 20×12, 25×12, 30×12, 35×12, 40×12, 17×14, 22×14, 27×14, 32×14, 37×14, 42×14mm
6511-241	24 pairs	150mm	11×8, 16×8, 21×8, 26×8, 31×8, 36×8, 13×10, 18×10, 23×10, 28×10, 33×10, 38×10, 15×12, 20×12, 25×12, 30×12, 35×12, 40×12, 17×14, 22×14, 27×14, 32×14, 37×14, 42×14mm

\*Parallelism between top and bottom and height difference of a matched pair of 5×2mm, 6×3mm, 7×4mm, 8×5mm and 9×6mm in **6511-20** is 7µm

## GRANITE PARALLEL SET

- Made of granite, hard and no rusty, no dimensional change over time or temperature change
- Two parallels per set

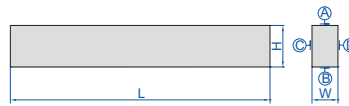
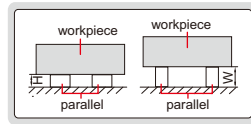

4143-250

Code	Size (LxWxH)	Parallelism between A and B	Parallelism between C and D	Height difference of a matched pair
4143-250	250x25x40mm	3µm	3µm	3µm

## PARALLEL/SQUARE SET

- Pairs of matched blocks for positioning and set-up
- Screws and wrench are included
- Hardness HRC 55-62

screws and wrench are included



6531-25

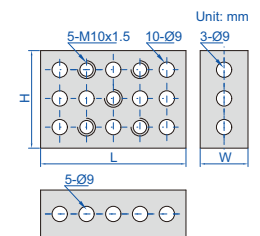

Code	Size (LxHxW)	Size accuracy	Squareness	Parallelism	Height difference of a matched pair
6531-25	75x50x25mm	10µm	7µm/25mm	10µm	10µm

## MAGNETIC INDUCTION PARALLEL SET

ATTENTION:  
NOT HARDENED

- To be used on magnetic chucks
- Two parallels per set
- Hardness HRB70
- Copper magnetic strips

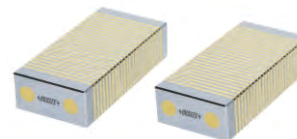
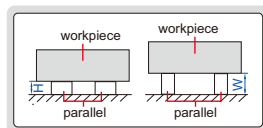

6879-1

Code	Size (LxWxH)	Pole pitch	Parallelism between A and B	Parallelism between C and D	Height difference of a matched pair
6879-1	100x50x25mm	2+2mm	10µm	10µm	10µm

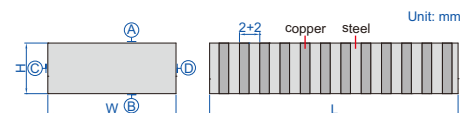

## ANGLE PLATE SETS

- Accuracy: ±20 seconds
- For angle set-up in tooling, production and inspection
- Hardness HRC52

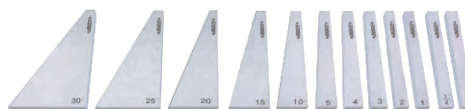

4006-12

Code	Angle plates included	Angle α
4006-10	10 pcs	1°, 2°, 3°, 4°, 5°, 10°, 15°, 20°, 25°, 30°
4006-12	12 pcs	1/4°, 1/2°, 1°, 2°, 3°, 4°, 5°, 10°, 15°, 20°, 25°, 30°

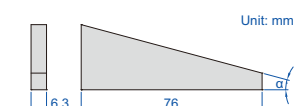

### ADJUSTABLE ANGLE BLOCK



6535-30

- Graduation of angle: 10 minutes
- Made of hardened tool steel
- With locking screw

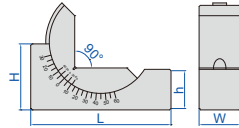

Code	Size (LxWxH)	h	Adjustable angle	Accuracy of angle
6535-30	102x30x49mm	30mm	30°~0°~60°	10 minutes

### RIGHT ANGLE PLATE

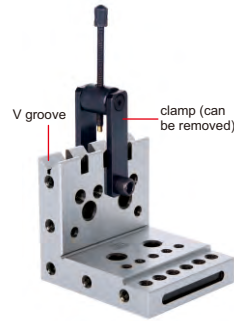

6547-1

- Made of alloy steel
- Hardened to HRC60±2
- V groove for cylinders
- Parallelism and squareness between A, B, C, D, E, F, G and H: 10µm
- Parallelism and squareness of V groove to A, B, C, D, E, F, G and H: 10µm

Code	Size (LxWxH)
6547-1	100x100x115mm

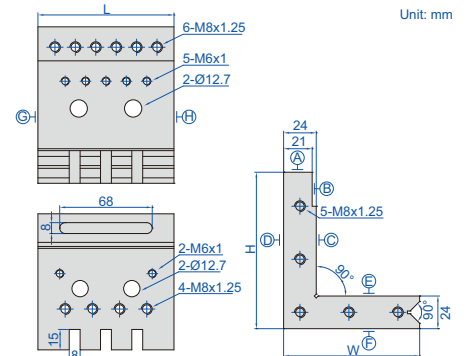

### SINE BARS

CAN BE CUSTOMIZED



4155-100

the front and back ends and two sides have mounting holes to install plate

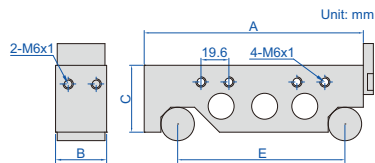
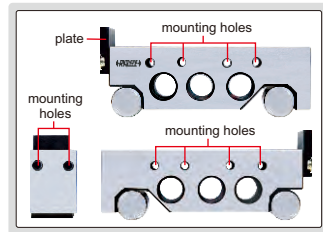
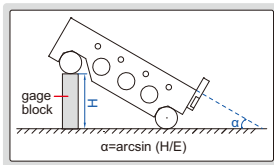

- Made of alloy tool steel

Code	Roller distance (E)	Table size (AxB)	C	Accuracy of $\alpha$ at 30°
4155-100	100mm	130x30mm	40	±5 seconds
4155-200	200mm	230x30mm	40	±5 seconds
4155-300	300mm	345x40mm	50	±8 seconds

### SINE BAR



4158-100

- Made of alloy tool steel

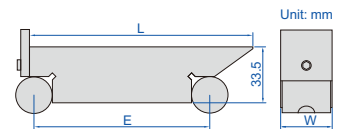
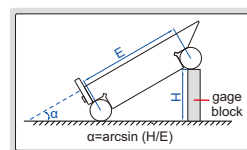

Code	Roller distance (E)	Table size (LxW)	Accuracy of $\alpha$ at 30°
4158-100	100mm	130x30mm	±5 seconds

### SINE TABLE

- Accuracy of angle: ±15 seconds
- Made of alloy tool steel
- Hardness HRC58-60



6527-100

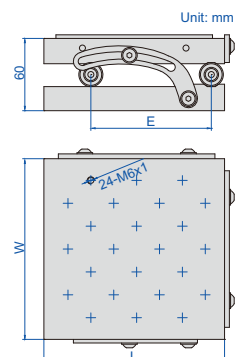

Code	Roller distance (E)	Table size (LxW)	Adjustable angle
6527-100	100mm	150x150mm	0-60°



## MAGNETIC SINE TABLE

**ATTENTION:**  
NOT HARDENED

- Accuracy of angle:  $\pm 15$  seconds
- Adjustable angle: 0-60°

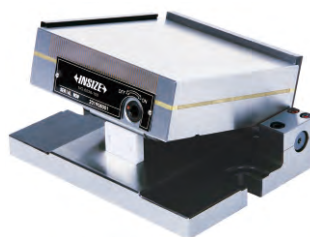

6538-100

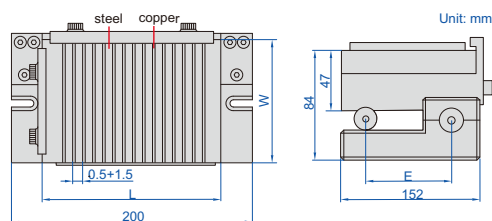

Code	Table size (L×W)	Roller distance (E)
6538-100	150×150mm	100mm

## PRECISION SINE VISES

- Parallelism: 5 $\mu$ m/100mm
- Squareness: 5 $\mu$ m/100mm
- Accuracy of angle:  $\pm 20$  seconds
- Made of alloy steel
- Hardness HRC58-60

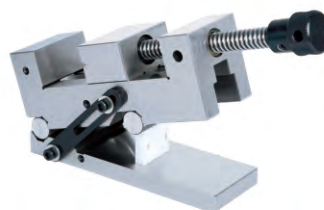

6513-85

Code	Jaw opening (Q)	Jaw width (W)	Roller distance (E)	(mm)		
				L	H	M
6513-65	0-65	50	100	150	85	25
6513-85	0-85	63	100	185	91.5	32
6513-100	0-100	73	150	205	105	35
6513-1001	0-100	80	150	215	108	40
6513-125	0-125	88	150	245	108	40
6513-1251	0-125	100	200	255	116	45
6513-160	0-160	125	200	295	125	50
6513-175	0-175	150	200	315	125	50

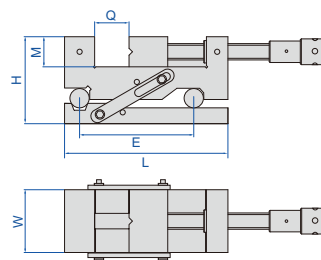

## PRECISION UNIVERSAL VISE

- Horizontal rotary: range 360°, graduation 0.05°
- Vertical incline: range 45°, graduation 0.05°
- With incline adjust knob
- Parallelism and squareness between A, B, C and D: 5 $\mu$ m/100mm, parallelism between D and E at 0°: 10 $\mu$ m/100mm
- Made of tool steel
- Hardness HRC56-58

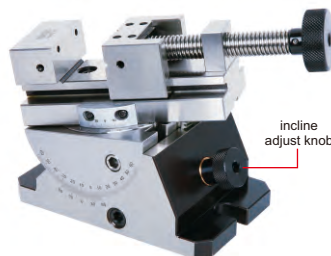

6521-80

Code	Jaw opening (Q)	Jaw width (W)
6521-80	0-80mm	70mm

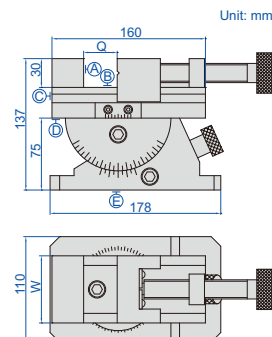

## PRECISION VISES

Code	Jaw opening (Q)	Jaw width (W)	L	H	M
6520-36	0-36mm	38mm	115mm	48mm	25mm
6520-67	0-67mm	50mm	150mm	50mm	25mm
6520-87	0-87mm	63mm	185mm	63mm	32mm
6520-102	0-102mm	73mm	205mm	70mm	35mm
6520-1021	0-102mm	80mm	215mm	80mm	40mm
6520-127	0-127mm	88mm	245mm	80mm	40mm
6520-1271	0-127mm	100mm	255mm	90mm	45mm
6520-162	0-162mm	125mm	295mm	100mm	50mm
6520-175	0-175mm	150mm	315mm	100mm	50mm
6520-200	0-200mm	200mm	350mm	110mm	55mm



6520-73A

- Parallelism: 5 $\mu$ m/100mm
- Squareness: 5 $\mu$ m/100mm
- Made of alloy steel
- Hardness HRC58-60

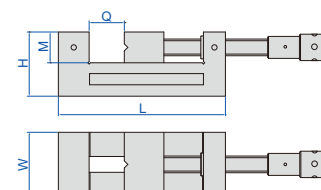

### QUICK MOVING PRECISION VISES

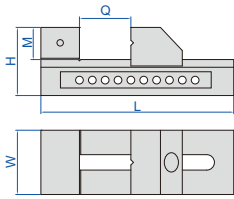

6526-80

- Parallelism: 5µm/100mm
- Squareness: 5µm/100mm
- Made of alloy steel
- Hardness HRC58-60

Code	Jaw opening (Q)	Jaw width (W)	L	H	M
6526-20	0-20mm	25mm	65mm	29mm	9.3mm
6526-40	0-40mm	38mm	100mm	48mm	23mm
6526-65	0-65mm	50mm	135mm	50mm	25mm
6526-85	0-85mm	63mm	170mm	63mm	32mm
6526-100	0-100mm	73mm	185mm	70mm	35mm
6526-1001	0-100mm	80mm	195mm	80mm	40mm
6526-125	0-125mm	88mm	230mm	80mm	40mm
6526-1251	0-125mm	100mm	240mm	90mm	45mm
6526-160	0-160mm	125mm	280mm	100mm	50mm
6526-175	0-175mm	150mm	300mm	100mm	50mm
6526-208	0-208mm	200mm	350mm	110mm	55mm

### X-AXIS STAGE

- Cross roller guides, achieve high precision and smooth movement
- Stages made of aluminum alloy



6582-602

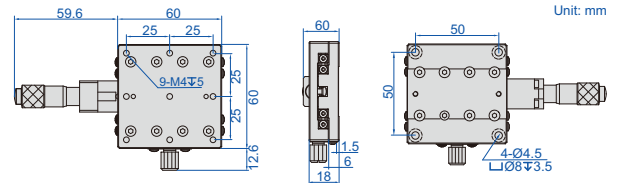

#### SPECIFICATION (micrometer in the middle)

Code	X-axis displacement	Parallelism of top to bottom surface	Micrometer graduation	Micrometer accuracy	Maximum load	Micrometer location	Stage size	Weight
6582-602	±6.5mm	0.03mm	0.01mm	0.01mm	49N (5kgf)	middle	60x60mm	0.24kg

### XY-AXIS STAGE

- Cross roller guides, achieve high precision and smooth movement
- Stages made of aluminum alloy



6584-602

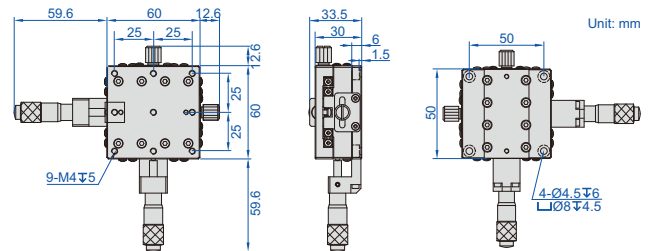

#### SPECIFICATION (micrometer in the middle)

Code	XY-axis displacement	Parallelism of top to bottom surface	Micrometer graduation	Micrometer accuracy	Maximum load	Micrometer location	Stage size	Weight
6584-602	±6.5mm	0.06mm	0.01mm	0.01mm	49N (5kgf)	middle	60x60mm	0.48kg

### CENTERING INDICATOR

POPULAR MODEL



2385-3

- Provides quick and accurate centering in boring and milling set-up
- Maximum speed is recommended not to exceed 800RPM

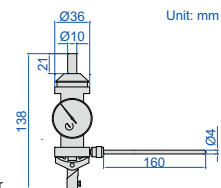
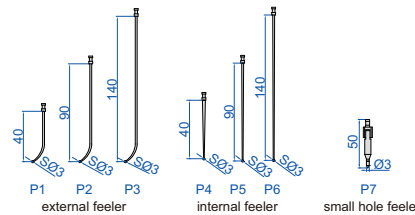
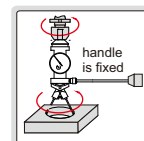
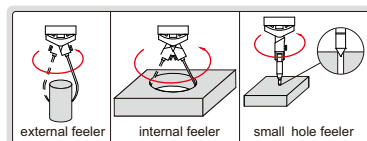

VIDEO

Feeler	Measuring diameter	Accuracy
P1	Ø0-60mm	0.015mm
P2	Ø0-160mm	0.02mm
P3	Ø0-250mm	0.03mm
P4	Ø3.2-80mm	0.015mm
P5	Ø3.2-180mm	0.02mm
P6	Ø3.2-280mm	0.03mm
P7	Ø0-2.8mm	0.015mm

Code  
2385-3

## LARGE SHANK ELECTRONIC EDGE FINDERS



6572-1

6572-2

- The shank is electrically conducted to the metal workpiece through the chuck and table. The LED lights up and the beeper sounds (only for **6572-2**), when the ball touches the workpiece
- Not suitable for rotary use
- Hardened shank and contact ball

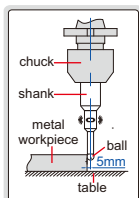

Code	Shank (A)	Contact ball (B)	Accuracy	Beeper	Battery
6572-1	Ø32mm	SØ10mm	5µm	without	23A, 12V×1 pc
6572-2	Ø32mm	SØ10mm	5µm	with	23A, 12V×1 pc

## ELECTRONIC EDGE FINDERS

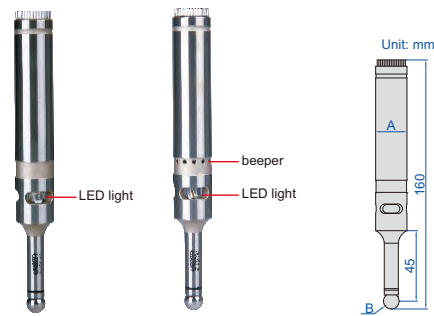

6566-2

6566-3

- The shank is electrically conducted to the metal workpiece through the chuck and table. The LED lights up and the beeper sounds (only for **6566-3**), when the ball touches the workpiece
- Not suitable for rotary use
- Hardened shank and contact ball

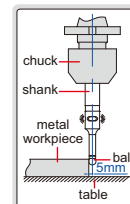

Code	Shank (A)	Contact ball (B)	Accuracy	Beeper	Battery
6566-2	Ø20mm	SØ10mm	5µm	without	23A, 12V×1 pc
6566-3	Ø20mm	SØ10mm	5µm	with	23A, 12V×1 pc

## NON-MAGNETIC EDGE FINDERS

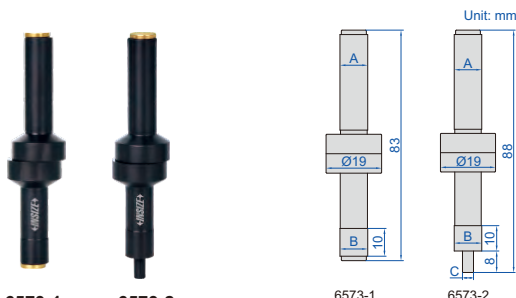

6573-1

6573-2

6573-1

6573-2

- TiAlN coating, non-magnetic, hardness HV2500, extremely wear resistance
- Suitable for machine speed 400~600rpm

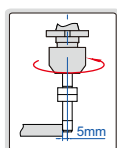

6573-1

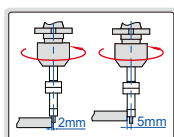

6573-2

Code	Shank (A)	Contact point (B)	Contact point (C)	Accuracy
6573-1	Ø10mm	Ø10mm	—	5µm
6573-2	Ø10mm	Ø10mm	Ø4mm	5µm

## EDGE FINDERS

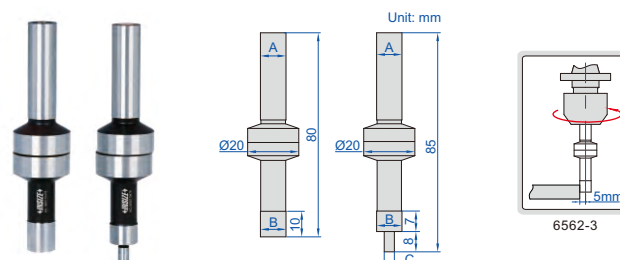

6562-3

6562-4

6562-3

6562-4

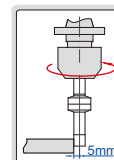

6562-3

- Hardened shank and contact point
- Suitable for machine speed 400-600rpm

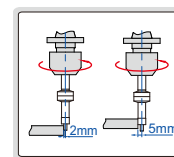

6562-4

Code	Shank(A)	Contact point (B)	Contact point (C)	Accuracy
6562-3	Ø10mm	Ø10mm	—	5µm
6562-4	Ø10mm	Ø10mm	Ø4mm	5µm

## EDGE FINDER

- Hardened shank and contact point
- Suitable for machine speed 400-600rpm

Code	Shank (A)	Contact point (B)	Accuracy
6567-1	Ø10mm	Ø6mm	8µm

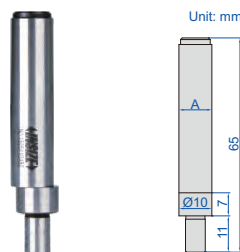

6567-1

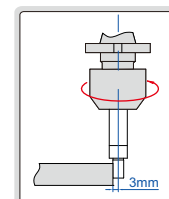

## CERAMIC EDGE FINDER

- Ceramic contact point, non magnetic
- Suitable for machine speed 400-600rpm

Code	Shank (A)	Contact point (B)	Accuracy
6568-1	Ø10mm	Ø10mm	8µm



6568-1

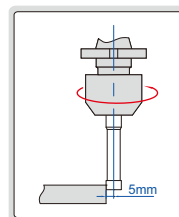
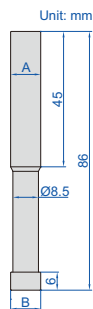

## TRIGGER-TYPE 3D PROBE (AUDIBLE AND VISUAL ALARM) CODE 9410

IP67  
WATERPROOF

- Suitable for all kinds of machining centers, CNC boring machines, milling machines, drilling and tapping centers
- Suitable for workpiece detection of various solid materials
- Manually set the workpiece coordinates and machining reference points before CNC machining process
- In the process of CNC machining, manually detect and control key dimensions and position coordinates and their accuracy
- Detect the accuracy of the key size, shape and position of the workpiece after completion of CNC machining
- Standard Ø20mm shank diameter, held by CNC
- LED indicator and buzzer indicate the trigger state of the probe
- Using lithium battery charging technology, no need to replace the battery
- The battery (5% utilization rate per shift) can be used continuously for 90 days
- Type-C interface
- Optional accessory: styli and extension bar

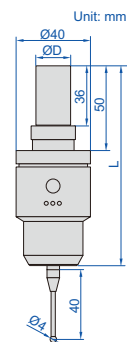

### SPECIFICATION

Probe length (L)	115.5mm
Shank diameter (ØD)	20mm
Trigger direction	±X, ±Y, +Z
Directional trigger protection stroke	X-Y: ±12°, Z: +5mm
Arbitrary one-way repeated trigger accuracy	≤1µm
Trigger force in X-Y direction (with standard styli)	0.3-0.6N
Trigger force in Z direction	4N
Dust/waterproof	IP67
Type-C charging cable	1.5m
Signal extension cord (provide signals to CNC)	1m

signal extension cord (included)



type-C charging cable (included)



application



### STYLI (OPTIONAL)

(mm)

Code	L1	L2	Ød	Material of rod	Material of ball
9410-P1	18	13	4	stainless steel	ruby
9410-P2	18	13.5	5	stainless steel	ruby
9410-P3	18.5	13	3	stainless steel	ruby
9410-P4	19	8	2	carbide	ruby
9410-P5	19.5	4	1	carbide	ruby
9410-P6	50	40	2	carbide	ruby
9410-P7	50	34	5	ceramic	ruby
9410-P8	100	86	6	ceramic	ruby
9410-P9	40	30	4	ceramic	ruby
9410-P10	50	36	6	ceramic	ruby

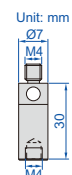
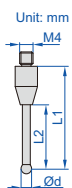

### EXTENSION ROD (OPTIONAL)

Code	Material
9410-R1	ceramic

\* For stainless steel or carbide rods, it is recommended to use extension rods to protect spindles in case of break

# INFRARED TRANSMISSION PROBES FOR CNC MACHINE TOOLS

**IP68**  
WATERPROOF



- On-machine measurement of all kinds of small and medium-sized machining centers, CNC boring, milling machines and five-axis CNC machine tools
- Automatically set the workpiece coordinate and machining reference point before CNC machining process
- Automatically measure dimension and position coordinate during CNC machining
- Measure dimension, shape and position after CNC machining is completed
- Four kinds of SSR signals such as probe status, error, low voltage and pulse are transmitted to CNC machine tools
- M code is used to control on or off of probes
- Infrared transmission, strong anti-interference
- Infrared transmission/reception range: 5m
- Supplied with automatic measurement software
- Optional accessory: styli

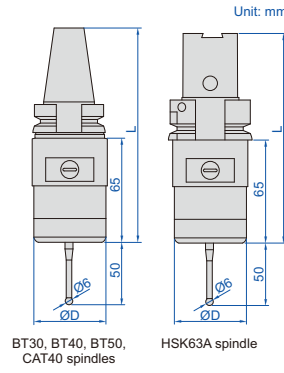

9413-1



9413-A

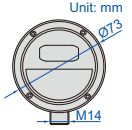

## PROBE SPECIFICATION

Code	9413-1	9413-2	9413-3	9413-4	9413-5
Probe length (L)	140mm	166mm	216mm	168mm	136mm
Probe diameter (ØD)	48mm	48mm	48mm	48mm	48mm
Applicable spindle	BT30	BT40	BT50	CAT40	HSK63A
Trigger accuracy of styli in any direction	1µm				
Protection stroke triggered by styli in all directions	X and Y axis stroke: ±12.5°, Z axis stroke: 5mm				
Trigger force of styli in all directions	X and Y axis: 1-1.6N, Z axis: 5-10N				
Dust/waterproof	IP68				
Power supply	2×LS14250 lithium battery				

\* SK and ISO spindle probes also can be customized



## RECEIVER SPECIFICATION

Code	9413-A
Protection function	low battery voltage or probe transmitting signal all the time**
Applicable probe	code 9413-1, 9413-2, 9413-3, 9413-4, 9413-5
Cable length	8m
Dust/waterproof	IP68
Power supply	input voltage: 24V±10% (DC), load current: 50mA

\*\* When battery voltage is low or probe is in wrong state, receiver sends a signal to CNC machine to stop working

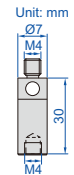

## EXTENSION ROD (OPTIONAL)

Code	Material
9410-R1	ceramic

## STYLI (OPTIONAL)

(mm)

Code	L1	L2	Ød	Material of rod***	Material of ball
9410-P1	18	13	4	stainless steel	ruby
9410-P2	18	13.5	5	stainless steel	ruby
9410-P3	18.5	13	3	stainless steel	ruby
9410-P4	19	8	2	carbide	ruby
9410-P5	19.5	4	1	carbide	ruby
9410-P6	50	40	2	carbide	ruby
9410-P7	50	34	5	ceramic	ruby
9410-P8	100	86	6	ceramic	ruby
9410-P9	40	30	4	ceramic	ruby
9410-P10	50	36	6	ceramic	ruby

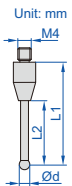

\*\*\* For stainless steel or carbide rods, it is recommended to use extension rods to protect spindles in case of break

## AUTOMATIC MEASUREMENT SOFTWARE (INCLUDED)

1. Stylus automatic calibration
2. Protection of stylus during probe movement (avoid collision)

3. Groove and boss measurement

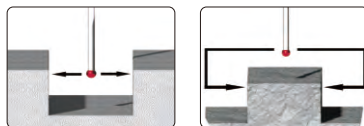

5. X or Y single-surface measurement



7. 4th axis measurement
8. Angle on X and Y plane measurement
9. Three points measurement of arc

4. Bore and axis measurement

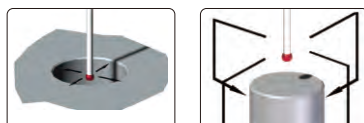

6. Internal and external corner measurement

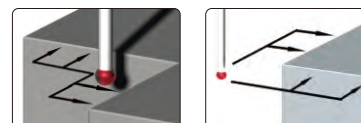

10. Measure the distance between two holes

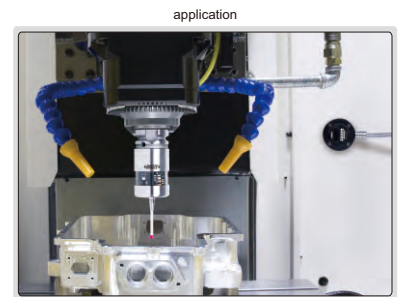

## ZERO SETTER WITH CABLE (FIVE-SIDE) CODE 9412

**IP68**  
WATERPROOF

- Suitable for various machining centers, CNC boring and milling machines, etc.
- Automatically set the tool length parameters before CNC machining process
- Automatic detection of tool wear or damage during CNC machining
- Automatic detection of tool wear or damage after CNC machining is completed
- The working surface adopts ceramic material and chamfering process, which can greatly improve the service life
- The plug, cable part and output signal of the host are protected, so that the zero setter can work in the splash environment for a long time
- Signal transmission through the cable, the reverse connection of the power line can change the state of the signal output
- The working status is displayed by the indicator light
- Supplied with automatic zero setter software package
- Optional accessory: square feeler block (code **9412-B1**)

### SPECIFICATION

Height (factory setting)	80±0.5mm
Diameter of zero setter	Ø12.7mm
Trigger direction	±X, ±Y, +Z
Trigger protection stroke	X-Y: ±5mm, Z: 8mm
Axial reset force	3.4N-3.6N
Repeated trigger accuracy	≤1µm
Hardness of the zero setter	HM8.5
Class of protection	IP68
Cable length *	6m (stainless steel sheath 3m)
Input voltage	24V±10% (DC)
Load current	max: 50mA
Signal type and logic **	SSR (NC/NO)

\*The length of the cable can be customized

\*\* Before purchasing, it is necessary to confirm whether the working logic of the tool setter output signal matches CNC control system

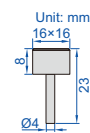
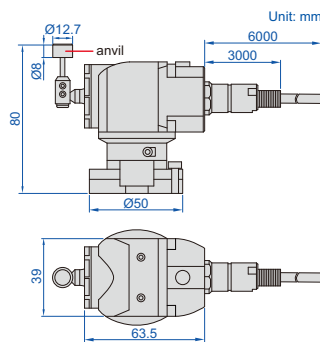

### SQUARE ANVIL (OPTIONAL)

Code	Shape	Dimension	Material
<b>9412-B1</b>	square	16×16mm	ceramic

### Automatic zero setter software (included)

1. Automatic calibration of the center position of the anvil
2. Standard knife length setting
3. Semi-automatic and fully automatic tool setting for tool length
4. Semi-automatic and fully automatic tool diameter settings
5. Automatic detection of tool wear and breakage

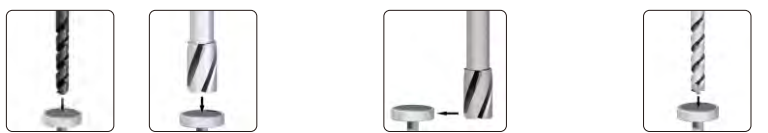

## ZERO SETTER (WITH CABLE) CODE 9411

**IP68**  
WATERPROOF

- Suitable for various machining centers, CNC boring and milling machines, etc.
- Automatically set the tool length parameters before CNC machining process
- Automatic detection of tool wear or damage during CNC machining
- Automatic detection of tool wear or damage after CNC machining is completed
- The working surface is made of hard alloy material, which can greatly improve the scratch resistance
- Signal transmission through the cable, the reverse connection of the power line can change the state of the signal output
- The working status is displayed by the indicator light
- Supplied with 20mm mounting base
- Supplied with automatic zero setter software package
- Optional accessory: blow-cleaning device (code **9411-C1**)

### SPECIFICATION

Height	80mm (the height is 100mm after adding the mounting base)
Diameter of zero setter	Ø25mm
Downward travel	5mm
Axial reset force	6N±0.3N
Repeated trigger accuracy	≤1µm
Hardness of the zero setter	HRA90-93
Class of protection	IP68
Cable length *	6m (stainless steel sheath 3m)
Input voltage	24V±10% (DC)
Load current	max: 50mA
Signal type and logic **	SSR (NC/NO)

\*The length of the cable can be customized

\*\* Before purchasing, it is necessary to confirm whether the working logic of the tool setter output signal matches CNC control system

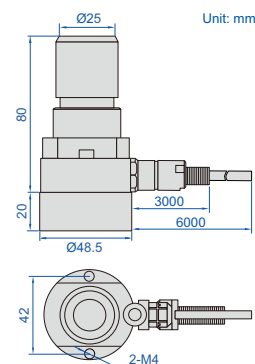

### blow-cleaning device (optional)

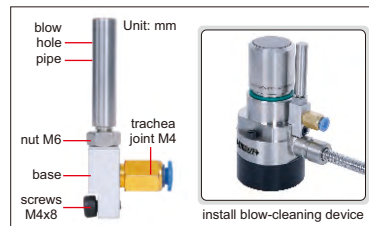

### BLOW-CLEANING DEVICE (OPTIONAL)

Code	Material
<b>9411-C1</b>	stainless steel

Before purchasing a blow-cleaning device, it is necessary to confirm whether CNC machine has the M-code to control the cleaning



### Automatic zero setter software package (included)

1. Automatic calibration of the center position of the cutter block
2. Standard knife length setting
3. Semi-automatic and fully automatic tool setting for tool length
4. Automatic detection of tool wear and breakage

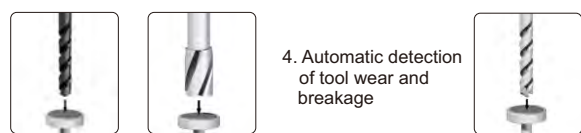

## ELECTRONIC ZERO SETTER

**INSIZE PLUS**  
MADE IN EUROPE

- The base is electrically conducted to the cutting tools through the table and chuck, the LED lights up when the cutting tool touches the anvil
- Magnetic base
- Two batteries LR44

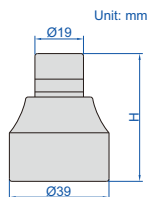

6553-50

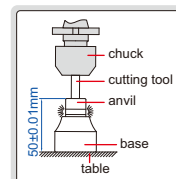

LOW TEST FORCE

Code	Height (H)	Accuracy	Test force
6553-50	50mm	±10µm	7N (at 49mm)

## DIGITAL ZERO SETTER

- Resolution: 0.001mm/0.00005"
- IP65 dust/waterproof
- Buttons: on/off, mm/inch, zero
- CR2032 battery
- Automatic power off
- Magnetic base
- Automatic backlight at zero

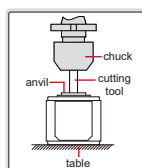
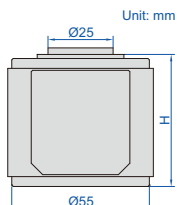

6557-50



IP65  
WATERPROOF

Code	Height (H)	Anvil stroke	Accuracy*	Test force	Repeatability
6557-50	50mm	2.5mm	±10µm/0.0004"	10N (at 50mm)	2µm

\* The accuracy is ensured within Ø10mm of the center

## ZERO SETTER

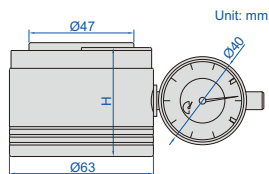
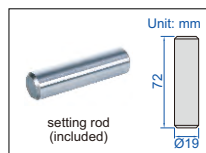

6556-50

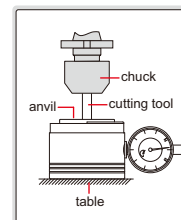

Code	Height (H)	Graduation	Accuracy	Test force
6556-50	50mm	0.01mm	±0.01mm	10N (at 50mm)

## ZERO SETTER

- Magnetic base

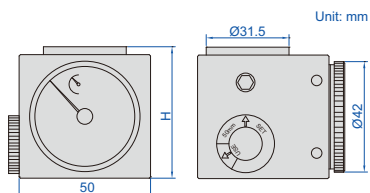

2397-502A

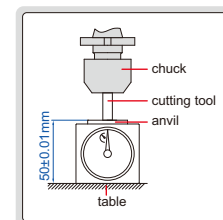

Code	Height (H)	Graduation	Accuracy	Test force
2397-502A	50mm	0.01mm	±0.01mm	9N (at 50mm)

## ZERO SETTER

- Magnetic base with on-off switch
- Test force: 9N (at 100mm)

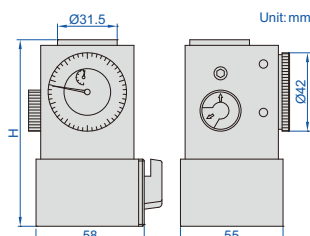

2394-100A

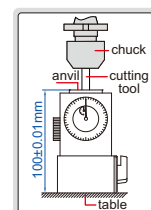

Code	Height (H)	Graduation	Accuracy
2394-100A	100mm	0.01mm	±10µm

## DIGITAL LEVEL CODE ISE-2DT

DATA OUTPUT

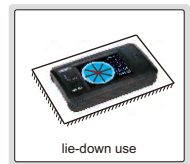

- Color LCD, touch panel
- X-Y axis measurement
- Set the tolerance and the display is shown in different colors

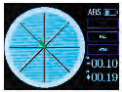

within the tolerance (green)



out of the tolerance (red)



- To show the incline with line or bubble



### SPECIFICATION

Measuring range	±30°
Resolution	0.1°, 0.01°, 0.1mm/m
Accuracy	±0.03° (range 0~3°) ±0.05° (range >3°)
Power supply	rechargeable battery
Dimension	115×66×25mm
Weight	224g

### STANDARD DELIVERY

Main unit	1 pc
USB cable	1 pc

### OPTIONAL ACCESSORY

Software	ISE-2DT-SOFTWARE
----------	------------------

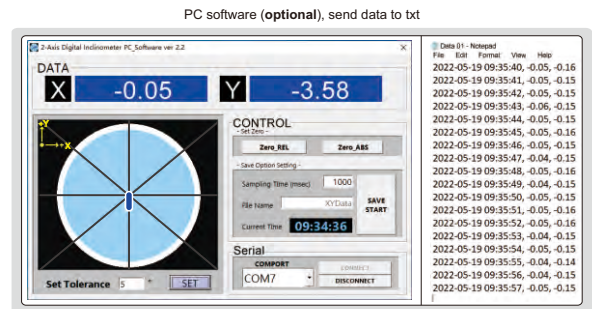

## DIGITAL LEVEL AND SLOPE METER

BACKLIGHT

BUZZER ALARM  
AT 0° AND 90°

WORKING TEMPERATURE  
-5°C~50°C



ABSOLUTE  
LEVEL

IP67  
WATERPROOF



2175-360

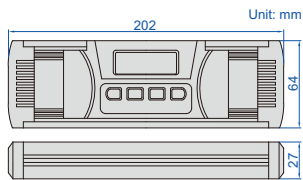

- IP67 dust/waterproof
- Used as level and slope meter
- Aluminum frame, shock absorbing rubber end caps
- Magnetic bottom with V-groove for shafts
- The sea level is permanently set inside the chip, zero setting is not needed when batteries are replaced
- Buttons: ON/OFF, backlight/buzzer alarm, absolute and incremental measurement, unit (mm/m, %, °), HOLD (keep the reading)
- Three AAA batteries, automatic power off

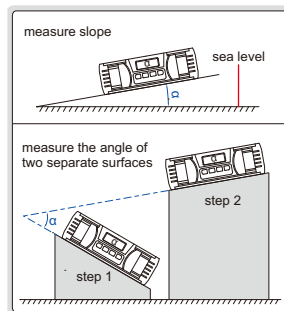

Code	Range	Resolution	Accuracy
2175-360	0-360° (90°x4)	0.05° (=0.873mm/m)	at 0°: ±0.05°; at others: ±0.1°

## DIGITAL LEVEL AND SLOPE METER

BACKLIGHT

BUZZER ALARM  
AT 0° AND 90°

WORKING TEMPERATURE  
-5°C ~ 50°C

IP54  
WATERPROOF

ABSOLUTE  
LEVEL



2179-360

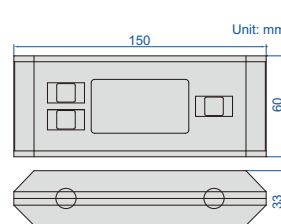

- Resolution: 0.05° (=0.873mm/m)
- IP54 dust/waterproof
- Used as level and slope meter
- Aluminum frame
- Magnetic bottom with V-groove for shafts
- The sea level is permanently set inside the chip, zero setting is not needed when battery is replaced
- Buttons: ON/OFF, absolute and incremental measurement, keep the reading, buzzer alarm, unit (mm/m, %, in/ft), conversion, backlight
- Two AAA batteries, automatic power off

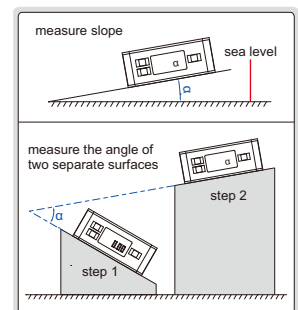

Code	Range	Accuracy
2179-360	0-360°(90°x4)	at 0° and 90°: ±0.1°, at others: ±0.2°



## DUAI AXIS DIGITAL LEVEL AND GYRO ANGLE METER

AUDIBLE ALARM  
WHEN OUT OF LIMIT

DISPLAY FLIPS OVER WHEN  
THE BOTTOM FACES UP

ATTENTION: HARD  
PLASTIC CASE

DATA  
OUTPUT

BACKLIGHT

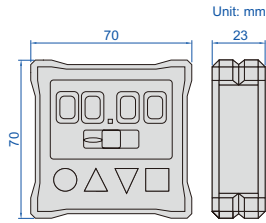
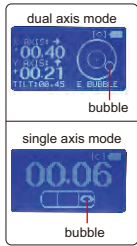

2199-1

M4 threaded holes  
on the back for fixing



measurement of angle between two  
planes in any direction (gyro technique)

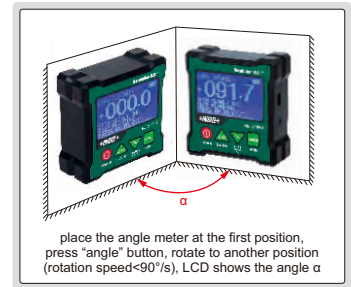

- Single axis/double axis level and slope meter, gyro technique can measure the angle between two planes in any direction
- Hard plastic case, with V-shaped grooves, four magnetic sides
- Display flips over when the bottom faces up
- Audible alarm when out of limit
- Buttons: POWER, ZERO, HOLD, display unit (°, mm/m, %), MENU
- Rechargeable Li-ion battery 3.7V, operation time is 40 hours
- Automatic power off in 30 minutes
- Data output
- Android and iPhone APP are included
- Optional accessory: wired data transmission (code 2199-A01), bluetooth (code 2199-A02), transmission distance is 10 meters (under the condition of no obstruction and no electromagnetic interference)

Code	Range	Resolution	Accuracy
2199-1	single axis level: 4x90° dual axis level: ±40°	0.01°	at 0° and 20°: ±0.08° at 20° and 70°: ±0.15° at 70° and 90°: ±0.08°
	gyro angle meter: 360°	0.1°	±0.5°



horizontal use



vertical use

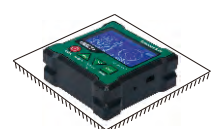

lie-down use

Android and iPhone APP (included), can choose real-time display (continuous transmission) or single transmission



connect to mobile phone via bluetooth



bluetooth (optional)



wired data transmission (optional)



connect to computer via wired data transmission

select continuous or single transmission mode and set tolerance

bubble

single axis and dual axis automatic switching

single transmission

real-time data (display in green when within tolerance and display in red when out of tolerance)

send data clear data

graph

red background (out of tolerance)

green background (within tolerance)

Time	X Value	Y Value	Unit	Alarm
01-19 15:55:01	0.59	-29.86	°	LowMin
01-19 15:54:59	-3.49	-18.28	°	None
01-19 15:54:47	-6.76	-26.90	°	LowMin
01-19 15:54:46	30.22	-13.69	°	None

Time	Value	Unit	Alarm
01-19 15:54:51	71.02	°	LowMax
01-19 15:54:49	71.54	°	LowMax
01-19 15:54:48	71.35	°	LowMax
01-19 15:54:43	41.81	°	None

## DIGITAL LEVEL AND SLOPE METER

DISPLAY FLIPS OVER WHEN  
THE BOTTOM FACES UP

MAGNETIC  
BOTTOM

ABSOLUTE  
LEVEL

WORKING TEMPERATURE  
-5°C-50°C

BACKLIGHT

- Used as level and slope meter
- Aluminum frame, magnetic bottom
- The display flips over when the bottom faces up
- The backlight is on automatically when in use, and automatically off in 15 seconds after use
- The sea level is permanently set inside the chip, zero setting is not needed when battery is replaced
- Buttons: ON/OFF, ZERO, absolute and incremental measurement
- One AAA battery, automatic power off in 5 minutes

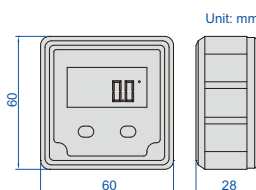

2170-1

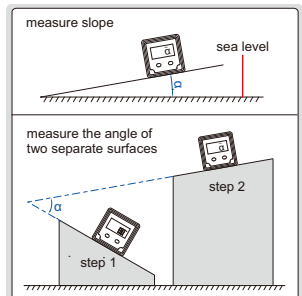

Code	Range	Resolution	Accuracy
2170-1	4x90°	0.1° (=1.745mm/m)	at 0° and 90°: ±0.1°, at others: ±0.2°



## BLUETOOTH DIGITAL LEVEL AND SLOPE METER

WORKING TEMPERATURE  
-5°C~50°C

MAGNETIC  
BOTTOM

DISPLAY FLIPS OVER WHEN  
THE BOTTOM FACES UP

BACKLIGHT

ABSOLUTE  
LEVEL

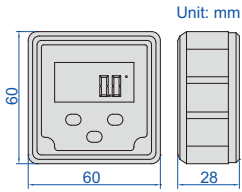

2198-2



Android and iPhone APP (included), can choose real-time display (continuous transmission) or single transmission

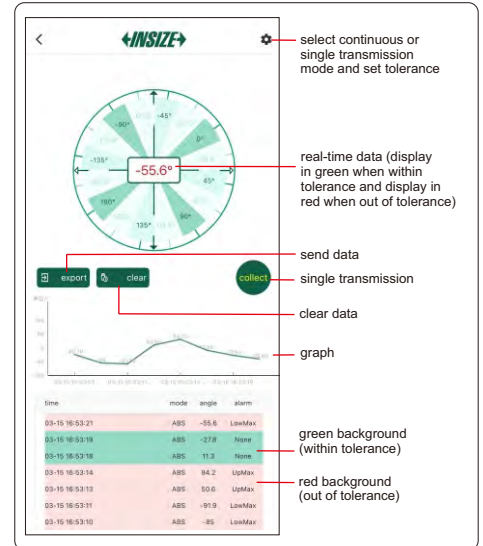

- Used as level and slope meter
- Aluminum frame
- Magnetic bottom
- The display flips over when the bottom faces up
- The backlight is on automatically when in use, and automatically off in 15 seconds after use
- The sea level is permanently set inside the chip, zero setting is not needed when battery is replaced
- Buttons: ON/OFF, ZERO, HOLD, absolute and incremental measurement
- Built-in bluetooth, transmission distance is 15 meters (under the condition of no obstruction and no electromagnetic interference). Android and iPhone APP are included
- One AAA battery, automatic power off in 5 minutes

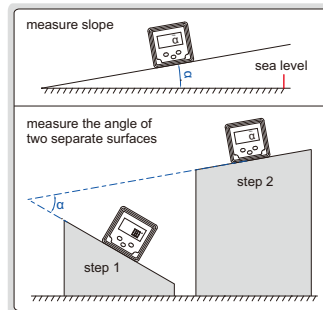

Code	Range	Resolution	Accuracy
2198-2	4x90°	0.1° (=1.745mm/m)	at 0° and 90°: ±0.1°; at others: ±0.2°

## FRAME LEVELS



4902-200

- V-groove on bottom and left for shafts (shafts dia. 15~68mm)
- With transverse vial

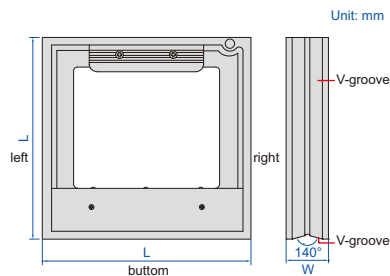

Code	Sensitivity	Size (LxL)	W
4902-150	0.02mm/m (=0.001°)	150x150mm	40mm
4902-200	0.02mm/m (=0.001°)	200x200mm	40mm
4902-300	0.02mm/m (=0.001°)	300x300mm	45mm
4902-C150	0.05mm/m (=0.0029°)	150x150mm	40mm
4902-C200	0.05mm/m (=0.0029°)	200x200mm	40mm
4902-C300	0.05mm/m (=0.0029°)	300x300mm	45mm

## BLOCK LEVELS



POPULAR  
MODEL



4903-200A

- V-groove on bottom for shafts (shafts dia. 15~68mm)
- With transverse vial

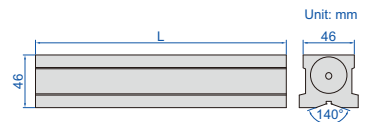

Code	Sensitivity	Length (L)
4903-150A	0.02mm/m (=0.001°)	150mm
4903-200A	0.02mm/m (=0.001°)	200mm
4903-300A	0.02mm/m (=0.001°)	300mm
4903-C150	0.05mm/m (=0.0029°)	150mm
4903-C200	0.05mm/m (=0.0029°)	200mm
4903-C300	0.05mm/m (=0.0029°)	300mm

## DIGITAL LEVELS AND SLOPE METERS

**WORKING TEMPERATURE**  
0°C ~ 50°C



**BACKLIGHT**

**ABSOLUTE LEVEL**

- With transverse and longitudinal vials
- Used as level and slope meter
- Aluminum frame, magnetic bottom
- The sea level is permanently set inside the chip, zero setting is not needed when batteries are replaced
- Buttons: ON/OFF, absolute and incremental measurement, keep the reading, buzzer alarm (not for 4910-400), unit (mm/m, %, in/ft), conversion (not for 4910-400), backlight
- The display flips over when the bottom faces up
- Two AAA batteries, automatic power off



4910-400



4910-600

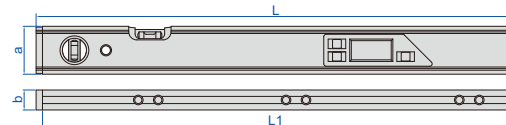
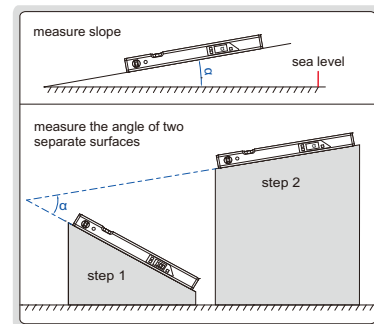

Code	Range	Resolution	Accuracy	Remark	L	L1	a	b
4910-400	0~360° (90°×4)	angle: 0.1°; slope: 1mm/m	±0.2°	both angle and slope are displayed	416mm	400mm	50mm	21mm
4910-600	0~360° (90°×4)	at 0° and 90°: 0.05° (=0.8725mm/m); at others: 0.1° (=1.745mm/m)	at 0° and 90°: ±0.1°; at others: ±0.2°	at 0° and 90° buzzer alarms	600mm	585mm	60mm	25mm

## HANDY LEVEL



4912-100

**MAGNETIC BASE**

**LIFETIME WARRANTY VIALS**

packaging

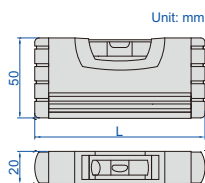

- Shockproof vials
- Magnetic base
- Shock absorbing rubber end caps
- Working temperature: -15°C~55°C

magnetic base surface



Code	Size (L)	Accuracy
4912-100	100mm	0.5mm/m

## CASTING ALUMINUM LEVEL



4913-250

**LIFETIME WARRANTY VIALS**

**MAGNETIC BASE**

packaging



magnetic bottom surface (milled)



- Shockproof horizontal and vertical vials
- Magnetic base
- Working temperature: -15°C~55°C
- Cast aluminum body

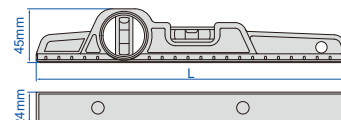

Code	Size (L)	Accuracy
4913-250	250mm	0.5mm/m

## ALUMINUM LEVELS

**LIFETIME WARRANTY VIALS**

**MAGNETIC BASE**



4914-600

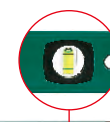
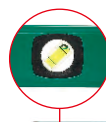

4914-2000

- Accuracy: 0.5mm/m
- Shockproof horizontal and vertical vials
- Magnetic base
- Shock absorbing rubber end caps
- Working temperature: -15°C~55°C

magnetic bottom surface (milled)



Code	Size (L)	Number of vials
4914-300	300mm	2
4914-600	600mm	2
4914-800	800mm	2
4914-1000	1000mm	2
4914-1200	1200mm	2
4914-2000	2000mm	3

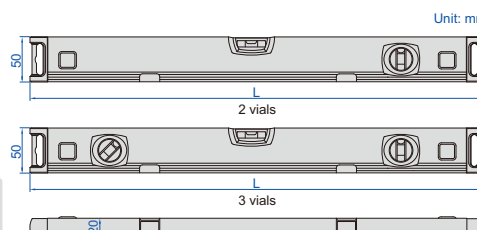

## ALUMINUM LEVELS



4911-600

LIFETIME WARRANTY VIALS

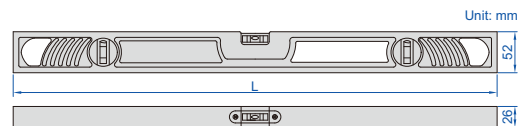

Code	Length (L)	Accuracy
4911-600	600mm	0.5mm/m
4911-800	800mm	0.5mm/m

- Top and bottom working surfaces
- Shock-proof and UV-proof vials
- Die casting aluminum alloy frame
- Zero position of horizontal vial can be set
- One graduation of horizontal vial is 2% slope
- Working temperature: -15°C~55°C

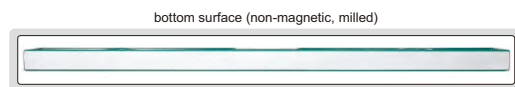

## ALUMINUM LEVELS (BASIC TYPE)



4918-300

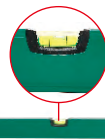

4918-2000

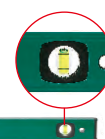

LIFETIME WARRANTY VIALS

MAGNETIC BASE

Code	Size (L)	Number of vials
4918-300	300mm	2
4918-600	600mm	2
4918-800	800mm	2
4918-1000	1000mm	2
4918-1200	1200mm	2
4918-2000	2000mm	3

- Accuracy: 1mm/m
- Shock-proof and UV-proof vials
- Magnetic base
- Shock absorbing rubber end caps
- Working temperature: -15°C~55°C

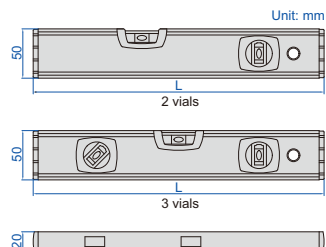
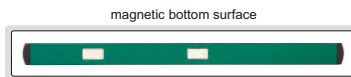

## CROSS-LINE LASER LEVEL CODE 4917-30

- Red horizontal and vertical cross laser lines
- Self-leveling within  $\pm 3^\circ$ , self-leveling time within 4s, audible and visual warning when out of  $\pm 3^\circ$
- Folding legs for angle and height adjustment
- Outdoor use with the detector (code: 4917-DETECTOR)

application examples



IP54 WATERPROOF

AUDIBLE AND VISUAL ALARM WHEN OUT OF  $\pm 3^\circ$

folding legs for angle and height adjustment

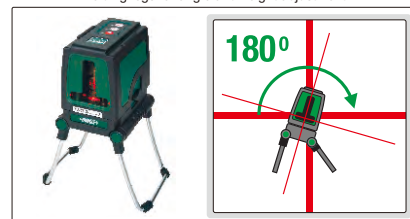

outdoor detector (optional)

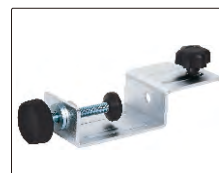

stand (included with outdoor detector)



VIDEO

### SPECIFICATION

Laser line width	2 $\pm$ 0.5mm (within 5m)
Laser type	630~660nm, class II, <1mW
Beam angle	120 $\pm$ 0.5°
Self-leveling range	$\pm 3^\circ$
Working distance	indoor: 30m, outdoor: 50m with detector (optional)
Accuracy	0.2mm/m
Operation temperature	-10~40°C
Power supply	3 $\times$ AA batteries, for 3 hours working
Dimension	100 $\times$ 82 $\times$ 104mm
Weight	620g

### STANDARD DELIVERY

Main unit	1 pc
1/4" to 5/8" tripod adaptor	1 pc
Battery (AA)	3 pcs

### OPTIONAL ACCESSORY

Outdoor detector	4917-DETECTOR
------------------	---------------

### OUTDOOR DETECTOR (OPTIONAL)

Detecting distance	horizontal 1~50m, vertical 1~30m
Detecting accuracy*	high accuracy $\pm 1.5$ mm, low accuracy $\pm 2.5$ mm
Power supply	9V battery
Dimension	168 $\times$ 58 $\times$ 30mm
Weight	140g (battery included)

\*Use high accuracy detection mode within 15m, use low accuracy detection mode over 15m

## SELF-LEVELING ROTARY LASER CODE GRL-L340



INDICATOR FLASHING  
WHEN OUT OF  $\pm 5^\circ$

IP65  
WATERPROOF

application examples



horizontal leveling

vertical leveling

working with detector



detector (included)



remote controller (included)



beam finder glasses (included)



bracket for C battery (included)



tripod (included)

### SPECIFICATION

Working range	indoor 50m, outdoor 300m (with detector)	
Self leveling range	$\pm 5^\circ$	
Horizontal/vertical beam accuracy	$\pm 0.1\text{mm/m}$	
Main laser type	520~540nm, class 2, <1mW	
Auxiliary laser type	645~655nm, class 2, <1mW	
Rotating speed	0/60/120/300/600rpm	
Scanning range	0/10/45/90/180/360°	
Setting slope	X axis: $\pm 5^\circ$ , Y axis: $\pm 5^\circ$	
Operation temperature	-20~50°C	
Maximum remote control distance	20m	
Power supply	remote controller	2x1.5V AAA batteries
	main unit	NI-MH batteries or 4x1.5V C batteries
	detector	1x9V battery
Dimension	210x210x213mm	
Weight	2.5kg	

- Applicable fields: construction, decoration, pipeline and equipment installation
- Green laser beam rotates 360° horizontally or vertically
- Self-leveling range  $\pm 5^\circ$  on both X and Y planes
- Alarm when inclination is out of  $\pm 5^\circ$
- $\pm 5^\circ$  leveling range for manual mode on both X and Y planes
- 5 variable speeds 0-600rpm
- 6 scan modes
- Plumb up and plumb down dots
- Remote control for long distance
- Power supply: AC or DC

### STANDARD DELIVERY

Main unit (including NI-MH batteries)	1 pc
C battery and bracket	1 set
Detector	1 pc
Remote controller	1 pc
Beam finder glasses	1 pc
Laser target	1 pc
Power adapter	1 pc
AAA battery	2 pcs
9V battery	1 pc
Tripod	1 pc

## DIGITAL HORIZONTAL SCALES

DATA  
OUTPUT



7101-300A



7101-400A

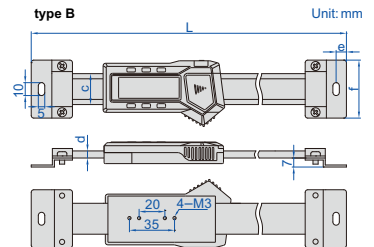
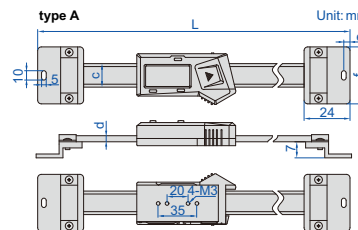

- Non waterproof
- Resolution: 0.01mm/0.0005"
- Buttons type A: on/off, zero, mm/inch,  
type B: on/off, zero, mm/inch, ABS, data preset
- Automatic power off, move the digital unit to turn on power
- Battery CR2032
- Data output
- Made of stainless steel
- Supplied with bracket to be mounted on the back

example of application

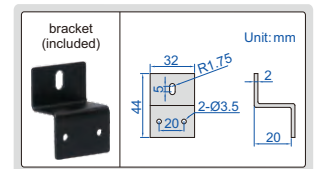
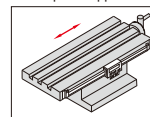

Code	Range	Type	Accuracy	L	c	d	e	f	Data output cable (optional)
7101-100A	100mm	A	$\pm 0.02\text{mm}$	215mm	16mm	4mm	6mm	36mm	7315-21 need receiver, 7302-21, 7305-21
7101-150A	150mm	A	$\pm 0.03\text{mm}$	265mm	16mm	4mm	6mm	36mm	7315-21 need receiver, 7302-21, 7305-21
7101-200A	200mm	A	$\pm 0.03\text{mm}$	315mm	16mm	4mm	6mm	36mm	7315-21 need receiver, 7302-21, 7305-21
7101-300A	300mm	A	$\pm 0.04\text{mm}$	445mm	16mm	4mm	6mm	36mm	7315-21 need receiver, 7302-21, 7305-21
7101-400A	400mm	B	$\pm 0.05\text{mm}$	590mm	24mm	5.5mm	8mm	45mm	7315-22 need receiver, 7302-22, 7305-22
7101-500A	500mm	B	$\pm 0.05\text{mm}$	690mm	24mm	5.5mm	8mm	45mm	7315-22 need receiver, 7302-22, 7305-22
7101-600A	600mm	B	$\pm 0.08\text{mm}$	790mm	24mm	5.5mm	8mm	45mm	7315-22 need receiver, 7302-22, 7305-22
7101-800A	800mm	B	$\pm 0.10\text{mm}$	990mm	24mm	5.5mm	8mm	45mm	7315-22 need receiver, 7302-22, 7305-22
7101-1000A	1000mm	B	$\pm 0.10\text{mm}$	1240mm	31mm	10.5mm	10mm	60mm	7315-22 need receiver, 7302-22, 7305-22

## LINEAR SCALES (TTL SIGNAL)



ISL-A1-300

- Optical TTL (Through-The-Lens) detection. These optical TTL linear scales use a transistor logic to transmit and record high-resolution distance measurements. They are the most accurate type of encoder and are paired with ISL-DR2/DR3 and ISL-LCD7 (digital readout)

Series ISL-A1 and ISL-A5

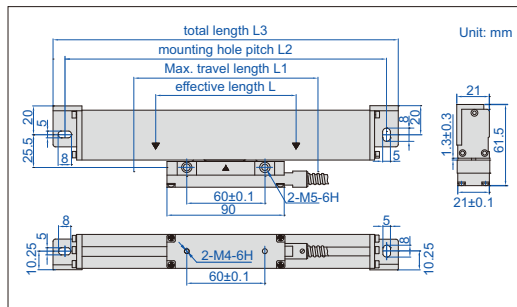

Series ISL-B5

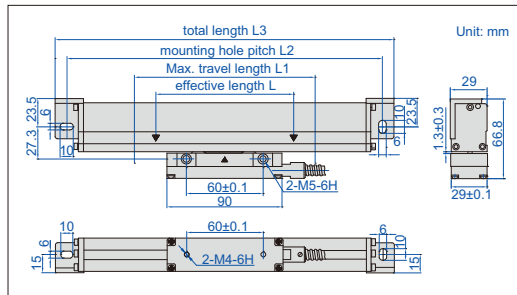

Effective length (L)	Code		
	thin type		thick type
	series ISL-A1	series ISL-A5	series ISL-B5
50mm	ISL-A1-50	ISL-A5-50	ISL-B5-50
100mm	ISL-A1-100	ISL-A5-100	ISL-B5-100
150mm	ISL-A1-150	ISL-A5-150	ISL-B5-150
200mm	ISL-A1-200	ISL-A5-200	ISL-B5-200
250mm	ISL-A1-250	ISL-A5-250	ISL-B5-250
300mm	ISL-A1-300	ISL-A5-300	ISL-B5-300
350mm	ISL-A1-350	ISL-A5-350	ISL-B5-350
400mm	ISL-A1-400	ISL-A5-400	ISL-B5-400
450mm	ISL-A1-450	ISL-A5-450	ISL-B5-450
500mm	ISL-A1-500	ISL-A5-500	ISL-B5-500
550mm	ISL-A1-550	ISL-A5-550	ISL-B5-550
600mm	ISL-A1-600	ISL-A5-600	ISL-B5-600
650mm	ISL-A1-650	ISL-A5-650	ISL-B5-650
700mm	ISL-A1-700	ISL-A5-700	ISL-B5-700
750mm	ISL-A1-750	ISL-A5-750	ISL-B5-750
800mm	ISL-A1-800	ISL-A5-800	ISL-B5-800
850mm	ISL-A1-850	ISL-A5-850	ISL-B5-850
900mm	ISL-A1-900	ISL-A5-900	ISL-B5-900
950mm	ISL-A1-950	ISL-A5-950	ISL-B5-950
1000mm	ISL-A1-1000	ISL-A5-1000	ISL-B5-1000
1100mm			ISL-B5-1100
1200mm			ISL-B5-1200
1300mm			ISL-B5-1300
1400mm			ISL-B5-1400
1500mm			ISL-B5-1500
1600mm			ISL-B5-1600
1700mm			ISL-B5-1700
1800mm			ISL-B5-1800
1900mm			ISL-B5-1900
2000mm			ISL-B5-2000

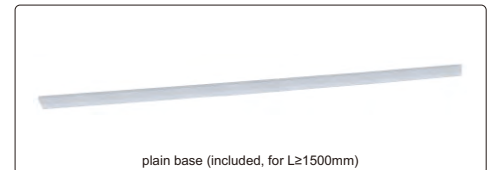
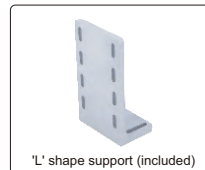

### STANDARD DELIVERY

Main Unit	1 pc
'L' shape support	1 pc
Anti-dust cover	1 pc
Plain base	1 pc (for L≥1500mm)
Mounting accessories	1 package

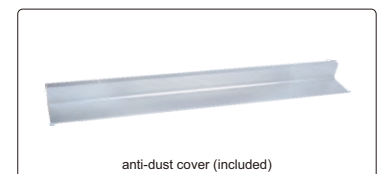
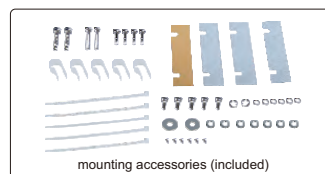

### SPECIFICATION

Code	Series ISL-A1		Series ISL-A5		Series ISL-B5	
L1 (mm)	L+30 (L≤900)	L+50 (L>900)	L+30 (L≤900)	L+50 (L>900)	L+30 (L≤900)	L+50 (L>900)
L2 (mm)	L+132 (L≤900)	L+152 (L>900)	L+132 (L≤900)	L+152 (L>900)	L+136 (L≤900)	L+156 (L>900)
L3 (mm)	L+148 (L≤900)	L+168 (L>900)	L+148 (L≤900)	L+168 (L>900)	L+154 (L≤900)	L+174 (L>900)
Resolution	1μm		5μm		5μm	
Max. response speed	50m/min		90m/min		60m/min	
Scale grating pitch	20μm					
Scale reference point pitch	50mm					
Accuracy	±(5+5L/1000)μm L is the effective length in mm					
Cable length	3.5m (L: 50-950mm), 5m (L: 1000-1500mm), 10m (L: 1600-2000mm)					
Output signal	TTL					
Socket	9PD					
Power supply	5±0.5V					

## DIGITAL READOUTS



VIDEO

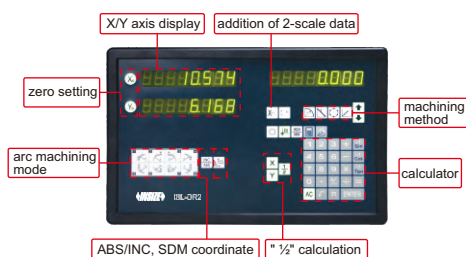

ISL-DR2

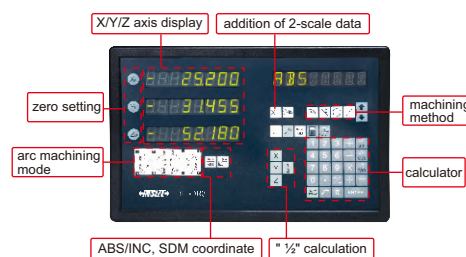

ISL-DR3

- For ISL-A1, ISL-A5, ISL-B5 series linear scales



software flash disk (included)



mounting bracket (included)

### SPECIFICATION

Code	ISL-DR2	ISL-DR3
Application	two-axis	three-axis
Scale input ports	2	3
Resolution	0.05μm, 0.1μm, 0.2μm, 0.5μm, 1μm, 2μm, 5μm, 10μm, 20μm, 50μm	
Functions	addition of 2-scale data, linearity error compensation, smoothing, RS232C interface unit, BCD code out, zero setting, preset, resolution setting, counting direction setting, inch/mm conversion, ABS/INC conversion, expansion/contraction coefficient setting, "1/2" calculation, detecting RI, bolt-hole circle machining, ramp circle machining	
Power supply	110/220V, 50/60Hz	
Dimension	295x185x45mm	
Weight	1.45kg	

### STANDARD DELIVERY

Main unit	1 pc
Mounting bracket	1 pc
Ground cable	1 pc
RS232C cable	1 pc
Software flash disk for RS232C	1 pc

## DIGITAL READOUT CODE ISL-LCD7



VIDEO

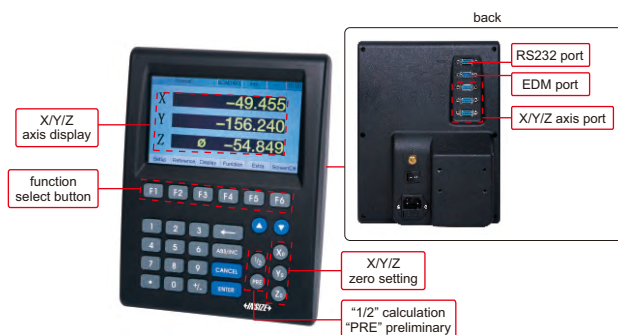

- 7.57 inch LCD display
- Language: English, Simplified Chinese, Traditional Chinese
- Can be connected with ISL-A1, ISL-A5, ISL-B5 series linear scales

### READOUT SPECIFICATION

Application	three-axis: X/Y/Z
Scale input ports	3
Resolution	0.05μm, 0.1μm, 0.2μm, 0.5μm, 1μm, 2μm, 5μm, 10μm, 20μm, 50μm
Functions	X/Y/Z addition of 3-scale data, linearity error compensation, smoothing, RS232C interface unit, BCD code out, zero setting, preset, resolution setting, counting direction setting, inch/mm conversion, ABS/INC conversion, expansion/contraction coefficient setting, "1/2" calculation, detecting RI, bolt-hole circle machining, ramp circle machining, circular arc machining, oblique surface machining, automatic edge finding, discharge machining
Dimension	200×88×260mm
Weight	1.26kg



mounting bracket for readout (included)



### STANDARD DELIVERY

Main unit	1 pc
Mounting bracket	1 pc
Ground cable	1 pc
RS232C cable	1 pc
Software flash disk for RS232C	1 pc

## LASER SCAN MICROMETERS

- Measure outer diameter, ellipticity, run-out, maximum diameter of tools, etc.
- Can be used for transparent or non transparent workpieces
- Tolerance measurement
- Online or offline measurement
- Connected with computer, PLC, control box

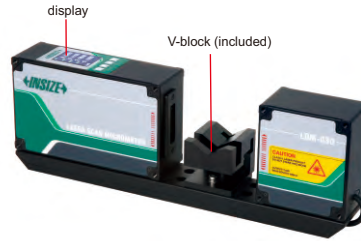

LDM-030

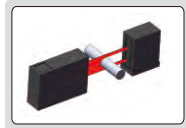
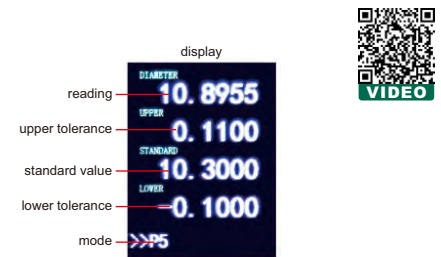

measure external diameter



two-axis measurement

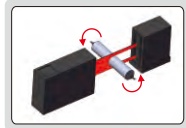

measure ellipticity and run-out

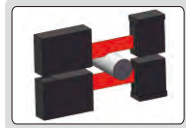

large size measurement



calibration gage (optional)



connect to control box (optional)

### SPECIFICATION

Code	LDM-030	LDM-065
Measuring range	0.1~30mm	0.5~65mm
Resolution	0.01/0.1/1/10/100μm selectable	
25°C accuracy	±(0.5+10%D)μm, D is measuring diameter in mm	
Repeatability	±(0.3+5%D)μm, D is measuring diameter in mm	
Laser wave length	650nm	
Measuring speed	800~3200times/s (adjustable)	
Operation temperature	0~50°C	
Operation humidity	35~85RH without condensation	
Output	dual channel RS485	
Alarm output	24V, 1A	
Power supply	DC24V, 2A	
Dimension (L×W×H)	351×52×120mm	469×52×156mm
Weight	5kg	8kg

### Dimension (mm)

Code	LDM-030	LDM-065
L	351	469
W	52	52
H	120	146
L1	170	203
L2	95	131

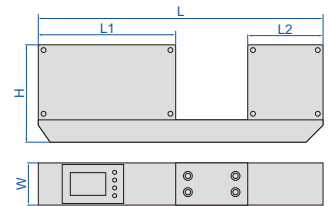

### STANDARD DELIVERY

Main unit	1 pc
V-block	1 pc
AC/DC adapter	1 pc
RS485 cable	1 pc

### OPTIONAL ACCESSORY

Calibration gage	custom made
Control box	custom made

## TOOL PRESETTER (BASIC TYPE) CODE TLP-300H



rotate tools



standard rod (included)



### SPECIFICATION

Maximum tool diameter (X axis)	Ø300mm
Height measuring range	60~300mm
Repeatability	0.005mm
Measuring accuracy	0.02mm
Linear scale resolution	0.005mm
Dial indicator graduation	0.01mm
Spindle holder	BT50
Power supply	110/220V, 50/60HZ
Dimension (L×W×H)	600×365×690mm
Weight	68kg

### STANDARD DELIVERY

Main unit	1 pc
BT50 spindle holder	1 pc
Standard rod	1 pc
Dial indicator	2 pcs
Wrench	1 set
Anti-dust cover	1 pc

### OPTIONAL ACCESSORY

BT50/BT30 converter	TLP-300H-C1
BT50/BT40 converter	TLP-300H-C2

- Absolute linear scales, zero setting is not needed after power on and off



BT50/BT40 converter (optional)



BT50/BT30 converter (optional)



## DIGITAL ULTRASONIC FLAW DETECTOR CODE UFD-T680



- The all-aluminum metal shell is strong and durable, and the electromagnetic shielding performance is very good
- Tempered glass panel, extremely hard, wear-resistant and scratch-resistant
- Full-digital multi-color high resolution (640×480 pixels) TFT LCD display
- 4 operation interface styles can be selected according to the environment
- Real-time screenshots of all pages and flaw detection reports, and save them as BMP pictures to U disk
- Export the flaw detection report as a PDF file
- Unique Fn multifunction key design
- There is no limit of the number and duration of video recording through U disk
- Memory of 500 channel files to store calibration setups and probe parameter
- Memory of 1000 wave report files to store A-Scan wave and settings
- Two fully independent gates offer a range of measurement options for signal height or distance using peak triggering
- Can choose to set the incoming wave alarm or lost wave alarm, accompanied by LED light display
- Selectable frequency ranges (automatically set by the instrument) to match probe for optimum performance
- The unique automatic gain adjustment and gain scanning function make flaw detection fast and accurate

### FUNCTIONS

<b>Flaw detection standard</b>	built-in common flaw detection standards, direct call, convenient and fast
<b>Auto calibration</b>	automatic calibration of probe zero offset, probe angle (K value) and material velocity
<b>Peak hold</b>	compare frozen peak waveforms to live A-Scans to easily interpret test result
<b>Flaw locating</b>	live display sound-path, projection (surface distance), depth, amplitude
<b>Flaw discrimination</b>	automatic flaw sizing using AVG or DAC, speeds reporting of defect acceptance or rejection
<b>Flaw sizing</b>	the equivalent dB value of defects or equivalent size of defects are displayed in real time
<b>Curved surface correction</b>	used for flaw detection of curved workpiece, it can display the circumferential position of defects in real time
<b>DAC/AVG</b>	the curve is automatically generated, and the sampling points can be compensated and corrected. The curve automatically floats with the gain, automatically expands with the detection distance, and automatically moves with the delay time. It can display the AVG curve of any aperture
<b>AWS D1.1</b>	choosing this standard can reduce manual calculations and improve detection efficiency
<b>Weld diagram</b>	support V type, T type, L type and other weld types, acoustic path navigation real-time display, weld and defect location real-time display, scaling, easy to locate defects
<b>Automatic rating</b>	select different AWS standards, automatically calculate the rating of defects and display
<b>Crack height</b>	the crack height is measured and calculated automatically by the diffracted wave at the end
<b>Gate magnify</b>	spreading of the gate range over the entire screen width
<b>Continuous record</b>	video recording and playback
<b>Echo coding</b>	display 1~9 echo display area in different colors, used to analyze the defect position
<b>Scan freeze</b>	display freeze holds waveform and test distance data
<b>Peak mark</b>	capture and mark the peak in real time
<b>B scan</b>	intuitively display the defect shape of the workpiece and the detection result is more intuitive

### SPECIFICATION

<b>Measuring range</b>	0~15000mm
<b>Working frequency</b>	0.2~20MHz
<b>Material velocity</b>	100~20000m/s
<b>Repetition frequency</b>	20~2000Hz
<b>Dynamic range</b>	≥36dB
<b>Vertical linearity</b>	≤1.5%
<b>Horizontal linearity</b>	≤0.1%
<b>Resolving power</b>	>42dB
<b>Sensitivity leavings</b>	>65dB
<b>Suppression</b>	0~80%
<b>Noise</b>	≤10%
<b>Probe selection</b>	single crystal probe, dual crystal probe, penetrating probe, climbing probe
<b>Pulse energy</b>	100V, 200V, 250V, 300V, 350V, 400V, 450V, 500V (selectable)
<b>Pulse width</b>	30ns-51ns
<b>Probe damping</b>	50Ω, 150Ω, 250Ω, 500Ω (selectable)
<b>Rectification</b>	positive half wave, negative half wave, full wave, RF
<b>Gates</b>	two independent gates controllable over entire sweep range
<b>Interface</b>	USB 2.0
<b>Operation temperature</b>	-10~50°C
<b>Relative humidity</b>	20~95%RH
<b>Power</b>	build-in rechargeable battery
<b>Size</b>	263×170×61mm
<b>Weight</b>	1.92kg



angle-beam probe (included)



straight-beam probe (included)



USB disk (included)



couplant (included)

### STANDARD DELIVERY

<b>Main unit</b>	1 pc
<b>Single-element straight probe UFD-T60</b>	1 pc
<b>Single-element angle probe UFD-T61</b>	1 pc
<b>USB cable</b>	1 pc
<b>Couplant</b>	1 bottle
<b>Probe connecting cable</b>	1 pc
<b>USB disk</b>	1 pc
<b>Power adapter</b>	1 pc

### SPECIFICATION OF PROBE

Code	Frequency	Size	Probe type	Transducer sensor angle
<b>UFD-T60 (included)</b>	2.5MHz	Ø20mm	single-element straight probe	90°
<b>UFD-T61 (included)</b>	4.0MHz	8x9mm	single-element angle probe	60°
<b>UFD-T62 (optional)</b>	5.0MHz	Ø10mm	dual-element straight probe	90°
<b>UFD-T63 (optional)</b>	5.0MHz	Ø10mm	single-element straight probe	90°
<b>UFD-T64 (optional)</b>	4.0MHz	8x9mm	single-element angle probe	45°
<b>UFD-T65 (optional)</b>	4.0MHz	8x9mm	single-element angle probe	70°

Note: Other types of the probes are available

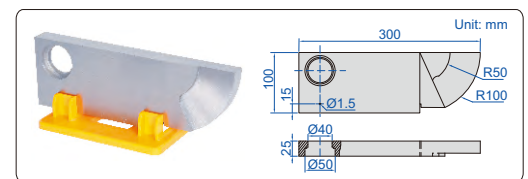

calibration block (optional)

### OPTIONAL ACCESSORY

<b>Calibration block</b>	<b>UFD-CSK1</b>
--------------------------	-----------------

### JIGS FOR CMM (ANVIL Ø6mm)

CAN BE CUSTOMIZED

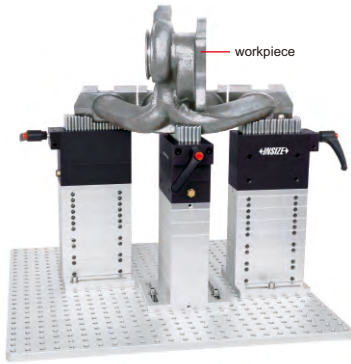

ISY-400



ISY-400-1



ISY-400-2



ISY-400-3



ISY-400-4



ISY-400-5



ISY-400-6

Code	Product	Remark
ISY-400	jig set	including 3 pcs ISY-400-1, 9 pcs ISY-400-2, 9 pcs ISY-400-3, 1 pc ISY-400-4, 3 pcs ISY-400-5, 3 pcs ISY-400-6

(mm)

Code	Product	Size	Anvil area	Anvil stroke
ISY-400-1	spring anvil	135×60×90	36×100	24

Code	Product	Size (mm)
ISY-400-2	block	120×60×20
ISY-400-3	block	120×60×30
ISY-400-4	base plate	500×500×12
ISY-400-5	connecting plate	130×120×12
ISY-400-6	clamp handle	—

### JIGS FOR CMM (ANVIL Ø6mm)

CAN BE CUSTOMIZED

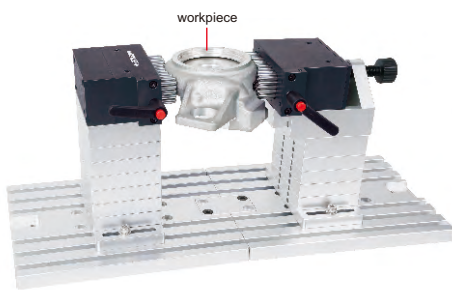

ISY-500



ISY-500-1



ISY-500-2



ISY-500-3



ISY-500-4



ISY-500-5



ISY-500-6



ISY-500-7

Code	Product	Remark
ISY-500	jig set	including 1 pc ISY-500-1, 1 pc ISY-500-2, 2 pcs ISY-500-3, 10 pcs ISY-500-4, 2 pcs ISY-500-5, 1 pc ISY-500-6, 2 pcs ISY-500-7

(mm)

Code	Product	Size	Anvil area	Anvil stroke
ISY-500-1	spring anvil	134×90×90	36×100	24
ISY-500-2	adjustable spring anvil (range 0-40mm)	134×120×130	36×100	24

Code	Product	Size (mm)
ISY-500-3	base plate	300×240×20
ISY-500-4	block	120×90×20
ISY-500-5	connecting plate	170×90×15
ISY-500-6	connecting block of base plate	80×50×10
ISY-500-7	clamp handle	—

# JIG SET FOR CMM CODE ISY-100

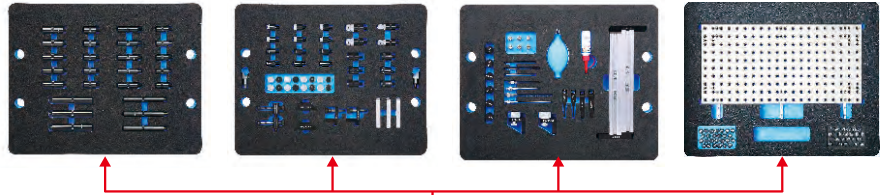

ISY-100

application examples

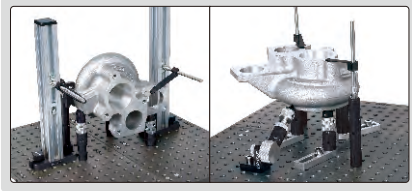





Product	Code	Size (mm)	Quantity	Application
stand	ISY-100-1001	Ø16×30	5	
	ISY-100-1002	Ø16×50	5	
	ISY-100-1003	Ø16×100	3	
stand	ISY-100-1004	Ø20×30	5	
	ISY-100-1005	Ø20×50	5	
	ISY-100-1006	Ø20×100	3	
stand with fine adjustment	ISY-100-2001	Ø16×45~60	2	height adjustment: 45~60mm
stand with fine adjustment	ISY-100-2003	Ø20×45~60	2	
horizontal spring stand	ISY-100-4001	—	2	
horizontal screw stand	ISY-100-5001	—	2	
magnetic stand (magnetic top surface)	ISY-100-7001	Ø20×25	3	
stand for slice parts	ISY-100-8001	Ø20×25	2	<b>ISY-100-8001</b> and <b>ISY-100-8002</b> use cooperatively
clamping stand for slice parts	ISY-100-8002		1	
clip	ISY-100-1201	—	2	
clip	ISY-100-1301	—	2	
clip stand	ISY-100-1401	Ø6×60	2	
	ISY-100-1402	Ø6×100	2	
vertical square column	ISY-100-3003	30×30×250	2	





Product	Code	Size (mm)	Quantity	Application
sliding support plate	ISY-100-1801	78×20×10	3	
clamping screw	ISY-100-2301	Ø8×20	6	
screw	ISY-100-2302	Ø8×20	6	
base plate	ISY-600-400200	400×400×12 hole size: M8×1.25 hole center distance: 20	2 pieces	—
wrench	ISY-100-3701	Ø3.8×70	1	—
wrench	ISY-100-3801	M2.5	1	—
	ISY-100-3802	M5	1	—
	ISY-100-3803	M6	1	—
45° stand	ISY-100-9001	—	2	
V shaped support	ISY-100-1901	—	2	
V shaped support	ISY-100-1902	—	2	
marker	ISY-6100-1501	—	52*	
dust cleaner	ISY-100-3501	—	1	—
lubricating oil	ISY-100-3601	—	1	—

\* Letter A~Z, number 0~25

To be continued

Continued from previous page

Product	Code	Quantity	Material	Application
	ISY-100-27016	2	aluminum	
	ISY-100-27018	2	nylon	
	ISY-100-27026	2	aluminum	
	ISY-100-27028	2	nylon	
	ISY-100-27036	2	aluminum	
	ISY-100-27038	2	nylon	

Product	Code	Quantity	Material	Application
	ISY-100-27046	2	aluminum	
	ISY-100-27048	2	nylon	
	ISY-100-27056	2	aluminum	
	ISY-100-27058	2	nylon	
	ISY-100-27066	2	aluminum	
	ISY-100-27068	2	nylon	
	ISY-100-27076	2	aluminum	
	ISY-100-27078	2	nylon	

### JIG SET FOR CMM CODE ISY-600



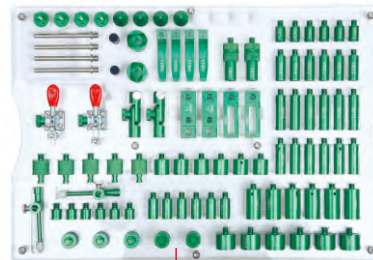





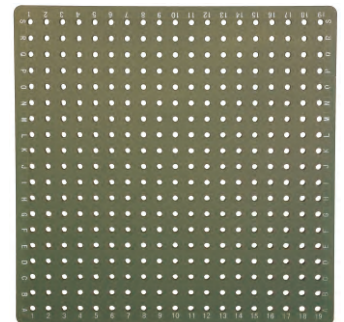

application example









acrylic tray (included)

ISY-600

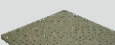

Product	Code	Size (mm)	Quantity
	ISY-600-P1301	Ø13×13	6
	ISY-600-P1302	Ø13×20	6
	ISY-600-P1303	Ø13×26	6
	ISY-600-P1304	Ø13×32	6
	ISY-600-P1305	Ø13×40	6
	ISY-600-P1306	Ø13×45	6
	ISY-600-P1902	Ø20×20	6
	ISY-600-P1905	Ø20×38	6
	ISY-600-P2602	Ø26×20	6
	ISY-600-P1522	—	2
	ISY-600-J1560	—	2
	ISY-600-J1501	48~60	2
 (magnetic top surface)	ISY-600-J2020	Ø20×20	4
	ISY-600-J2021	Ø20×19	2
	ISY-600-J2520	Ø25×20	2
	ISY-600-P2003	M8x1.25	4

Product	Code	Size (mm)	Quantity
	ISY-600-J2060	60×20×10	2
	ISY-600-J2060-2	60×20×10	2
	ISY-600-P1266	12×66	4
	ISY-600-JS201	—	2
	ISY-600-P0684	Ø6×74	4
	ISY-600-P2002	—	4
	ISY-600-P2001	—	4
	ISY-600-400	400×400×18 hole size: M8X1.25	1

## QUICK MEASUREMENT SYSTEM (WITHOUT STITCHING) CODE QMS-A110

**NOTE: NOT SUITABLE FOR SMALL SIZES SUCH AS THREADS, CHAMFERS, ETC**



- One or more workpieces can be measured by one step operation
- Place workpieces at any position
- Focus and measure automatically
- Measurement of 999+dimensions and 200+workpieces
- Suitable for measuring small flat parts

### SPECIFICATION

<b>Optical lens</b>	low-distortion lens, single-field telecentric Ø100mm	
<b>View field range</b>	100×80mm	
<b>Measurement range (X×Y)</b>	98×78mm	
<b>Measurement accuracy *</b>	±3µm	
<b>Repeatability</b>	±1µm	
<b>Max. weight of workpiece</b>	5kg	
<b>Measurement time</b>	<2s	
<b>Measurement data</b>	2D measurement	
<b>Power supply</b>	220V, 50Hz, 600W	
<b>Illumination system</b>	<b>back light</b>	telecentric illuminator, green light
	<b>ring light</b>	4-zone circular white high light circular (directional) low-angle green light (electric)
	<b>coaxial light (optional)</b>	vertical illuminator, white light
<b>Environmental requirement</b>	temperature: 20°C±2°C, relative humidity: 30%~80%, vibration: <0.002g, less than 15Hz	
<b>Dimension (L×W×H)</b>	580×235×790mm	
<b>Weight</b>	40kg	

\* The optimum temperature is 20°C±1°C  
Within 80×64mm, on focal position and environment temperature at 20°C±1°C

### STANDARD DELIVERY

<b>Main unit</b>	1 pc
<b>Computer</b>	1 pc
<b>Software</b>	1 pc

### OPTIONAL ACCESSORY

<b>Coaxial light illumination</b>	<b>QMS-23-A3</b>
<b>Data transmission function of software</b>	<b>QMS-23-D1</b>
<b>CAD import function of software</b>	<b>QMS-23-C1</b>
<b>Foot-switch</b>	<b>QMS-43-FS1</b>
<b>11.6" LCD</b>	<b>QMS-23-B1 (must be installed in factory)</b>



11.6" LCD (optional)

### Software (included)

- Automatically measure widths, holes, rings, angles at the same time, simple and efficient.
- Measuring result can be stored automatically. OK items and NG items can be counted automatically.

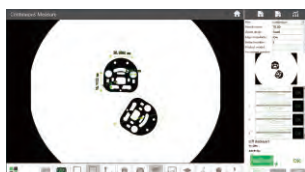
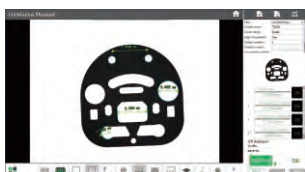

## QUICK MEASUREMENT SYSTEM (WITH STITCHING) CODE QMS-A220

SMALL VIEW FIELD SUITABLE FOR SMALL SIZES SUCH AS THREADS, CHAMFERS, ETC

- One or more workpieces can be measured by one step operation
- Place workpieces at any position
- Focus and measure automatically
- Measurement of 999+dimensions and 200+workpieces
- Suitable for small and medium-size parts with high precision requirements

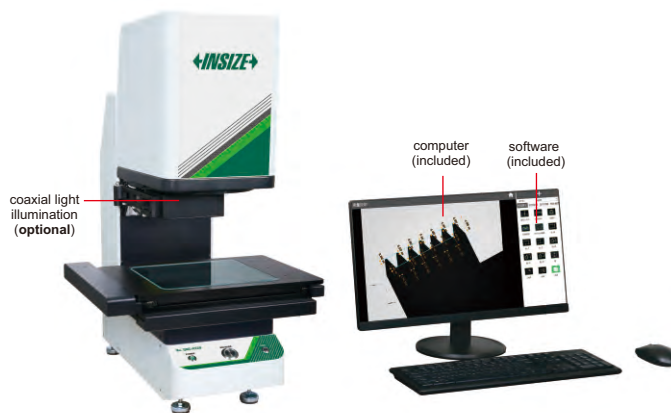

### SPECIFICATION

<b>Optical lens</b>	dual-field dual-telecentric low-distortion lens	
	wide view field: Ø100mm small view field: Ø25mm	
<b>View field range</b>	<b>wide view field</b>	<b>small view field</b>
	93×62mm	20×16mm
<b>Measurement range</b>	200×200mm	130×130mm
<b>Measurement accuracy</b> *	without stitching	±3µm ①
	with stitching	±(5+0.02L)µm ③
<b>Repeatability</b>	without stitching	±1µm
	with stitching	±2µm
<b>Max. weight of workpiece</b>	5kg	
<b>Measurement time</b>	<2s	
<b>Measurement data</b>	2D measurement	
<b>Power supply</b>	220V, 50Hz, 600W	
<b>Illumination system</b>	<b>back light</b>	telecentric illuminator, green light
	<b>ring light</b>	4-zone circular white high light circular (directional) low-angle green light (electric)
	<b>coaxial light (optional)</b>	vertical illuminator, white light
<b>Environmental requirement</b>	temperature: 20°C±2°C, relative humidity: 30%~80%, vibration: <0.002g, less than 15Hz	
<b>Dimension (L×W×H)</b>	532×480×766mm	
<b>Weight</b>	50kg	

\* The optimum temperature is 20°C±1°C

① Within 80×64mm, on focal position and environment temperature at 20°C±1°C

② Within 20×16mm, on focal position and environment temperature at 20°C±1°C

③ Within 180×180mm, on focal position, environment temperature at 20°C±1°C, and workpiece is less than 2kg, L is the travel of stage

④ Within 117×117mm, on focal position, environment temperature at 20°C±1°C, and workpiece is less than 2kg, L is the travel of stage

### OPTIONAL ACCESSORY

<b>Coaxial light illumination</b>	<b>QMS-23-A3</b>
<b>Data transmission function of software</b>	<b>QMS-23-D1</b>
<b>CAD import function of software</b>	<b>QMS-23-C1</b>
<b>Foot-switch</b>	<b>QMS-43-FS1</b>
<b>11.6" LCD</b>	<b>QMS-23-B1 (must be installed in factory)</b>

### STANDARD DELIVERY

<b>Main unit</b>	1 pc
<b>Computer</b>	1 pc
<b>Software</b>	1 pc



11.6" LCD (optional)

### Software (included)

- Automatically measure widths, holes, rings, angles at the same time, simple and efficient.

- Measuring result can be stored automatically. OK items and NG items can be counted automatically.

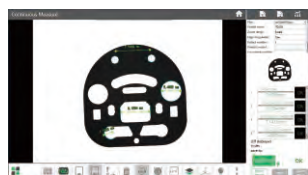

# HORIZONTAL VISION MEASURING SYSTEM CODE ISD-W3150



demo sample (optional)

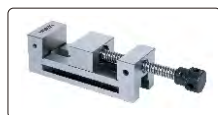

vise (optional)



table (optional)



computer (included)

## SPECIFICATION

Measuring range (X*Z)	300×150mm	
Accuracy	≤(4+L/25)μm L is the measuring length in mm	
Resolution	0.5μm	
Y travel range (focus)	125mm	
Stage	metal stage size	455×126mm
	turning range	±15°
	max. load capacity	30kg
Objective	0.7X~4.5X (zoom)	
Working distance	96mm	
View field (diagonal length)	1.3~8.2mm	
Magnification	34X~213X	
Display	19"	
Camera	1/3" CMOS, 0.8M pixel	
Illumination	surface and contour with adjustable LED	
Operation system	Windows 10	
Drive method	manual	
Power supply	220V, 50Hz	
Dimension (L*W*H)	1164×634×1048mm	
Weight	200kg	

## STANDARD DELIVERY

Main unit (including computer)	1 pc
Software	1 pc
Calibration glass chart	1 pc
Clay	1 pc
Anti-dust cover	1 pc

## OPTIONAL ACCESSORY

0.5X auxiliary objective	code: ISD-W-OB05X working distance: 175mm magnification: 17~106.5X
2X auxiliary objective	code: ISD-W-OB2X working distance: 32mm magnification: 68~426X
Office software	code: 7313-OFFICE
Table	code: ISD-W-TABLE
Vise	code: ISP-A3000-VISE
Demo sample	code: ISP-A3000-DEMO

## MEASURING SOFTWARE (INCLUDED)

The screenshot shows the INSIZE-ME software interface. At the top, it displays the 'XYZ axis' with coordinates: X<sub>0</sub> = 0.0649, Y<sub>0</sub> = -0.4139, and Z<sub>0</sub> = 0.0000. Below this is a table of 'LINE' data with columns for Content, Actual, Nominal, Dev, Light, Line/Obj, and Size. The main area shows a 'measuring graphic' of a circular object with various measurement lines and arcs. A 'measuring results' table is visible on the right. At the bottom, there is a 'measuring objects' list and a 'measuring tools' toolbar. A 'real-time image' of the object is shown in the bottom right corner, with a green 'OK' indicator.

## VISION MEASURING SYSTEMS (MANUAL TYPE)



ISD-V250A

computer is included



lens with coaxial light (optional, must be installed in factory)

### SPECIFICATION

Code	ISD-V150A	ISD-V250A	ISD-V300A
Measuring range (X×Y×Z)	150×100×150mm	250×150×150mm	300×200×150mm
Stage size	354×228mm	450×280mm	500×330mm
Glass stage size	210×160mm	306×196mm	350×250mm
Resolution of X/Y/Z axis	0.5μm		
Accuracy of X/Y axis	≤(3.5+L/100)μm (L is the measuring length in mm)		
Repeatability of X/Y axis	2μm		
Objective	0.7X~4.5X (zoom)		
Working distance	92mm		
Magnification	33X~195X (on 19" monitor)		
Camera	1/3" color CCD, 0.3M pixel		
Illumination	surface and contour with adjustable LED		
Max. height of workpiece	150mm		
Max. weight of workpiece	20kg		
Operation system	Windows 7/8/10		
Drive method	manual		
Power supply	110/220V, 50/60Hz		
Dimension (L×W×H)	560×540×850mm	760×600×900mm	760×600×900mm
Weight	100kg	120kg	140kg

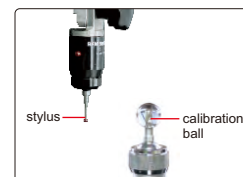

probe (optional), includes Ø2mm and Ø3mm styli, Ø25mm calibration ball, measuring accuracy is 10μm

### STANDARD DELIVERY

Main unit	1 pc
Computer	1 pc
Calibration glass chart	1 pc
Clay	1 pc
Foot switch	1 pc
Anti-dust cover	1 pc

### OPTIONAL ACCESSORY

0.5X auxiliary objective	code: ISD-V-OB05X working distance: 175mm magnification: 16.5~97.5X (on 19" monitor)
2X auxiliary objective	code: ISD-V-OB2X working distance: 36mm magnification: 66~390X (on 19" monitor)
Probe	code: ISD-V-PROBE includes Ø2mm and Ø3mm styli, Ø25mm calibration ball
Vision measuring system with coaxial light lens (with computer)	code: ISD-V150ACL, ISD-V250ACL, ISD-V300ACL
Office software	code: 7313-OFFICE

### SOFTWARE (INCLUDED)

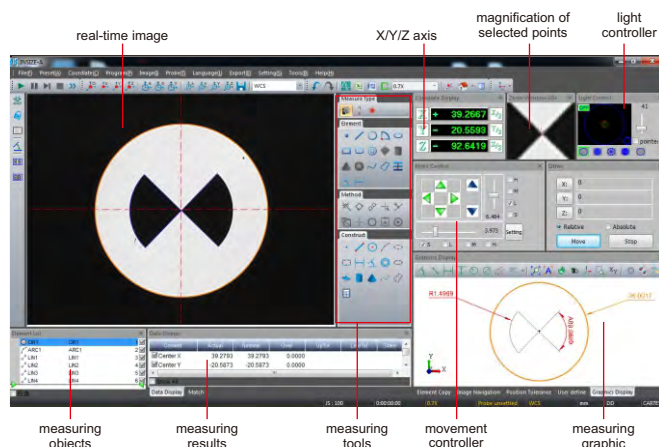



# CNC VISION MEASURING SYSTEMS

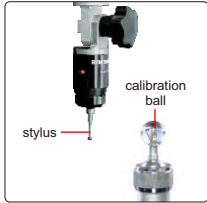

probe (optional), includes Ø2mm and Ø3mm styli, Ø25mm calibration ball, measuring accuracy is 10µm



laser probe (optional) measuring accuracy is 5µm



lens with built-in coaxial light (included)



programmable segmented ring light (included)



ISD-V220CNCA



controller

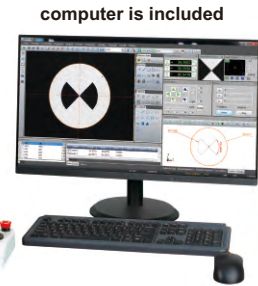

computer is included



software flash disk (included)

- Automatic edge-detection, focus, measuring, contour scanning, calibration, etc.
- Servo motors for X, Y, Z axis
- SPC function for large quantity measurement
- Measuring software is included

## SPECIFICATION

Code (manual zoom lens)	ISD-V220CNCA	ISD-V270CNCA	ISD-V370CNCA
Measuring range (X×Y×Z)	220×120×150mm	270×170×150mm	370×270×150mm
Stage size	450×280mm	500×330mm	606×466mm
Glass stage size	306×196mm	350×250mm	450×350mm
Resolution of X/Y/Z axis	0.5µm		
Accuracy of X/Y axis	≤(2.5+L/100)µm (L is the measuring length in mm)		≤(3.5+L/100)µm (L is the measuring length in mm)
Repeatability of X/Y axis	2µm		
Objective	0.7X~4.5X (zoom)		
Working distance	92mm		
Magnification	33.0X~208.6X (with manual zoom lens, on 24" monitor); 31.9X~188.7X (with motorized zoom lens, on 24" monitor)		
Camera	giga-bit network camera		
Illumination	surface	coaxial light, programmable segmented ring light	
	contour	adjustable LED light	
View field (diagonal length)	1.5~10.8mm		
Max. height of workpiece	150mm		
Max. weight of workpiece	30kg		
Operation system	Windows 7/8/10		
Drive method	automatic		
Power supply	220V, 50/60Hz		
Dimension (L×W×H)	760×600×900mm	760×600×900mm	970×670×940mm
Weight	146kg	168kg	266kg

desk (optional)



## STANDARD DELIVERY

Main unit	1 pc
Software	1 pc
Computer	1 pc
24" display	1 pc
Len with coaxial light	1 pc
Controller	1 pc
Calibration glass chart	1 pc
Laser positioner	1 pc
Clay	1 pc
Anti-dust cover	1 pc

## OPTIONAL ACCESSORY

0.5X auxiliary objective	code: ISD-V-OB05X working distance: 175mm magnification: 16.5~104.3X (with manual zoom lens, on 24" monitor), 16.0~94.4X (with motorized zoom lens, on 24" monitor)
2X auxiliary objective	code: ISD-V-OB2X working distance: 36mm magnification: 66~417.2X (with manual zoom lens, on 24" monitor), 63.8~377.4X (with motorized zoom lens, on 24" monitor)
Probe	code: ISD-V-PROBE includes Ø2mm and Ø3mm styli, Ø25mm calibration ball
Laser probe	code: ISD-V-LASER
Office software	code: 7313-OFFICE
Desk	code: ISD-V-DESK

## SOFTWARE (INCLUDED)

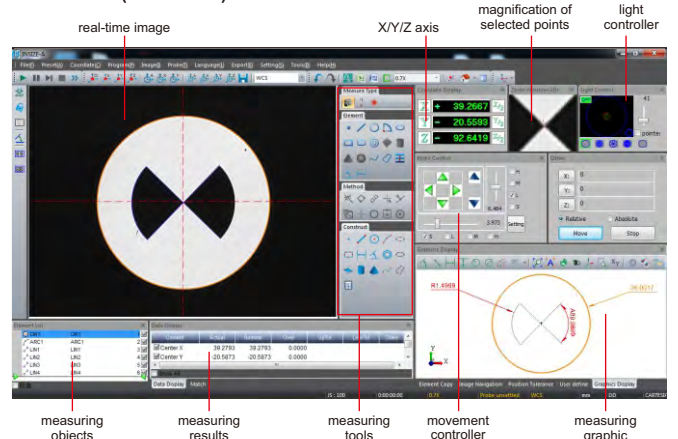

# JIG SET FOR VISION MEASURING SYSTEMS CODE ISY-700

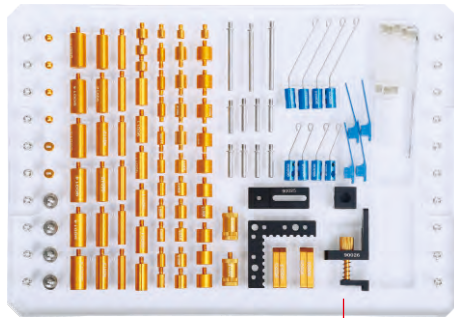



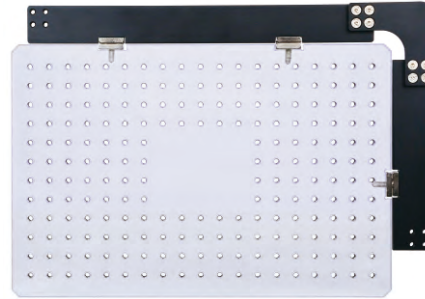





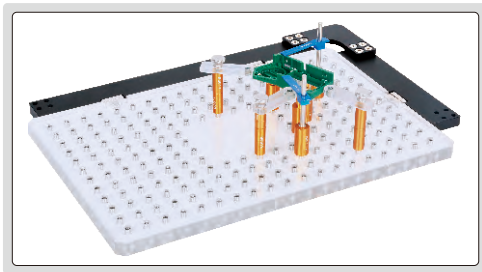

acrylic tray (included)



ISY-700

application example



Product	Code	Size (mm)	Quantity
 clip	ISY-700-90001	7×34	4
 clip	ISY-700-90002	Ø1.5×24	4
	ISY-700-90003	Ø1.5×50	4
 clip stand	ISY-700-90004	Ø4×20	8
	ISY-700-90005	Ø4×46	3
 spherical support head	ISY-700-90006	—	4
 stand	ISY-700-90007	Ø6×10	6
	ISY-700-90008	Ø6×25	6
	ISY-700-90019	Ø6×6	3
 stand	ISY-700-90009	Ø9×7	3
	ISY-700-90010	Ø9×10	6
	ISY-700-90011	Ø9×20	6
	ISY-700-90012	Ø9×25	6
 stand	ISY-700-90013	Ø12×10	6
	ISY-700-90014	Ø12×25	6
 stand for slice parts	ISY-700-90015	Ø6×10	4
	ISY-700-90016	Ø9×10	4
	ISY-700-90017	Ø12×10	4
 stand with fine adjustment	ISY-700-90018	Ø12×20~25	2

Product	Code	Size (mm)	Quantity
 adapter for square support	ISY-700-90020	—	2
 clamping screw	ISY-700-90021	—	4
 L-shaped positioning plate	ISY-700-90022	50×50×6	1
 sliding support plate	ISY-700-90023	30×12×5	4
 square support	ISY-700-90024	20×16×16	1
 base for square support	ISY-700-90025	45×16×6	1
 spring stand	ISY-700-90026	—	1
 acrylic sliding support plate	ISY-700-90028	45×12×5	8
 wrench	ISY-700-90029	M3	1
 acrylic base plate	ISY-700-90030	300×200×12 hole size: M4×0.7	1



## TOOLMAKER MICROSCOPE CODE ISD-VMM215

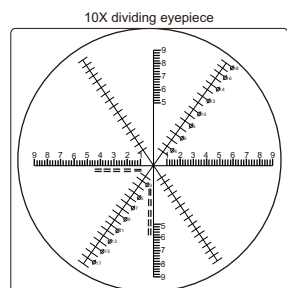

the horizontal and vertical scale lines are used for length measurement, the graduation is 0.2mm. The two diagonal scale lines are used for diameter measurement, the graduation is 1mm (when using 1X objective)



Y-axis reset switch



laser positioning switch

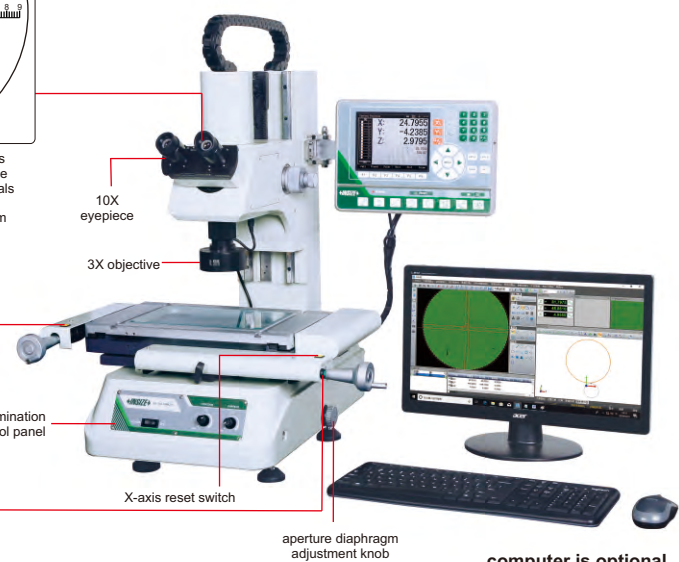

computer is optional

### SPECIFICATION

<b>Code</b>	ISD-VMM215 (binocular)
<b>X/Y axis travel</b>	200×100mm
<b>Z axis travel</b>	150mm
<b>Metal stage size</b>	404×228mm
<b>Glass stage size</b>	260×160mm
<b>Resolution of X/Y/Z axis</b>	0.5μm
<b>Accuracy of X/Y axis</b>	≤(3.5+L/100)μm (L is the measuring length in mm)
<b>Repeatability</b>	2μm
<b>Camera</b>	1/3" color CCD, 0.3M pixel
<b>Optical magnification</b>	30X (with 3X objective)
<b>Image magnification</b>	114X (on 19" monitor)
<b>Illumination</b>	surface and contour with adjustable LED
<b>Max. weight of workpiece</b>	25kg
<b>Power supply</b>	100V~240V, 50/60Hz
<b>Operation system</b>	Windows 7/8/10
<b>Drive method</b>	manual
<b>Dimension (L×W×H)</b>	540×667×850mm
<b>Weight</b>	110kg

### DATA PROCESSING UNIT

Output	RS232
	simple measuring tools
	measure coordinate of points
	measure lines
	measure center coordinate, radius of circle with three points
	measure distances between two objects
	measure angles
	set origin of coordinate
	skew and calibrate the workpiece
	measure rectangle (including length, width, perimeter and center coordinate)
	measure thread (including thread diameter, screw pitch, screw angle)
	measure slot (including center coordinate, length, width)

### STANDARD DELIVERY

<b>Main unit</b>	1 pc
<b>Video card with dongle</b>	1 pc
<b>Software disc</b>	1 pc
<b>Calibration glass chart</b>	1 pc
<b>Demo sample</b>	1 pc
<b>Foot switch</b>	1 pc
<b>3X objective</b>	1 pc

### OPTIONAL ACCESSORY

<b>1X objective</b>	ISD-VMM-LENS1X
<b>5X objective</b>	ISD-VMM-LENS5X
<b>10X objective</b>	ISD-VMM-LENS10X
<b>Toolmaker microscopes (with computer)</b>	code: ISD-VMM215A (binocular)

### SOFTWARE (INCLUDED)

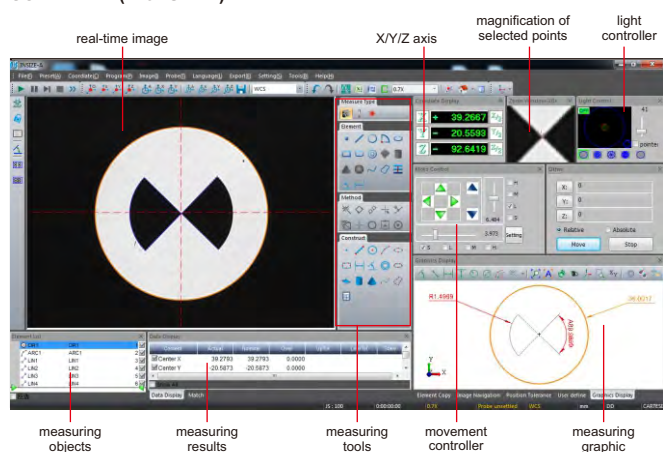

# AUTO FOCUS DIGITAL MICROSCOPE (LARGE VIEW FIELD) CODE 5302-AF105

CAN BE CONNECTED TO PC  
AND TV AT THE SAME TIME

MEASUREMENT

AUTO FOCUS

TAKE PICTURES  
AND VIDEOS



- Auto focus camera
- Take pictures and videos
- Can be connected to TV (HDMI port) and computer (RJ45 port) at the same time
- Built-in measuring software for TV
- Measuring software for computers is included
- Automatic exposure and white balance
- Brightness, contrast ratio, gain are adjustable
- Display cross hair (blue/green/red/yellow/black/brown colors)

## SPECIFICATION

Code	5302-AF105 (standard type)
Pixel	2M
Resolution	1920×1080
Magnification	1.4X~25.8X (on 28" TV)
Sensor	1/2.8" CMOS
Auto focus distance	100mm~∞
Output	HDMI, RJ45
Frame rate	HDMI: 60fps, RJ45: 50fps
Power supply	power adapter
Dimension (L×W×H)	500×280×410mm
Weight	17kg

## STANDARD DELIVERY

Main unit (with stand)	1 pc
LED illumination	1 pc
16G USB flash disk	1 pc
Mouse	1 pc
HDMI cable (for TV)	1 pc
Network cable (for computer)	1 pc
Switch	1 pc
Software for computer	1 pc
Power adapter	2 pcs

## VIEW FIELD

Focus distance	Adjustable magnification (on 28" TV)	View field
100mm	3.9~25.8X	24×14~168×91mm
150mm	2.6~20X	30×17~240×128mm
200mm	2.1~17X	37×20~315×170mm
250mm	1.7~14.7X	42×24~385×210mm
270mm	1.4~14X	43×25~415×225mm

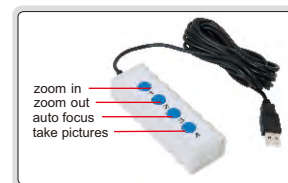

controller (optional, for TV)

## MEASURING ACCURACY

Optical magnification	Measuring accuracy
2X	±0.1mm
4X	±0.1mm
6X	±0.04mm
8X	±0.02mm
14X	±0.02mm

## OPTIONAL ACCESSORY

28" 4K TV	5302-AF-TV28
32" 4K TV	5302-AF-TV32
Computer	5302-AF-COMPUTER
Controller	5302-AF-CONTROLLER

## TV SOFTWARE (INCLUDED)

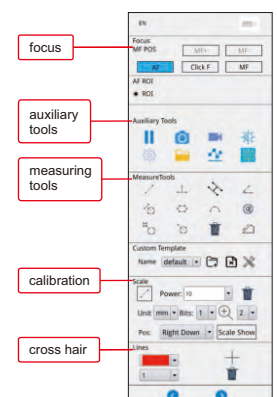

### 3D MOTORIZED ROTATION MICROSCOPE CODE 5301-D400

TAKE PICTURES  
AND VIDEOS

SUITABLE TO CHECK CONVEX  
OBJECTS AND WALL OF HOLE

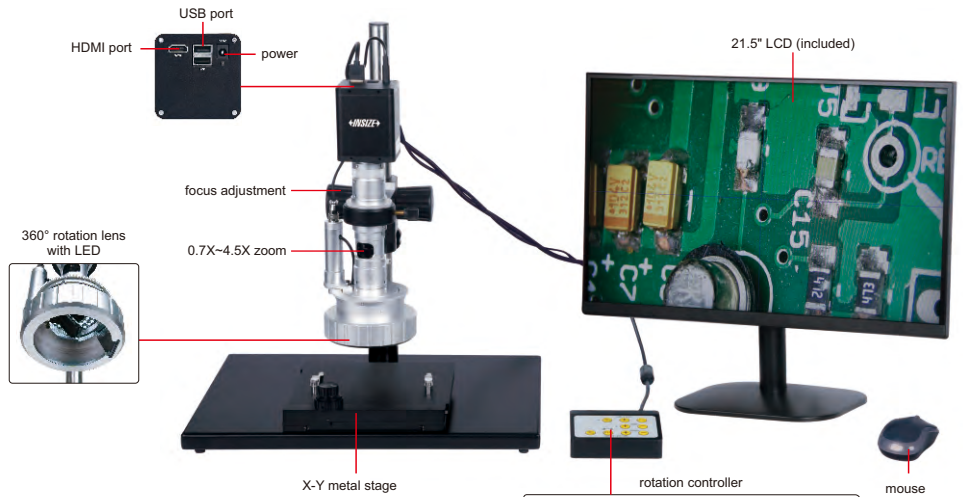
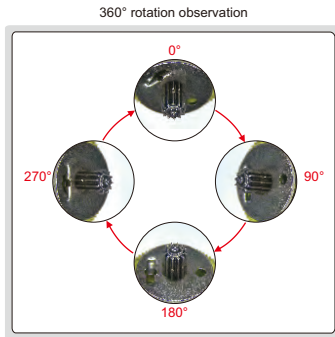

- 1080P high-definition 3D image
- Take pictures and videos, save to USB flash disk
- Automatic white balance and exposure
- Brightness, contrast ratio and gain are adjustable

#### SPECIFICATION

Magnification	15X~100X
View field	4.2×2.7mm~28×18mm
Focus distance	40mm
View angle	45°
Sensor	1/2.8" CMOS
Pixel	2M
Resolution	1920×1080
Frame rate	60fps
Output	HDMI
Rotation speed	2~4RPM
Power supply	110/220V, 50/60Hz
Dimension (L×W×H)	570×300×430mm
Weight	10kg

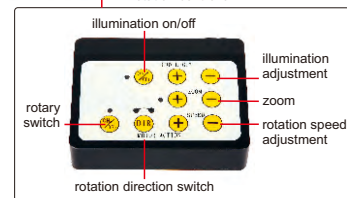

#### STANDARD DELIVERY

Main unit	1 pc
Rotation controller	1 pc
X-Y metal stage	1 pc
16G USB flash disk	1 pc
White/black plate	1 pc
Mouse	1 pc
Power adapter	2 pcs

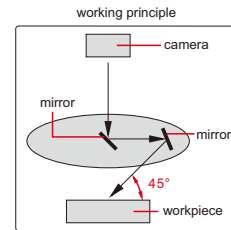

### 3D MANUAL ROTATION MICROSCOPE CODE 5313-S407

SUITABLE TO CHECK CONVEX  
OBJECTS AND WALL OF HOLES

TAKE PICTURES  
AND VIDEOS

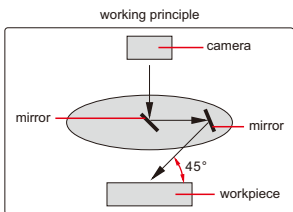

#### SPECIFICATION

Magnification	18X~120X
View field	2.4×1.5mm~16×9mm
Focus distance	20mm
View angle	45°
Sensor	1/2.8" CMOS
Pixel	2M
Resolution	1920×1080
Frame rate	60fps
Output	HDMI
Power supply	220V, 50/60Hz
Dimension (L×W×H)	570×300×430mm
Weight	10kg

#### STANDARD DELIVERY

Main unit	1 pc
X-Y metal stage	1 pc
16G USB flash disk	1 pc
White/black plate	1 pc
Mouse	1 pc
Power adapter	2 pcs

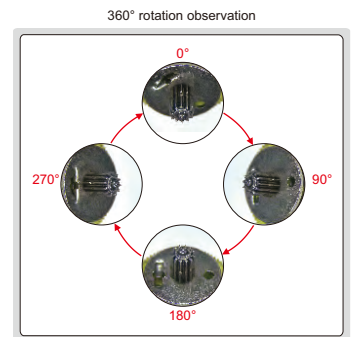

# DIGITAL MEASURING MICROSCOPE (BASIC TYPE) CODE 5318-MD60

MEASUREMENT

TAKE PICTURES

BUILT-IN SOFTWARE WITHOUT COMPUTER



POPULAR MODEL

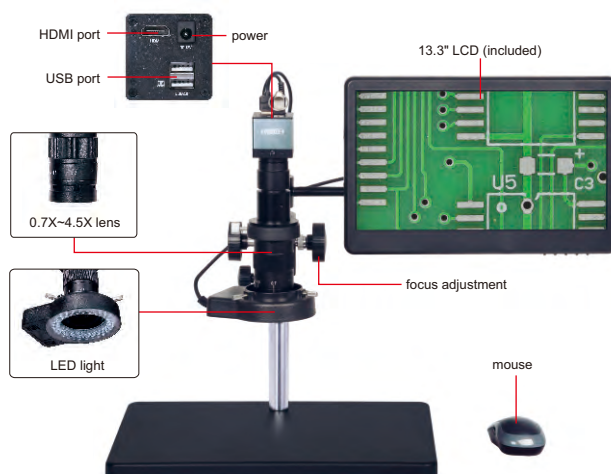

- 1080P high-definition image
- Built-in software without computer, operated by mouse
- Take pictures, save to USB flash disk
- Measurement results can be sent to Excel
- Brightness, contrast ratio, gain are adjustable



white/black plate (included)

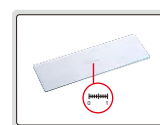

glass calibration rule (graduation 0.1mm, included)



16G USB flash disk (included)

## SPECIFICATION

Magnification	12.5X~80X
Sensor	1/2.8" CMOS
Pixel	2M
Resolution	1920×1080
Frame rate	60fps
Measuring accuracy	±0.02mm
Lines	cross lines, scale lines (number, color and position of lines are adjustable)
Output	HDMI
Power supply	power adapter
Dimension (L×W×H)	380×260×350mm
Weight	4.5kg

## MAGNIFICATION AND VIEW FIELD

Auxiliary objective	Specification	Camera adapter
		0.5X (included)
0.5X (optional)	magnification	6.2~40X
	view field	47×26~7.4×4mm
1X (included)	magnification	12.5~80X
	view field	23.5×13~3.7×2mm
2X (optional)	magnification	25~160X
	view field	11.8×6.5~1.8×1mm

## STANDARD DELIVERY

Main unit	1 pc
0.5X camera adapter	1 pc
1X auxiliary objective	1 pc
White/black plate	1 pc
Glass calibration rule	1 pc
16G USB flash disk	1 pc
Mouse	1 pc
HDMI cable	1 pc
Power adapter	3 pcs

## OPTIONAL ACCESSORY

0.5X auxiliary objective	5318-OB05X
2X auxiliary objective	5318-OB2X

## MEASURING SOFTWARE (INCLUDED)

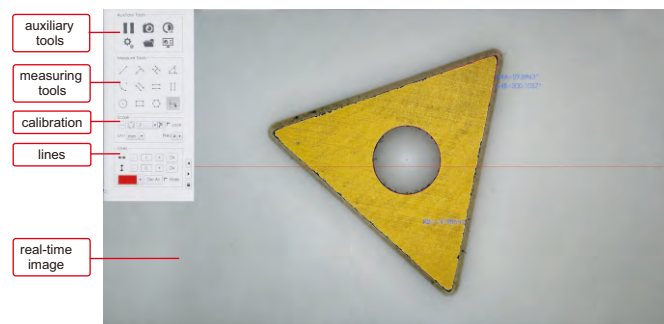

# DIGITAL MEASURING MICROSCOPE

TAKE PICTURES    MEASUREMENT    BUILT-IN SOFTWARE WITHOUT COMPUTER

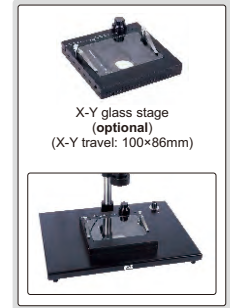
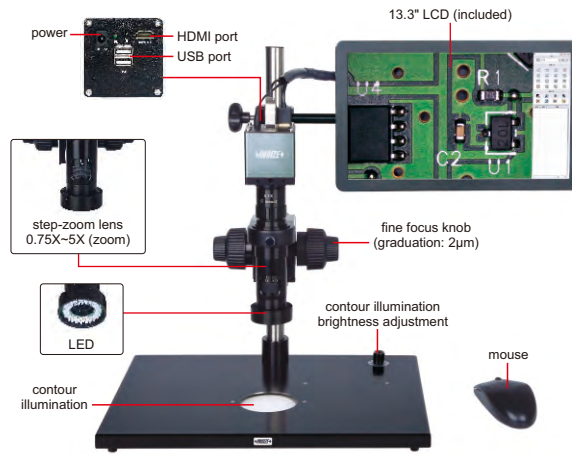

- 1080P high-definition image
- Built-in software without computer, operation by mouse
- Take pictures, saved to USB flash disk
- Measurement results can be output to Excel
- Automatic white balance and exposure
- Brightness, contrast ratio, gain are adjustable

ISM-DL301 (with contour illumination)

## SPECIFICATION

Code	ISM-DL301 (with contour illumination)
Magnification	15X~100X
Sensor	1/2" CMOS
Pixel	2M
Resolution	1920×1080
Frame rate	60fps
Output	HDMI
Power supply	power adapter
Dimension (L×W×H)	570×300×430mm
Weight	6.5kg

## STANDARD DELIVERY

Main unit	1 pc
0.5X camera adapter	1 pc
1X auxiliary objective	1 pc
Calibration plate	1 pc
16G USB flash disk	1 pc
White/black plate	1 pc
Mouse	1 pc
HDMI cable	1 pc
Power adapter	3 pcs

## OPTIONAL ACCESSORY

1X camera adapter	ISM-DL-CA1X
2X auxiliary objective	ISM-DL-OB2X
X-Y glass stage (travel: 74×60mm)	ISM-DL-STAGE
X-Y metal stage	ISM-DL-STAGE1
LED light	see details
Auxiliary objective	see details

## MAGNIFICATION, FOCUS DISTANCE AND VIEW FIELD

Auxiliary objective	Specification	Camera adapter	
		0.5X (included)	1X (optional)
1X (included)	magnification	15~100X	30~200X
	focus distance	70±2mm	70±2mm
	view field	16×11~2.5×1.6mm	7.8×5.3~1.2×0.8mm
2X (optional)	magnification	30~200X	60~400X
	focus distance	29±2mm	29±2mm
	view field	7.8×5.3~1.2×0.8mm	3.8×2.7~0.6×0.4mm

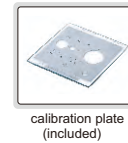

## MAGNIFICATION AND MEASURING ACCURACY

Objective magnification	Image magnification	Measuring accuracy
0.75X	15X	±8μm
1X	20X	±7μm
1.5X	30X	±6μm
2X	40X	±6μm
2.5X	50X	±6μm
3X	60X	±5μm
3.5X	70X	±5μm
4X	80X	±4μm
4.5X	90X	±4μm
5X	100X	±4μm

## SOFTWARE (INCLUDED)

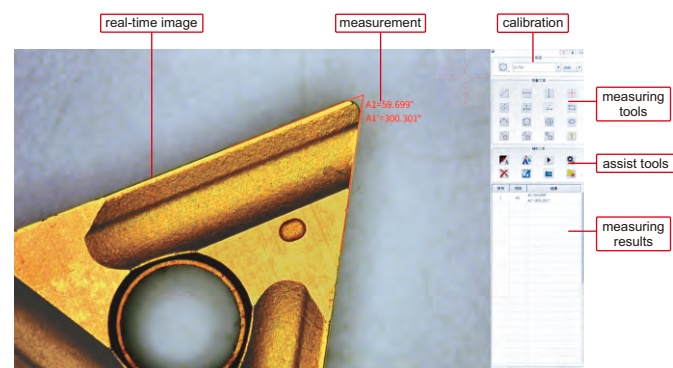

# 4K DIGITAL MEASURING MICROSCOPE CODE 5310-DL401

TAKE  
PICTURES

MEASUREMENT

BUILT-IN SOFTWARE  
WITHOUT COMPUTER

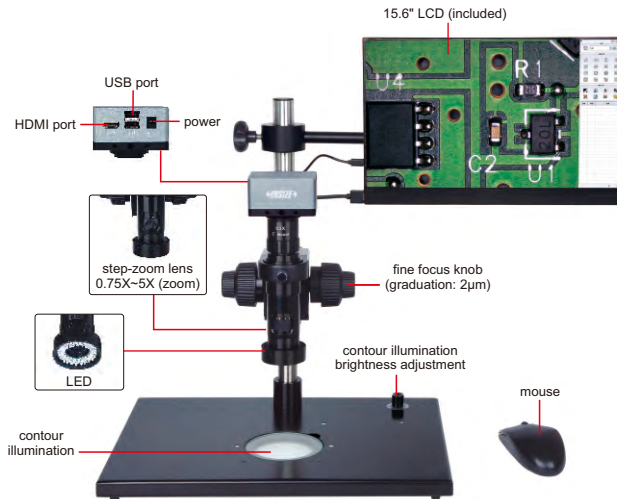

- 4K high-definition image
- Built-in software without computer, operated by mouse
- Take pictures, save to USB flash disk
- Measurement results can be sent to Excel
- Automatic white balance and exposure
- Brightness, contrast ratio, gain are adjustable

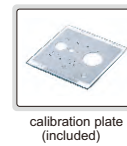
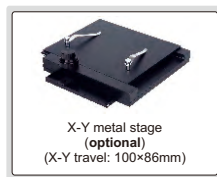
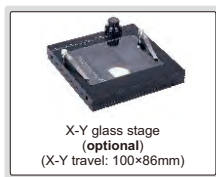

### SPECIFICATION

Magnification	17.6X~120X
Sensor	1/2.3" CMOS
Pixel	8M
Resolution	3840×2160
Frame rate	4K: 30fps, 1080P: 60fps
Output	HDMI
Power supply	power adapter
Dimension (L×W×H)	570×300×430mm
Weight	6.5kg

### MAGNIFICATION, VIEW FIELD AND MEASURING ACCURACY

Objective magnification	Image magnification	View field	Measuring accuracy
0.75X	17.6X	19.5×11.5mm	±5μm
1X	23.7X	14.0×8.0mm	±5μm
1.5X	36.6X	9.0×5.0mm	±5μm
2X	49X	7.0×4.0mm	±5μm
2.5X	62X	5.5×3.0mm	±4μm
3X	73X	4.5×2.5mm	±4μm
3.5X	85X	4.0×2.2mm	±4μm
4X	97X	3.5×2.0mm	±3μm
4.5X	109X	3.0×1.8mm	±3μm
5X	120X	2.7×1.5mm	±3μm

### STANDARD DELIVERY

Main unit	1 pc
0.5X camera adapter	1 pc
1X auxiliary objective	1 pc
Calibration plate	1 pc
16G USB flash disk	1 pc
White/black plate	1 pc
Mouse	1 pc
HDMI cable	1 pc
Power adapter	3 pcs

### OPTIONAL ACCESSORY

1X camera adapter	ISM-DL-CA1X
2X auxiliary objective	ISM-DL-OB2X
X-Y glass stage (travel: 100×86mm)	ISM-DL-STAGE
X-Y metal stage (travel: 100×86mm)	ISM-DL-STAGE1
LED light	see details
Auxiliary objective	see details

### SOFTWARE (INCLUDED)

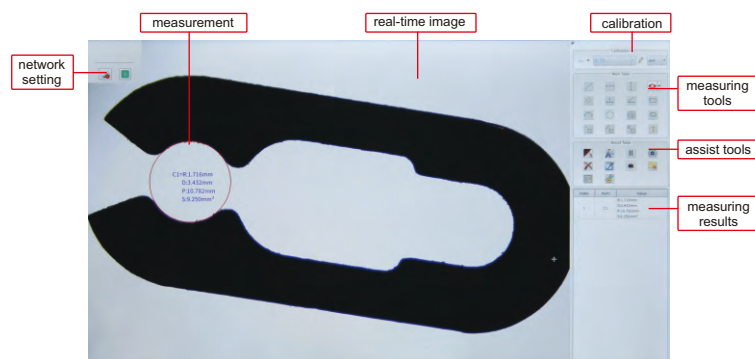



# FLEXIBLE ARM AUTO FOCUS DIGITAL MICROSCOPES

MEASUREMENT

AUTO FOCUS

TAKE PICTURES AND VIDEOS

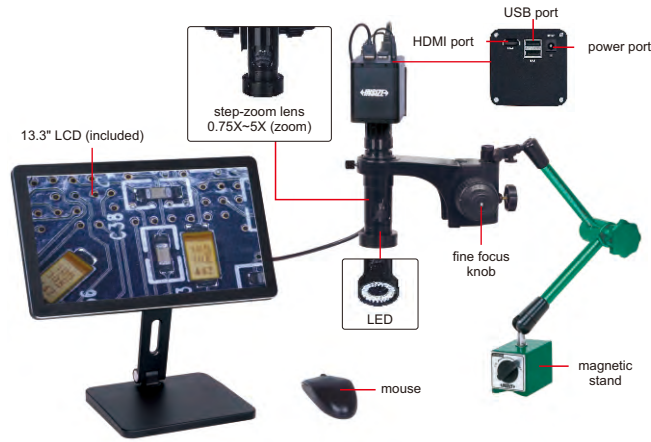

5317-AF109

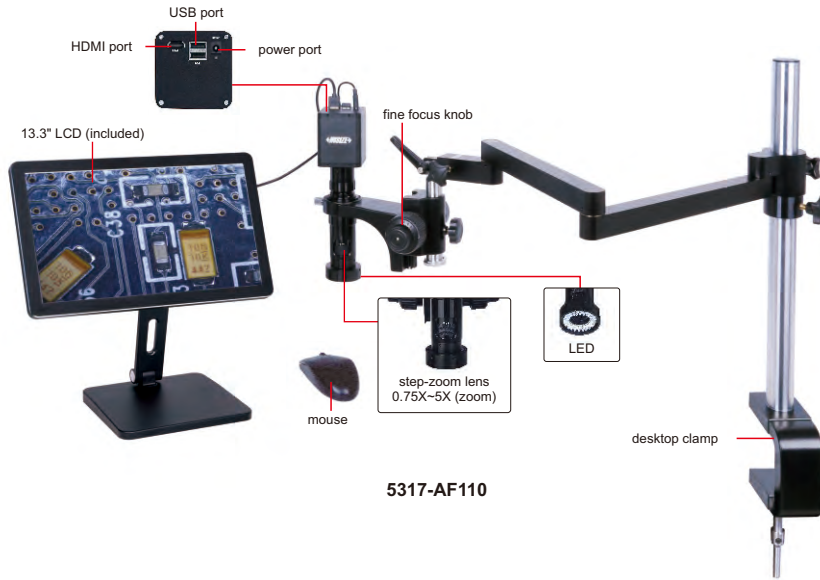

5317-AF110



16G USB flash disk (included)

- 1080P high-definition image
- Auto focus camera
- Take pictures and videos, saved to USB flash disk
- Picture review, picture compare
- Automatic exposure and white balance
- Brightness, contrast ratio, gain are adjustable
- Display cross hair (blue/green/red/yellow/black/brown colors)
- Built-in software without computer, operation by mouse
- Flexible arm

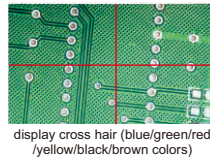

## SPECIFICATION

Code	5317-AF109 (with magnetic stand)	5317-AF110 (with desktop clamp)
Magnification	20X~123X	
Sensor	1/2.8" CMOS	
Pixel	2M	
Resolution	1920×1080	
Frame rate	60fps	
Power supply	power adapter	
Dimension (height)	480mm	600mm
Weight	5.6kg	8.5kg

## MAGNIFICATION, FOCUS DISTANCE AND VIEW FIELD

Auxiliary objective	Specification	Camera adapter	
		0.5X (included)	1X (optional)
1X (included)	magnification	20~123X	40~246X
	focus distance	48~84mm	48~84mm
	view field	13×7~2.2×1mm	6.3×3.5~1.1×0.5mm
	measuring accuracy	±0.02mm	±0.02mm
2X (optional)	magnification	40~246X	80~492X
	focus distance	24~42mm	24~42mm
	view field	6.5×3.5~1.1×0.5mm	3.3×1.8~0.6×0.3mm
	measuring accuracy	±0.02mm	±0.02mm

To be continued

Continued from previous page

### AUTO FOCUS DISTANCE

Zoom objective scale	0.75X	1X	1.5X	2X	2.5X	3X	3.5X	4X	4.5X	5X
Auto focus distance	48~84mm	50~78mm	55~73mm	62~71mm	65~70mm	66~70mm	67~70mm	68~70mm	68~70mm	68~70mm

### STANDARD DELIVERY

Main unit	1 pc
0.5X camera adapter	1 pc
1X auxiliary objective	1 pc
Calibration plate	1 pc
16G USB flash disk	1 pc
White/black plate	1 pc
Mouse	1 pc
HDMI cable	1 pc
Power adapter	2 pcs

### OPTIONAL ACCESSORY

1X camera adapter	ISM-DL-CA1X
2X auxiliary objective	ISM-DL-OB2X
Auxiliary objective	see details

### MEASURING SOFTWARE (INCLUDED)

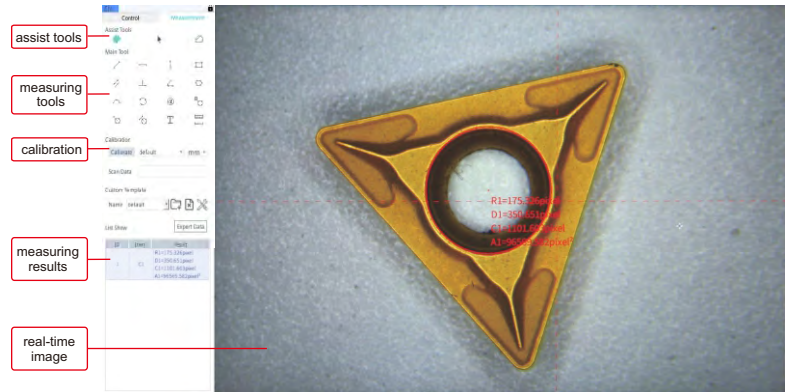

## HORIZONTAL MICROSCOPE CODE 5316-HM810

TAKE  
PICTURES

BUILT-IN SOFTWARE  
WITHOUT COMPUTER

- 1080P high-definition image
- Built-in software without computer, operated by mouse
- Take pictures, save to USB flash disk
- Automatic white balance and exposure
- Brightness, contrast ratio, gain are adjustable
- Display cross hair (blue/green/red/yellow/black/brown colors)

### SPECIFICATION

Magnification	10.5X~62.5X
View field	4.5×2.5~28×12.3mm
Focus distance	115mm
Measuring accuracy	±0.02mm
Sensor	1/2.8" CMOS
Pixel	2M
Resolution	1920×1080
Frame rate	1080P: 60fps/50fps
Output	HDMI
Power supply	110/220V, 50/60Hz
Dimension (L×W×H)	500×200×200mm
Weight	7kg

### STANDARD DELIVERY

Main unit	1 pc
1X camera adapter	1 pc
1X auxiliary adapter	1 pc
Plastic calibration rule	1 pc
16G USB flash disk	1 pc
Mouse	1 pc
LED ring light	1 pc

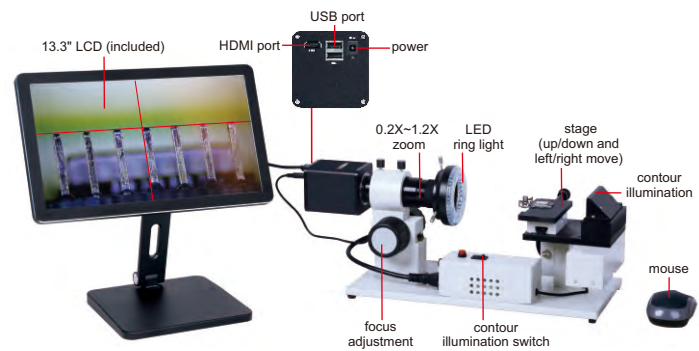

### SOFTWARE (INCLUDED)

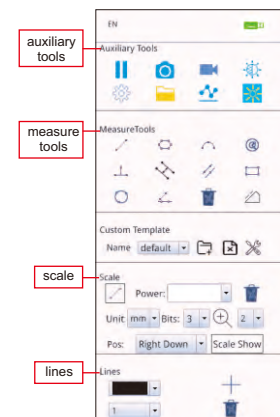

## DIGITAL MEASURING MICROSCOPE (BASIC TYPE) CODE 5307-ID100A

ELECTRONIC MAGNIFICATION  
FEEDBACK LENS

BUILT-IN SOFTWARE  
WITHOUT COMPUTER



- Electronic magnification feedback lens: when the objective lens magnification is changed manually, the software automatically selects the corresponding pre-calibration data and calibration is not needed
- Two methods of LED brightness adjustment, knob adjustment and software adjustment
- Built-in software without computer, operated by mouse
- Take pictures, save to USB flash disk
- Measuring results can be sent to Excel

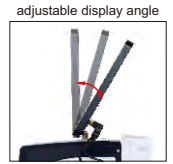

### SPECIFICATION

Sensor	1/2" CMOS
Pixel	2M
Resolution	1920×1080
Magnification	12~77X
Focus distance	65mm
View field	3.2×1.8~20.9×11.7mm
Max workpiece height	60mm
Frame rate	60fps
Output	USB/HDMI
Power supply	power adapter
Dimension (L×W×H)	260×320×500mm
Weight	5.2kg

### STANDARD DELIVERY

Main unit	1 pc
Calibration plate	1 pc
Power adapter	1 pc
Mouse	1 pc
16G USB flash disk	1 pc

### MAGNIFICATION AND MEASURING ACCURACY

Objective magnification	Magnification	Measuring accuracy
0.7X	12X	±9μm
1X	17X	±9μm
1.5X	26X	±8μm
2X	35X	±7μm
2.5X	43X	±7μm
3X	51X	±7μm
3.5X	60X	±6μm
4X	68X	±6μm
4.5X	77X	±5μm

### OPTIONAL ACCESSORY

0.5X auxiliary objective	5307-ID100A-OB05X
0.75X auxiliary objective	5307-ID100A-OB075X
2X auxiliary objective	5307-ID100A-OB2X

## CUTTING TOOLS MICROSCOPE CODE ISM-CT820

TAKE PICTURES  
AND VIDEOS

SPLIT SCREEN  
DESIGN

BUILT-IN SOFTWARE  
WITHOUT COMPUTER

- Split screen design, zoom in and out independently
- One mouse can operate two cameras
- Display cross hairs
- Brightness, contrast ratio, white balance are adjustable
- Basic measuring tools including point to point, point to line, line to line, angle, three-point circle, etc.

### SPECIFICATION

Cutting tools range	Ø4~12mm, length 30-75mm
Lens	step-zoom lens
Output	HDMI
Resolution	1920×1080
Frame rate	60fps
Focus distance	85mm
View field	2×3.5~13.2×23.9mm
Magnification	20-132X
Power supply	AC 100-240V
Dimension (L×W×H)	450×300×700mm
Weight	20kg

### STANDARD DELIVERY

Main unit	1 pc
Display	1 pc
32G USB flash disk	1 pc
Mouse	1 pc
HDMI cable	1 pc
Glass calibration plate	1 pc
Anti-dust cover	1 pc

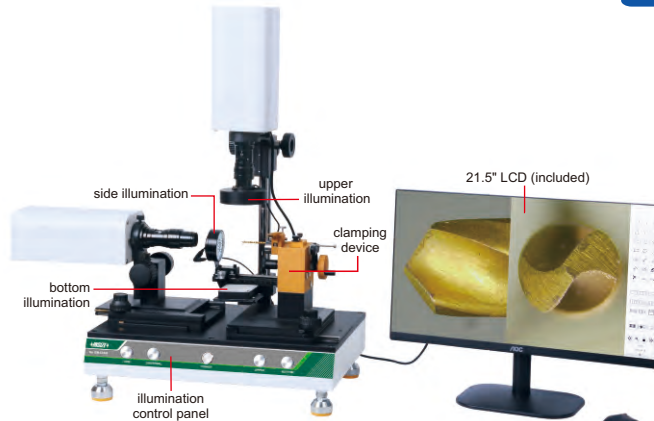

display cross hairs separately (movable)

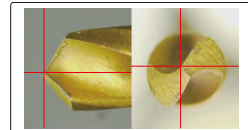

glass calibration plate (included)



screen display

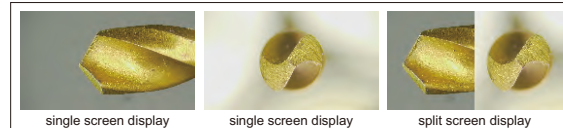

### SOFTWARE (INCLUDED)

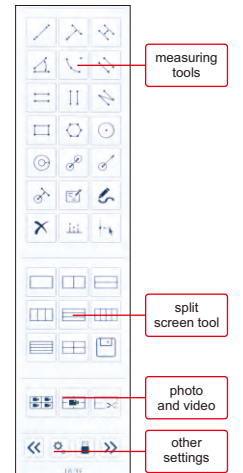

# AUTO FOCUS DIGITAL MICROSCOPE (PROFESSIONAL TYPE) CODE 5319-AF290

- MOTORIZED ZOOM
- MOTORIZED LIGHT CONTROL
- NO CALIBRATION AFTER ZOOM
- AUTO FOCUS
- TAKE PICTURES AND VIDEOS
- MEASUREMENT



calibration plate (included)



16G USB flash disk (included)

- Auto focus camera
- Take pictures and videos
- Built-in measuring software
- Automatic exposure and white balance
- Brightness, contrast ratio, gain are adjustable
- Display actual magnification
- Digital magnification
- Shortcut keyboard operation
- Display cross hair and gridline (blue/green/red/yellow/black/white colors)

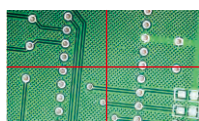

display cross hair and gridline (blue/green/red/yellow/black/white colors)

### Shortcut keyboard function

- Take picture: take a picture and save it
- Video: record a video
- Freeze: the image can be frozen
- Manual focus-: reduce the manual focus value
- Manual focus+: increase the manual focus value
- Zoom+: increase the magnification
- Zoom-: reduce the magnification
- AF/MF: switch to auto focus or manual focus
- FBL: center the camera motor
- Mirror: image horizontal flipover
- Flip: image vertical flipover
- Focus: achieve one-key focus
- Zoom 1, 2, 3, 4: save the current magnification
- Brightness+: increase the brightness of the light
- Brightness-: reduce the brightness of the light



shortcut keyboard (included)

### SPECIFICATION

Magnification	27.4X~163X
Sensor	1/2.8" CMOS
Pixel	2M
Measuring accuracy	±0.02mm
Resolution	1920×1080
Frame rate	50/60fps
Output	HDMI
Power supply	power adapter
Dimension (L×W×H)	600×280×390mm
Weight	6.5kg

### STANDARD DELIVERY

Main unit (with stand)	1 pc
21.5" LCD	1 pc
16G USB flash disk	1 pc
Mouse	1 pc
HDMI cable	1 pc
Calibration plate	1 pc
White/black plate	1 pc
Shortcut keyboard	1 pc
Power adapter	2 pcs

### SOFTWARE (INCLUDED)

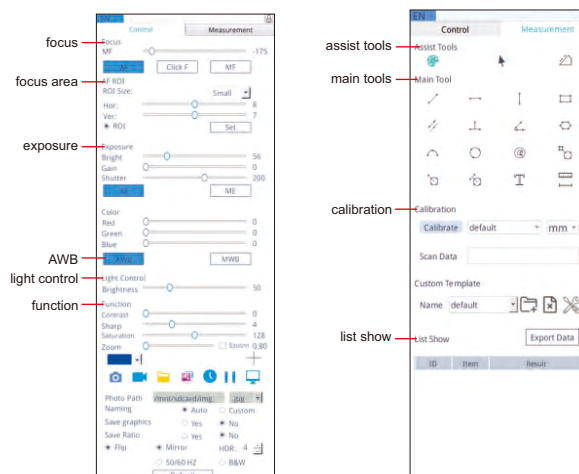

### FOCUS DISTANCE AND VIEW FIELD

Optical magnification*	0.8X	1X	2X	3X	4X	4.76X
Focus distance	88~133mm	88~133mm	98~123mm	103~115mm	108~111mm	108~111mm
View field (mm)	19.4×11~15.8×8.8	15×8.3~12.7×7.2	7.1×4~6.7×3.8	4.8×2.7~4.5×2.5	3.6×2~3.3×1.8	3×1.7~2.8×1.6

\* The optical zoom lens can be arbitrarily zoomed between 0.8X and 4.76X

# MINI DIGITAL MICROSCOPE (ECONOMIC TYPE) CODE 5311-M710

BUILT-IN LITHIUM BATTERY

TAKE PICTURES AND VIDEOS



8G memory card and holder (included)



infrared ray remote controller (included)

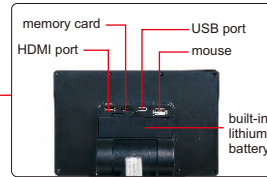

## SPECIFICATION

Display resolution	1024×600
Sensor	1/3" CMOS
Sensor resolution	1280×960
Single pixel size	2μm×2μm
Frame rate	60fps/30fps
Magnification	1X~16X
White balance	auto/manual (10 levels RGB)/calibration
Exposure control	AE lock/exposure compensation (10 levels)
Image control	contrast/saturation/sharpness
Record media	memory card
Output	HDMI
Power supply	built-in lithium battery/power adapter
Dimension (L×W×H)	174×200×350mm
Weight	1.5kg

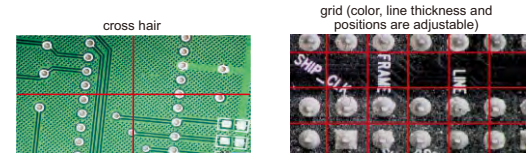

## STANDARD DELIVERY

Main unit	1 pc
USB cable	1 pc
HDMI cable	1 pc
IR remote controller	1 pc
8G memory card and holder	1 pc
Plastic calibration rule	1 pc
Power adapter	1 pc

## SOFTWARE FOR COMPUTER (included)

- Language: Chinese (Simplified), English
- Operation system: Windows 7/8/8.1/10 (64bit)
- Port: USB2.0 or above
- Measuring accuracy: 0.02mm

- |                        |                              |                            |   |
|------------------------|------------------------------|----------------------------|---|
| point counting         | center distance of 2 circles | straight line length       | point-line distance                           |
| continuous line length | radius of a circle           | distance between 2 lines   | distance between parallel lines               |
| area of a rectangle    | cross line                   | radius of a 2-point circle | distance between line and first parallel line |
| area of a polygon      | double cross line            | radius of a 3-point circle | center distance of concentric circle          |
| angle                  | arc                          |                            |   |

## Screen freezing:

full screen

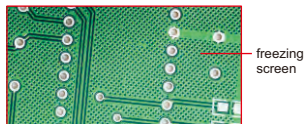

up-down split screen

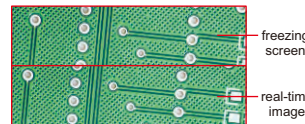

left-right split screen

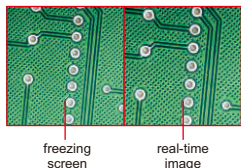

1/4 split screen

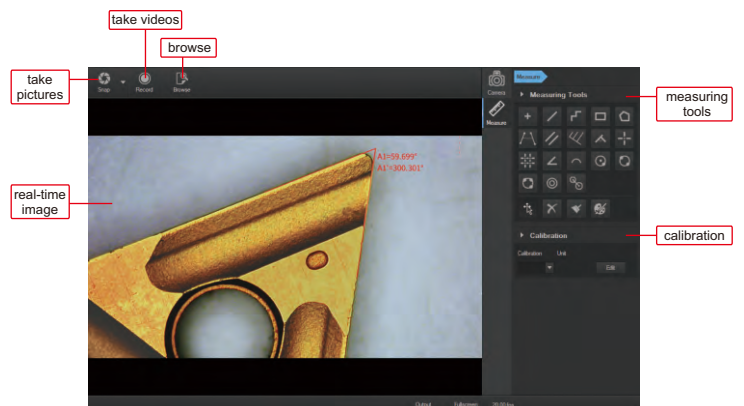
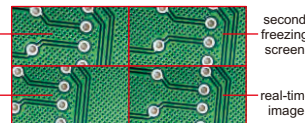

## DIGITAL MEASURING MICROSCOPE

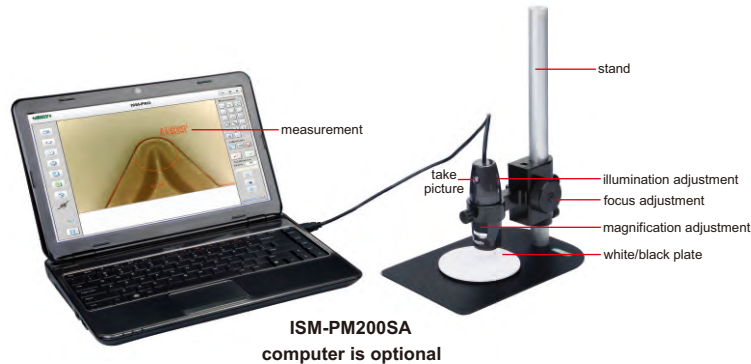

- Can take pictures and videos
- Supplied with software
- Calibration rules (graduation 0.1 and 1mm) are included
- With focus support

### SPECIFICATION

<b>Code</b>	ISM-PM200SA
<b>Magnification</b>	10X~200X
<b>Stand</b>	standard
<b>Pixel</b>	2M (resolution: 1600×1200)
<b>Illumination</b>	built-in adjustable LED
<b>Power supply</b>	USB 2.0 cable (voltage required: 5±0.1V)

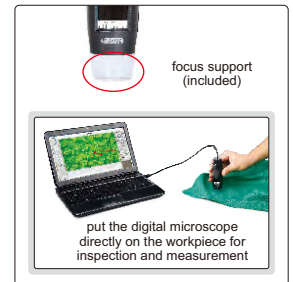

### MAGNIFICATION, FOCUS DISTANCE, VIEW FIELD AND ACCURACY

Magnification	Focus distance	View field (mm)	Accuracy
50X	21mm	8.1×6.4	30μm
100X	13mm	3.9×3.1	15μm
150X	16mm	2.6×2.1	10μm
200X	19mm	1.8×1.5	8μm

### OPTIONAL ACCESSORY

<b>Green filter</b>	ISM-PM-GREEN
<b>Yellow filter</b>	ISM-PM-YELLOW
<b>Blue filter</b>	ISM-PM-BLUE

### SOFTWARE

- **Language:** English, Japanese, Korean, German, Turkey, Portuguese, Chinese
- **Operation system:** Windows 7/8/XP/Vista
- **Measurement tools:**

- measure length of line or distance between two points
- measure distance between point and line
- measure distance between two parallel lines
- measure length of continuous line
- measure area of rectangle
- measure radius, girth and area of circle
- measure radius, length and angle of arc
- measure distance between two circles
- measure angle with three points
- measure angle with two lines
- add text
- add number with circle

#### ■ Edge detection measurement tools:

- detect line automatically, and calculate length
- detect arc automatically, and calculate radius, angle and arc length
- detect two lines automatically, and calculate angle
- detect circle automatically, and calculate radius, girth and area
- detect two parallel lines automatically, and calculate distance

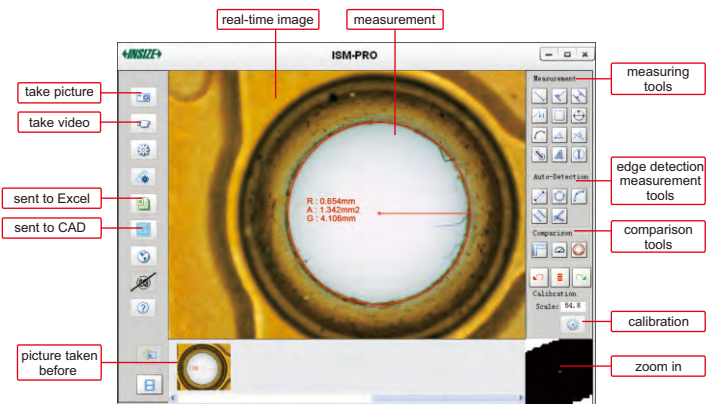

#### ■ Comparison tools:

Create line, angle or circle with desired size, to compare with workpieces.

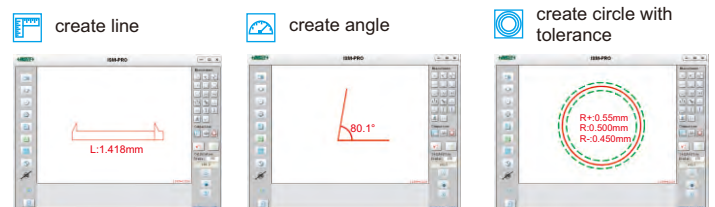

#### ■ Data sent to CAD or Excel:

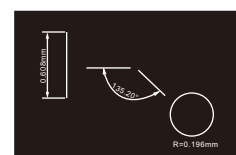

# DIGITAL MEASURING MICROSCOPE CODE ISM-WF200



plastic calibration rule  
(graduation 1mm, included)

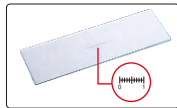

glass calibration rule  
(graduation 0.1mm, included)



software flash disk  
(included)

- Maximum working distance is 5m under WiFi mode
- Can be connected to multiple iPads, Android devices or computers at the same time under WiFi mode
- Take pictures and videos
- Supplied with software

## SPECIFICATION

Magnification	10X~200X
Pixel	1.3M (resolution: 1280x1024)
Illumination	built-in adjustable LED
Power supply	built-in rechargeable battery

## STANDARD DELIVERY

Microscope	1 pc
Focus support ring for 80X/150X	1 pc
Focus support ring for 60X/200X	1 pc
Glass calibration rule (graduation 0.1mm)	1 pc
Plastic calibration rule (graduation 1mm)	1 pc
Software and USB cable	1 pc
AC/DC adapter	1 pc

## OPTIONAL ACCESSORY

Stand	ISM-PM-STAND
Green filter	ISM-PM-GREEN
Yellow filter	ISM-PM-YELLOW
Blue filter	ISM-PM-BLUE



stand (code  
ISM-PM-STAND, optional)



filter (optional)



connected to iPad  
by WiFi

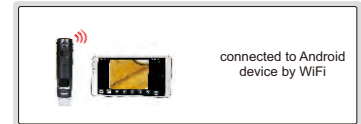

connected to Android  
device by WiFi



connected to computer by WiFi

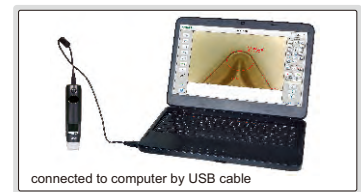

connected to computer by USB cable

## MAGNIFICATION, FOCUS DISTANCE, VIEW FIELD AND ACCURACY

Magnification	Focus distance	View field	Accuracy
50X	21mm	8.1×6.4mm	30μm
100X	13mm	3.9×3.1mm	15μm
150X	16mm	2.6×2.1mm	10μm
200X	19mm	1.8×1.5mm	8μm

### 1 Software ISM-PAD (for iPad by WiFi)

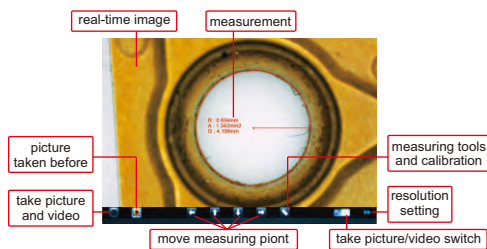

### 2 Software ISM-APK (for Android devices by WiFi)

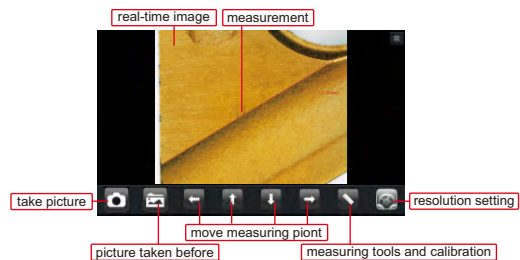

### 3 Software ISM-WF Partner (for computer by WiFi)

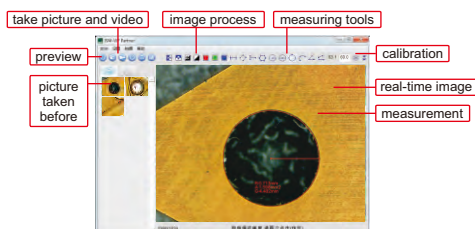

### 4 Software ISM-PRO (for computer by USB cable)

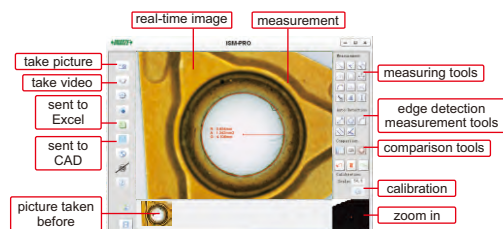

## INDUSTRIAL MICROSCOPES



- Infinite optical system, polarization observation, dark field observation
- Kohler illumination system provides uniform illumination field
- Objective 50X is spring type

### STANDARD DELIVERY

Main unit	1 pc
Anti-dust cover	1 pc

### SPECIFICATION

Code	5101-M500 (bright field objectives)				5101-M500BD (bright & dark field objectives)			
Illumination	6V/30W halogen lamp, brightness is adjustable				12V/50W halogen lamp, brightness is adjustable			
Objective (infinite plan achromatic)	bright field objectives				bright & dark field objectives			
	5X	10X	20X	50X	5X	10X	20X	50X
Working distance	26.1mm	20.2mm	8.80mm	3.68mm	9.70mm	9.30mm	7.23mm	2.50mm
Numerical aperture	0.12	0.25	0.40	0.70	0.12	0.25	0.40	0.70
Magnification	50X~500X							
Eyepiece (wide field)	10X (view field: Ø22mm)							
	double layer							
Stage	size: 160×140mm							
	travel: 35x30mm							
Pupil distance	53~75mm							
Diopter adjustment	±5 diopter (one eyepiece)							
Power supply	220V, 50/60Hz							
Dimension (L×W×H)	415×345×380mm							
Weight	14kg							

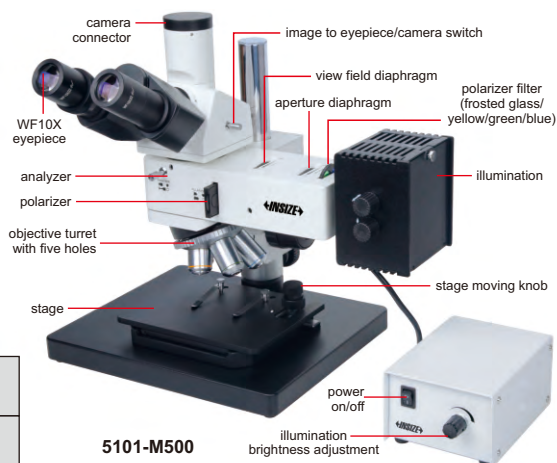

5101-M500

### OPTIONAL ACCESSORY

Bright field objective (for 5101-M500)	PL40X	5101-M-OB40X
	PL60X	5101-M-OB60X
	PL80X	5101-M-OB80X
	PL100X	5101-M-OB100X
Camera adapter *		5101-M-ADAPTER
Bright & dark field objective (for 5101-M500BD)	PL40X	5101-M-BD40X
	PL60X	5101-M-BD60X
	PL80X	5101-M-BD80X
	PL100X	5101-M-BD100X
10X dividing eyepiece (0.1mm/div.)		5101-M-EPD10X
Digital camera		ISM-CM20, ISM-CM63, ISM-ZS70-S

\*Digital camera must be used with camera adapter

## METALLURGICAL MICROSCOPES



- Infinite optical system, polarization observation, dark field observation
- Kohler illumination system provides uniform illumination field
- Objectives 50X, 100X are spring type

### STANDARD DELIVERY

Main unit	1 pc
Polarizer and analyzer	1 pc of each
Anti-dust cover	1 pc

### SPECIFICATION

Code	5103-M1000 (bright field objectives)				5103-M1000BD (bright & dark field objectives)			
Illumination	6V/30W halogen lamp, brightness is adjustable				12V/50W halogen lamp, brightness is adjustable			
Objective (infinite plan achromatic)	bright field objectives				bright & dark field objectives			
	10X	20X	50X	100X	5X	10X	20X	50X
Working distance	20.2mm	8.80mm	3.68mm	0.40mm	9.70mm	9.30mm	7.23mm	2.50mm
Numerical aperture	0.25	0.40	0.70	0.85	0.12	0.25	0.40	0.70
Magnification	100X~1000X				50X~500X			
Eyepiece (wide field)	10X (view field: Ø22mm)							
	double layer							
Stage	size: 242×200mm							
	travel: 30x30mm							
Pupil distance	53~75mm							
Diopter adjustment	±5 diopter (one eyepiece)							
Power supply	220V, 50/60Hz							
Dimension (L×W×H)	614×250×394mm							
Weight	13kg							



5103-M1000

### OPTIONAL ACCESSORY

Bright field objective (for 5103-M1000)	PL5X	5101-M-OB5X
	PL40X	5101-M-OB40X
	PL60X	5101-M-OB60X
	PL80X	5101-M-OB80X
Bright & dark field objective (for 5103-M1000BD)	PL40X	5101-M-BD40X
	PL60X	5101-M-BD60X
	PL80X	5101-M-BD80X
	PL100X	5101-M-BD100X
10X dividing eyepiece (0.1mm/div.)		5103-M-EPD10X
Camera adapter *		5101-M-ADAPTER
Digital camera		ISM-CM63

\*Digital camera must be used with camera adapter



## METALLURGICAL MICROSCOPES (PROFESSIONAL TYPE)

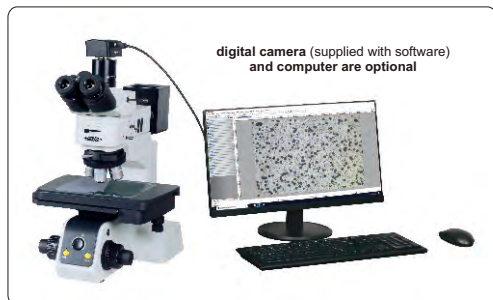

5108-M3000

- Infinite chromatic aberration correction optical system
- Three way observation tube with infinite hinge
- Translucent and reflective frame, front low-hand position coarse and fine coaxial focus adjustment mechanism, with adjustment elastic device to prevent sliding and random upper limit device
- Bright and dark field five-hole converter with DIC slot
- Adopt digital dimming, with light intensity reset and setting function
- With polarizer insert plate and 360° rotating analyzer insert slot

### SPECIFICATION

Code	5108-M3000 (standard type)				5108-M3000H (high-definition type)			
Eyepiece	high eye point large field SWH10X-H (view field: Ø25mm, adjustable visibility)							
Objective (infinite long working distance bright and dark field semi achromatic)	5X	10X	20X	50X	5X	10X	20X	50X
Working distance	15mm	8.4mm	10.3mm	3.0mm	20mm	11mm	3.0mm	1.0mm
Numerical aperture	0.15	0.30	0.40	0.75	0.15	0.30	0.45	0.80
Optical magnification	50X~500X (up to 1000X with optional 100X objective)							
Digital magnification	170X~1700X (on 21.5" monitor), up to 3400X with optional 100X objective							
Stage	double layer size: 310×240mm travel: 150×100mm							
Condenser	roll-out achromatic condenser (numerical aperture 0.9)							
Illumination	5W LED, transmitted and reflected							
Observation tube	inverse image, distance adjustment: 50~76mm, two grade spectral ratio binocular: trinocular=100:0							
Diopter adjustment	±5 diopter (two eyepieces)							
Power supply	AC 100-240V							
Dimension (L×W×H)	310×600×500mm							
Weight	27kg							

### OPTIONAL ACCESSORY

Camera and software	ISM-CM63
Glass calibration rule	ISM-MAS-SCALE
Computer	5108-M-COMPUTER
2.5X infinite long working distance bright field semi achromatic objective	5108-M-OB2D5X
100X infinite long working distance bright and dark field semi achromatic objective	5108-M-BD100X
50X infinite long working distance bright and dark field achromatic objective	5108-M-APO50X
100X infinite long working distance bright and dark field achromatic objective	5108-M-APO100X
Differential interference module (DIC)	5108-M-DIC

### STANDARD DELIVERY

Main unit	1 pc
Anti-dust cover	1 pc
0.65X camera adapter (adjustable focus)	1 pc
Polarizer and analyzer	1 pc of each

## METALLURGICAL MICROSCOPES



VIDEO

- Infinite optical system, observation in reflected or transmitted illumination, polarizing observation and dark field observation
- Kohler illumination system provides uniform illumination field
- Objectives 40X, 60X are spring type



blue filter (included)



frosted glass filter (included)

### STANDARD DELIVERY

Main unit	1 pc
Anti-dust cover	1 pc
Filter (blue/frosted glass)	1 pc of each

### SPECIFICATION

Code	5102-M600 (bright field objectives)	5102-M600BD (bright & dark field objectives)
Illumination	6V/30W (transmitted), 6V/30W (reflected)	12V/30W (transmitted), 12V/50W (reflected)
Objective (infinite plan achromatic)	bright field objectives	bright & dark field objectives
	5X 10X 40X 60X	5X 10X 20X 40X
Working distance	26.1mm 20.2mm 3.98mm 3.18mm	9.70mm 9.30mm 7.20mm 3.00mm
Numerical aperture	0.12 0.25 0.60 0.70	0.12 0.25 0.40 0.70
Magnification	50X~600X	50X~400X
Eyepiece (wide field)	10X (view field: Ø22mm)	
Stage	double layer size: 210×140mm travel: 75x50mm	
Pupil distance	53~75mm	
Diopter adjustment	±5 diopter (one eyepiece)	
Power supply	220V, 50/60Hz	
Dimension (L×W×H)	456×260×498mm	
Weight	11kg	

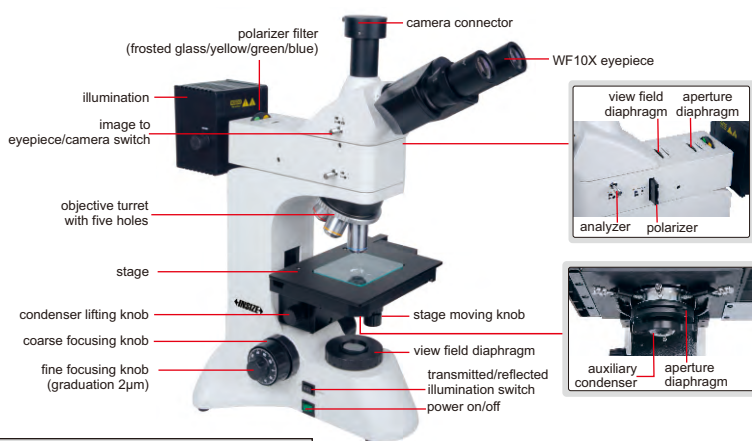

5102-M600

### OPTIONAL ACCESSORY

Bright field objective (for 5102-M600)	PL20X	5101-M-OB20X
	PL50X	5101-M-OB50X
	PL80X	5101-M-OB80X
	PL100X	5101-M-OB100X
Camera adapter*		5101-M-ADAPTER
Bright & dark field objective (for 5102-M600BD)	PL50X	5101-M-BD50X
	PL60X	5101-M-BD60X
	PL80X	5101-M-BD80X
	PL100X	5101-M-BD100X
10X dividing eyepiece (0.1mm/div.)		5101-M-EPD10X
Digital camera		ISM-CM20, ISM-CM63, ISM-ZS70-S

\*Digital camera must be used with camera adapter

## ZOOM STEREO MICROSCOPE (PROFESSIONAL TYPE) CODE 5107-S70T



VIDEO

- Greenough optical system, clear observation, real color
- High working distance is convenient for operation
- Excellent flat image and large depth of field, make observation comfortable
- 6.7:1 large zoom ratio, allow quick observation adjustment

### SPECIFICATION

Optical tube	trinocular
Eyepiece (wide field)	10X (view field: Ø22mm)
Objective	0.67X~4.5X (zoom)
Observation tube	45° trinocular tube inclination angle, built-in 0.5X adapter
Zoom ratio	6.7:1
Pupil distance	50~75mm
Diopter adjustment	-8~+5 diopter (both eyepieces)
Working distance of objective	110mm
Max. workpiece height	106mm
Illumination	adjustable LED light
Power supply	110/220V
Dimension (L×W×H)	330×300×368mm
Weight	3.5kg



white/black plate (included)



frosted glass filter (included)

### STANDARD DELIVERY

Main unit	1 pc
10X eyepiece	2 pcs
Ø100mm glass plate	1 pc
Ø100mm white/black plate	1 pc
Anti-dust cover	1 pc

### OPTIONAL ACCESSORY

Auxiliary objective	0.5X	5107-S70T-OB05X
	1.5X	5107-S70T-OB15X
	2X	5107-S70T-OB20X
Eyepiece	15X (view field: Ø16mm)	5107-S70T-EP15X
	20X (view field: Ø12.5mm)	5107-S70T-EP20X
LED ring light		ISM-ZS-RL
Digital camera		ISM-CM20, ISM-CM63, ISM-ZS70-S



LED ring light (optional)

## PARALLEL LIGHT STEREO MICROSCOPE CODE ISM-ZS200

PARALLEL LIGHT PATH: REDUCE FATIGUE  
ACCESSORIES CAN BE ADDED INTO LIGHT PATH



- Infinity parallel optical system and 20° inclined optical tube reduce fatigue
- Coaxial illumination is optional for deep holes which cannot be observed by ring light
- Aperture diaphragm is optional for large depth for field and high quality image

### SPECIFICATION

Optical tube	binocular (20° inclined)
Eyeiece (wide field)	10X (view field: Ø22mm)
Objective	0.8X~8X (zoom)
Zoom ratio	1:10
Pupil distance	55~75mm
Diopter adjustment	±5 diopter (both eyepieces)
Working distance of objective	78mm
Max. workpiece height	72mm
Illumination	adjustable reflected and transmitted LED light
Power supply	110/220V, 50/60HZ
Dimension (L×W×H)	240×280×440mm
Weight	4.3kg

### STANDARD DELIVERY

Main unit	1 pc
WF 10X eyepiece	2 pcs
Ø100mm glass plate	1 pc
Ø100mm white/black plate	1 pc
Anti-dust cover	1 pc



### OPTIONAL ACCESSORY

Objective	0.5X achromatic objective (focus distance: 186mm)	ISM-ZS200-OB05X*
	2X plan achromatic objective (focus distance: 32.5mm)	ISM-ZS200-OB2X
	0.5X plan apochromatic objective (focus distance: 126mm)	ISM-ZS200-APO05X*
Eyepiece	WF15X (view field: Ø16mm)	ISM-ZS200-EP15X
	WF20X (view field: Ø12mm)	ISM-ZS200-EP20X
	WF30X (view field: Ø20mm)	ISM-ZS200-EP30X
Sleeve for auxiliary objective		ISM-ZS200-ADAPTER
Iris diaphragm		ISM-ZS200-IRD
Optical path splitter		ISM-ZS200-OBS
Coaxial illumination		ISM-ZS200-COAXIAL
Digital camera**		ISM-CM20, ISM-CM63

\* 0.5X auxiliary objective must be used with ISM-ZS200-ADAPTER

\*\* Digital camera must be used with optical path splitter

## ZOOM STEREO MICROSCOPES (ADVANCED TYPE)

LARGE ZOOM  
RATIO



### SPECIFICATION

Code	ISM-ZS100	ISM-ZS100T
Optical tube	binocular	trinocular
Eyeiece (wide field)	10X (view field: Ø23mm)	
Objective	0.6X~5X (zoom)	
Zoom ratio	1:8.3	
Pupil distance	55~75mm	
Diopter adjustment	±5 diopter (two eyepieces)	
Working distance of objective	115mm	
Max. workpiece height	75mm	
Illumination	adjustable reflected and transmitted LED light	
Power supply	110/220V, 50/60HZ	
Dimension (L×W×H)	260×310×490mm	
Weight	4.9kg	

### STANDARD DELIVERY

Main unit	1 pc
Digital camera adapter 0.55X for ISM-ZS100T	1 pc
WF10X eyepiece	2 pcs
Ø100mm glass plate	1 pc
Ø100mm white/black plate	1 pc
Anti-dust cover	1 pc

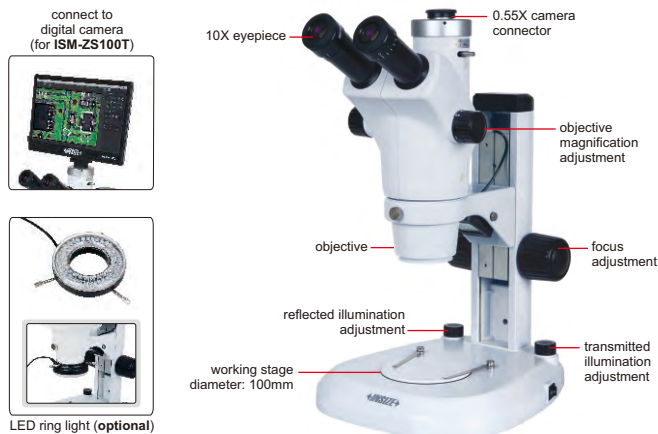

ISM-ZS100T

### OPTIONAL ACCESSORY

Auxiliary objective	0.5X (focus distance: 220mm)	ISM-ZS100-OB05X*
	0.7X (focus distance: 125mm)	ISM-ZS100-OB07X
	2X (focus distance: 45mm)	ISM-ZS100-OB2X
Eyepiece	WF15X (view field: Ø16mm)	ISM-ZS100-EP15X
	WF20X (view field: Ø12mm)	ISM-ZS100-EP20X
	WF30X (view field: Ø8mm)	ISM-ZS100-EP30X
Sleeve for auxiliary objective		ISM-ZS200-ADAPTER
LED ring light		ISM-ZSRL
Digital camera adapter 1X for ISM-ZS100T		ISM-ZS100-DA
Digital camera for ISM-ZS100T		ISM-CM20, ISM-CM63, ISM-ZS70-S

\* 0.5X auxiliary objective must be used with ISM-ZS200-ADAPTER

## ZOOM STEREO MICROSCOPES (STANDARD TYPE)



### SPECIFICATION

Code	ISM-ZS50	ISM-ZS50T
Optical tube	binocular	trinocular
Eyeiece (wide field)	10X (view field: Ø22mm)	
Objective	0.8X~5X (zoom)	
Zoom ratio	1:6.3	
Pupil distance	55-75mm (adjustable)	
Diopter adjustment	±5 diopter (two eyepieces)	
Working distance of objective	115mm	
Max. workpiece height	75mm	
Illumination	adjustable reflected and transmitted LED light	
Power supply	110/220V, 50/60Hz	
Dimension (L×W×H)	290x260x480mm	
Weight	4.9kg	

### STANDARD DELIVERY

Main unit	1 pc
WF10X eyepiece	2 pcs
Ø100mm glass plate	1 pc
Ø100mm white/black plate	1 pc
Anti-dust cover	1 pc



LED ring light (optional)



ISM-ZS50

### OPTIONAL ACCESSORY

Auxiliary objective	0.5X	ISM-ZS50-OB05X*
	2X	ISM-ZS50-OB2X
Eyepiece	10X dividing eyepiece (graduation 0.1mm/div.)	ISM-ZS50-EPD10X
	WF15X (view field: Ø16mm)	ISM-ZS50-EP15X
	WF20X (view field: Ø12mm)	ISM-ZS50-EP20X
LED ring light		ISM-ZS-RL
Sleeve for auxiliary objective		ISM-ZS200-ADAPTER
Digital camera for ISM-ZS50T		ISM-CM20, ISM-CM63, ISM-ZS70-S
Camera adapter 0.5X for ISM-ZS50T**		ISM-MAS-ADAPTER

\* 0.5X auxiliary objective must be used with ISM-ZS200-ADAPTER

\*\* Digital camera must be used with camera adapter 0.5X

## ZOOM STEREO MICROSCOPES (WITH UNIVERSAL STAND)



### SPECIFICATION

Code	5106-M50	5106-M50T
Optical tube	binocular	trinocular
Eyeiece (wide field)	10X (view field: Ø22mm)	
Objective	0.8X~5X (zoom)	
Zoom ratio	1:6.3	
Pupil distance	55~75mm	
Diopter adjustment	±5 diopter (two eyepieces)	
Working distance of objective	115mm	
Max. workpiece height	300mm	
Illumination	adjustable reflected LED ring light	
Power supply	power adapter	
Dimension (L×W×H)	790×230×430mm	
Weight	20kg	

### STANDARD DELIVERY

Main unit (with stand)	1 pc
WF 10X eyepiece	2 pcs
LED ring light	1 pc
Anti-dust cover	1 pc

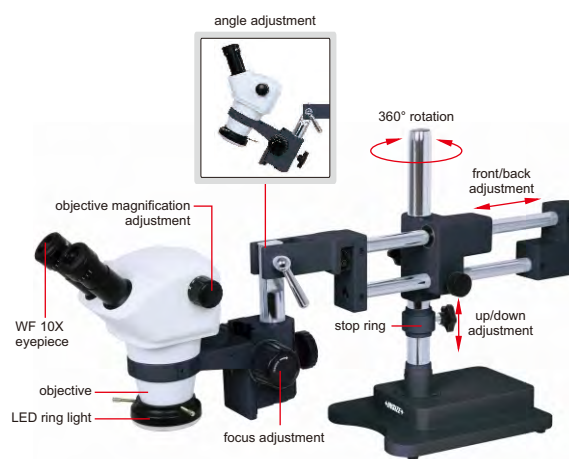

5106-M50

### OPTIONAL ACCESSORY

Auxiliary objective	0.5X	ISM-ZS50-OB05X*
	2X	ISM-ZS50-OB2X
Eyepiece	10X dividing eyepiece (0.1mm/div.)	ISM-ZS50-EPD10X
	WF15X (view field: Ø16mm)	ISM-ZS50-EP15X
	WF20X (view field: Ø12mm)	ISM-ZS50-EP20X
Sleeve for auxiliary objective		ISM-ZS30-ADAPTER
Digital camera for 5106-M50T		ISM-CM20, ISM-CM63
Camera adapter 0.5X for 5106-M50T**		ISM-MAS-ADAPTER

\* 0.5X auxiliary objective must be used with ISM-ZS30-ADAPTER

\*\* Digital camera must be used with camera adapter 0.5X

## ZOOM STEREO MICROSCOPE (BASIC TYPE) CODE ISM-ZS30

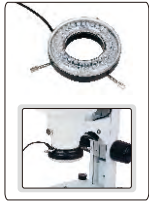

LED ring light (optional)



### SPECIFICATION

Optical tube	binocular
Eyepiece (wide field)	10X (view field: Ø20mm)
Objective	1X~4.5X (zoom)
Zoom ratio	1:4.5
Pupil distance	55~75mm (adjustable)
Diopter adjustment	±5 diopter (two eyepieces)
Working distance of objective	97mm
Max. workpiece height	60mm
Illumination	adjustable reflected and transmitted LED light
Power supply	110/220V, 50/60Hz
Dimension (L×W×H)	260×190×400mm
Weight	4.3kg

### STANDARD DELIVERY

Main unit	1 pc
WF 10X eyepiece	2 pcs
Ø95mm glass plate	1 pc
Ø95mm white/black plate	1 pc
Anti-dust cover	1 pc

### OPTIONAL ACCESSORY

Auxiliary objective	0.5X	ISM-ZS30-OB05X *
	0.63X	ISM-ZS30-OB06X *
	0.75X	ISM-ZS30-OB07X *
	2X	ISM-ZS30-OB2X
Eyepiece	10X dividing eyepiece (graduation 0.1mm/div.)	ISM-ZS30-EPD10X
	WF15X (view field: Ø16mm)	ISM-ZS50-EP15X
	WF20X (view field: Ø12mm)	ISM-ZS50-EP20X
LED ring light		ISM-ZS-RL
Sleeve for auxiliary objective		ISM-ZS30-ADAPTER
Digital camera		ISM-CM63
Camera adapter 0.75X **		ISM-AD-0D75

\* 0.5X, 0.63X and 0.75X auxiliary objectives must be used with ISM-ZS30-ADAPTER

\*\* Digital camera must be used with camera adapter 0.75X

## LONG WORKING DISTANCE STEREO MICROSCOPE (LOW MAGNIFICATION)



### SPECIFICATION

Code	5305-ZS90 (with magnetic base)
Magnification	8X
Eyepiece (wide field)	10X (view field: Ø20mm)
Objective	0.8X
Pupil distance	55~75mm
Diopter adjustment	±5 diopter (one eyepiece)
Working distance of objective	115mm
Max. workpiece height	140mm
Dimension (L×W×H)	280×180×410mm
Weight	2.1kg

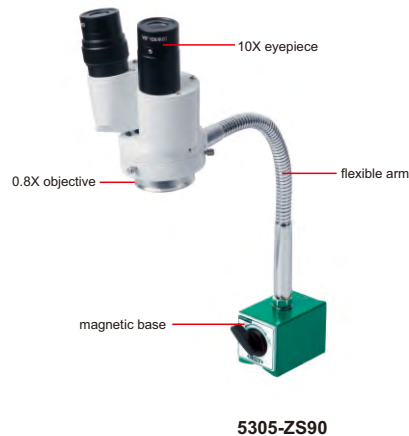

5305-ZS90



LED ring light (optional)

### STANDARD DELIVERY

Main unit	1 pc
10X eyepieces	1 pair
0.8X objective	1 pc
Anti-dust cover	1 pc

### OPTIONAL ACCESSORY

Eyepiece	WF5X (view field: Ø20mm)	5305-ZS80-EP5X
	WF15X (view field: Ø15mm)	5305-ZS80-EP15X
	WF20X (view field: Ø10mm)	5305-ZS80-EP20X
LED ring light		ISM-ZS-RL

# DIGITAL CAMERA FOR MICROSCOPES CODE ISM-CM63

**ATTENTION: ADAPTERS ARE NEEDED  
ACCORDING TO MICROSCOPES**

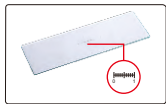

glass calibration rule  
(included, graduation 0.1mm)



VIDEO



C-mount

adapter 0.75X (optional)



application



- To be used with computers
- Sony Exmor back-illuminated CMOS sensor
- USB3.0 transmission
- Automatic exposure, gain adjustment, white balance, chrominance adjustment, saturation adjustment, gamma correction, luminance adjustment, contrast adjustment

### Measurement tools:

- measure length of line or distance between two points
- measure rectangle
- measure angle
- measure radius, girth and area of circle
- measure axis lengths, girth and area of ellipse
- calibration
- measure distance between two parallel lines
- measure width and diameter of ring
- measure diameter, length, perimeter angle of arc
- measure area of polygon
- measure center distance between two circles
- measure length of open curve

software (included)

selectable resolution

histogram  
(quantify the distribution of color and brightness)

measurement items

real time gray calibration

black balance  
(reduce color difference)

flat field correction  
(reduce brightness difference)

dark field correction  
(reduce thermal noise)

The software can control image completely, including measurement, image stitch, extend focus depth, image gray processing, RGB histogram observation, image color sampling, 3D plot(3D representation of image intensity), image exposure, white balance, black balance, image bit depth, flat field correction and dark field correction, etc.

counting

select counting tool

automatic counting

### SPECIFICATION

Sensor (back-up)	1/1.8" CMOS
Resolution	3072×2048
Pixel	6.3M
Single pixel size	2.4×2.4µm
Spectral range	380-650nm (with infrared cut filter)
Frame rate	30fps
Sampling average	1×1
Exposure time	0.1ms~15s
Power supply	USB port
Weight	400g

### COMPUTER REQUIREMENT

Operation system	Windows 7/8/10
CPU	Intel Core 2 2.8Hz or above
Memory	2GB or above
USB port	USB3.0 (recommand) or USB2.0
Display	17" or above

### STANDAER DELIVERY

Camera (USB cable included)	1 pc
Glass calibration rule (graduation 0.1mm)	1 pc
Software	1 pc

### OPTIONAL ACCESSORY

Adapter 0.75X	ISM-AD-0D75
---------------	-------------

Extend focus depth

focus on the top

focus on the bottom

clear image of both top and bottom

automatic image stitching (expand field of view)

left side

right side

after stitching

Binary

separate target and background

3D plot

Visualize the distribution of image brightness and color

## DIGITAL CAMERA FOR MICROSCOPES (WITH PAD) CODE ISM-ZS70-S

MEASUREMENT, TAKE PICTURES AND VIDEOS

ATTENTION: CAMERA CONNECTOR AND ADAPTER ARE NEEDED ACCORDING TO MICROSCOPES

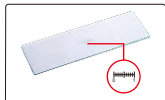

glass calibration rule (included, graduation 0.1mm)



VIDEO

- Windows 10 operation system
- Built-in software, can take pictures and videos, can measure
- Language: Chinese, English, French, Japanese, German, Polish, Arabic
- Automatic exposure, white balance, brightness, contrast ratio, saturation are adjustable
- Image process feature: zoom in/out, flip, mirror, stitching and so on
- Output to Excel or CSV file

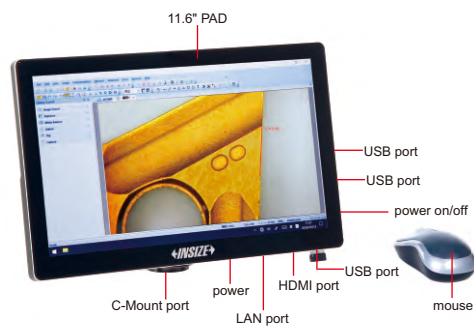

### SPECIFICATION

Sensor	1/2.3" CMOS
Pixel	16M
Resolution	800×600, 1600×1200, 1920×1080, 2048×1536, 2304×1728, 2592×1944, 4608×3456
Frame rate	30fps (1920×1080)
Output	HDMI, USB 3.0
Power supply	power adapter
Dimension (L×W×H)	280.3×177.4×12.5mm
Weight	0.9kg

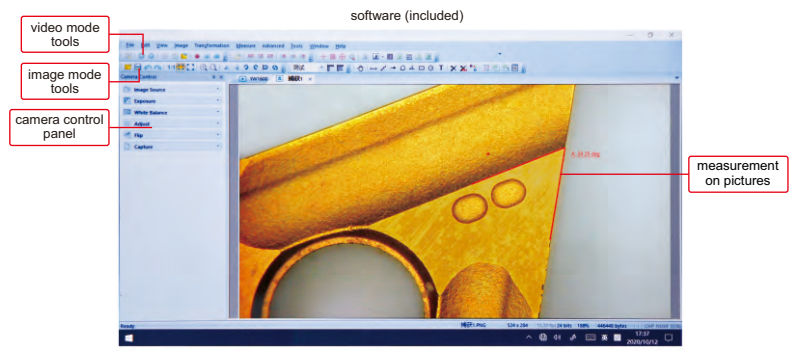

### STANDARD DELIVERY

Main unit	1 pc
Mouse	1 pc
Glass calibration rule (graduation 0.1mm)	1 pc
AC/DC adapter	1 pc

### Measurement tools

- measure line
- measure angle
- measure meander line
- measure rectangle
- arrow mark
- measure circle
- measure polygon
- text mark
- calibration
- show/hide scale

## PORTABLE MEASURING MICROSCOPE CODE ISM-PM100



### STANDARD DELIVERY

Main unit	1 pc
Pen light	1 pc
Battery (AAA)	2 pcs

### SPECIFICATION

Total magnification	100X
Eyepiece	10X with graduation
Objective (achromatic)	10X (numerical aperture: 0.25)
Working distance	7mm
Graduation	0.01mm
Viewing field	Ø1.8mm
Focus range	30mm
Illumination	LED light
Diameter of base	Ø63mm
Height	210mm
Weight	650g

## TABLE MAGNIFIER WITH ILLUMINATION CODE 7517-3D



- Four steps brightness adjustment
- LED illumination, working life 20000h
- Resin lens

### SPECIFICATION

Magnification	1.75X
Diopter	3D
Lens diameter	Ø125mm
Illumination	power: 3W, illuminance: 260lm
Power supply	power adapter 12V, 1A

## TABLE MAGNIFIER WITH ILLUMINATION CODE 7516-5D

- LED illumination, working life 20000h

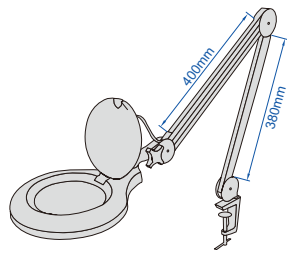

### SPECIFICATION

<b>Magnification</b>	2.25X
<b>Diopter</b>	5D
<b>Lens diameter</b>	Ø122mm
<b>Illumination</b>	power: 7W, illuminance: 420lm
<b>Power supply</b>	100~240V, 50~60Hz

## TABLE MAGNIFIERS WITH ILLUMINATION

- LED illumination, working life 20000h
- Resin lens

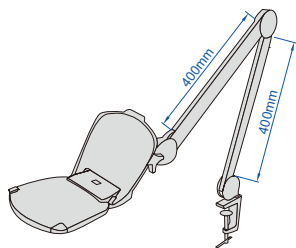

7520-320D



7521-3D

### SPECIFICATION

Code	7520-320D	7521-3D
<b>Magnification</b>	two magnifications 1.75X/6X	1.75X
<b>Diopter</b>	3D/20D	3D
<b>Lens diameter</b>	160×127mm	Ø126mm
<b>Illumination</b>	power: 6W, illumination: 550lm	
<b>Power supply</b>	power adapter 12V, 1A	

## DIGITAL MAGNIFIER CODE 7525-D4



after the handle is folded, the magnifier can be directly placed on the object for observation

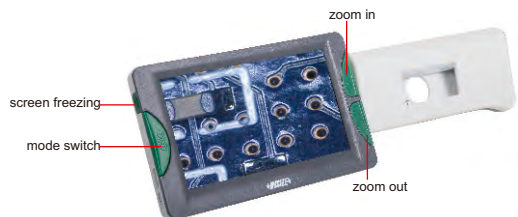

### SPECIFICATION

<b>Screen size</b>	4.3 inch
<b>Screen resolution</b>	480×272
<b>Magnification</b>	2X-32X
<b>Pixel</b>	8M
<b>Focus</b>	manual/automatic
<b>Color mode (26 modes)</b>	color mode, color enhancement mode, negative mode, monochrome mode, black on white, white on black, blue on white, white on blue, yellow on black, black on yellow, yellow on blue, blue on yellow, green on white, white on green, orange on white, white on orange, red on black, black on red, orange on black, black on orange, yellow on green, green on yellow, red on white, white on red yellow on white, white on yellow
<b>Output</b>	TV
<b>Charging port</b>	Type-C
<b>Lithium battery</b>	1600mAH (for 4 hours working)
<b>Dimension (L×W×H)</b>	123×39×76mm (when the handle is folded)
<b>Weight</b>	210g

- 720P60 camera
- Auto focus
- With screen freezing function
- 26 color modes can be switched to meet the needs of different people
- Port to TV
- Automatic shutdown after 3 minutes

### STANDARD DELIVERY

<b>Main unit</b>	1 pc
<b>Video output cable</b>	1 pc
<b>USB charging cable</b>	1 pc
<b>Power adapter</b>	1 pc

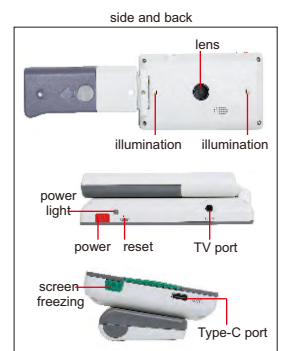



## DIGITAL MAGNIFIER CODE 7526-D5

- 720P60 (close view) and 1080P30 (far view) cameras
- Double autofocus
- 26 color modes can be switched to meet the needs of different people
- Adopt folding bracket
- Detachable handle design, suitable for left-handed or right-handed use
- TV and HDMI ports to TV and display
- Automatic shutdown after 3 minutes

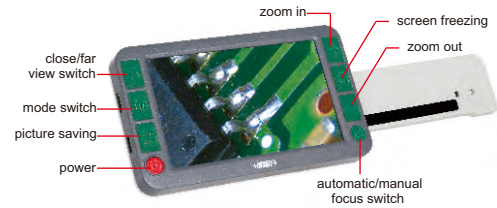

### SPECIFICATION

Screen size	5 inch
Screen resolution	800x480
Magnification	2X-32X
Close view pixel	8M
Far view pixel	8M
Focus	manual/automatic
Color mode (26 modes)	color mode, color enhancement mode, negative mode, monochrome mode, black on white, white on black, blue on white, white on blue, yellow on black, black on yellow, yellow on blue, blue on yellow, green on white, white on green, orange on white, white on orange, red on black, black on red, orange on black, black on orange, yellow on green, green on yellow, red on white, white on red, yellow on white, white on yellow
Line	horizontal and vertical red lines
Function	screen freezing, image moving, photo playback, and high definition storage
Output	TV and HDMI
storage	supports up to 32G TF card
Charging port	Type-C
Lithium battery	2500mAH (for 4 hours working)
Dimension (L×W×H)	145×30×85mm (when the handle is folded)
Weight	275g

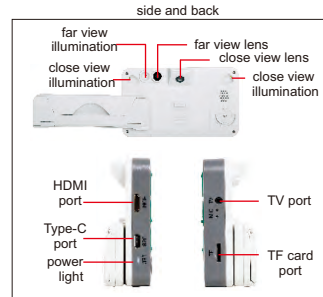

after the handle is folded, the magnifier can be directly placed on the object for observation



horizontal and vertical red lines

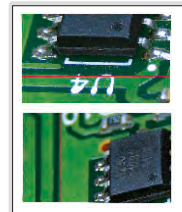

### STANDARD DELIVERY

Main unit	1 pc
HDMI cable	1 pc
Video output cable	1 pc
USB charging cable	1 pc
Power adapter	1 pc

## FOLDING MAGNIFIER

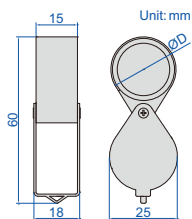

7511-8

- Glass lens

closed



Code	Magnification	Lens diameter (ØD)
7511-8	10X	Ø21mm

## FOLDING MAGNIFIER WITH ILLUMINATION

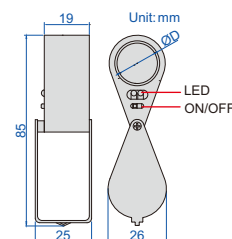

7515-10



2 pcs LED

- Resin lens
- Powered by 3×LR927 batteries (included)

closed



Code	Magnification	Lens diameter (ØD)
7515-10	10X	Ø21mm

## FOLDING MAGNIFIER WITH ILLUMINATION

- Resin lens
- Powered by 2×CR1620 batteries (included)
- LED lights up automatically when opened



7514-1



closed

LED lights up when opened

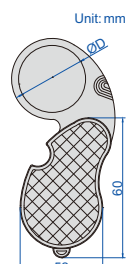

Code	Magnification	Lens diameter (ØD)
7514-1	2.5X	Ø45mm

## MEASURING MAGNIFIERS (WITH ILLUMINATION)

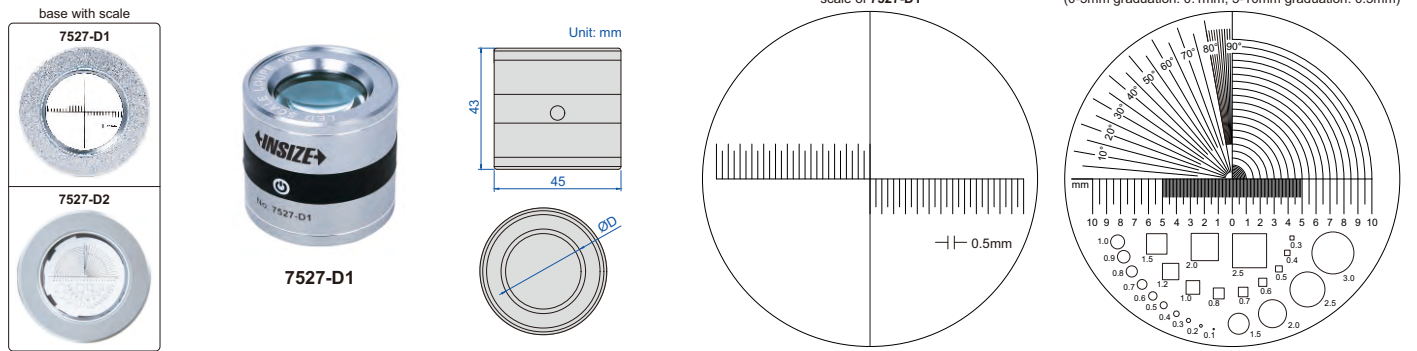

- Base with scale
- With 5 white LED and 5 UV LED
- Charging port: Type-C
- Work for 1.5h after fully charged

Code	Magnification	Lens diameter (ØD)
7527-D1	10X	Ø30mm
7527-D2	10X	Ø30mm

## MAGNIFIER WITH ILLUMINATION



- Glass lens
- Powered by 3xAG7 batteries
- 3 pcs LED and 3 pcs UV
- Base with scale, graduation: 0.5mm, 1/16"

Code	Magnification	Lens diameter (ØD)
7524-10	10X	Ø30mm

## MAGNIFIER WITH ILLUMINATION

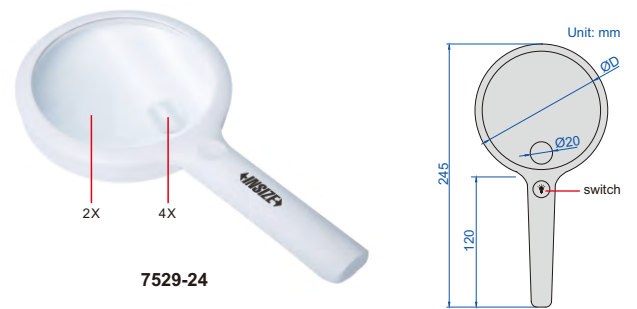

- Resin lens
- With 20 white LED, three levels brightness adjustment
- Charging port: Type-C

Code	Magnification	Lens diameter (ØD)
7529-24	2X/4X	Ø105mm

## MAGNIFIER WITH ILLUMINATION

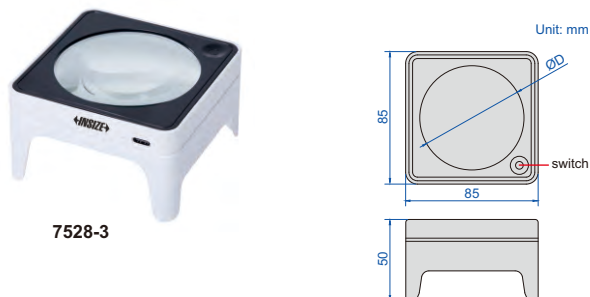

- Glass lens
- With 4 white LED, three levels brightness adjustment
- Charging port: Type-C

Code	Magnification	Lens diameter (ØD)
7528-3	3X	Ø70mm

## MAGNIFIERS WITH ILLUMINATION



- Glass lens
- Powered by 3xAAA batteries (included)

Code	Magnification	Lens diameter (ØD)	L
7513-2	2X	Ø75mm	170mm
7513-4	4X	Ø50mm	145mm



### MAGNIFIER WITH TWO LENSES



- Resin lens
- Interchangeable lenses
- Powered by 3 pcs AAA batteries (included)

Code	Lens number	Magnification	Lens diameter (ØD)
7522-610	2 pcs	10X	37mm
		6X	50mm

### MAGNIFIER



- Resin lens
- Silicone hose can be shaped according to needs
- Can be used on table or hanging around neck

Code	Magnification	Lens size
7530-1D8	1.8X	180x120mm

### THREE WAYS MAGNIFIER WITH ILLUMINATION

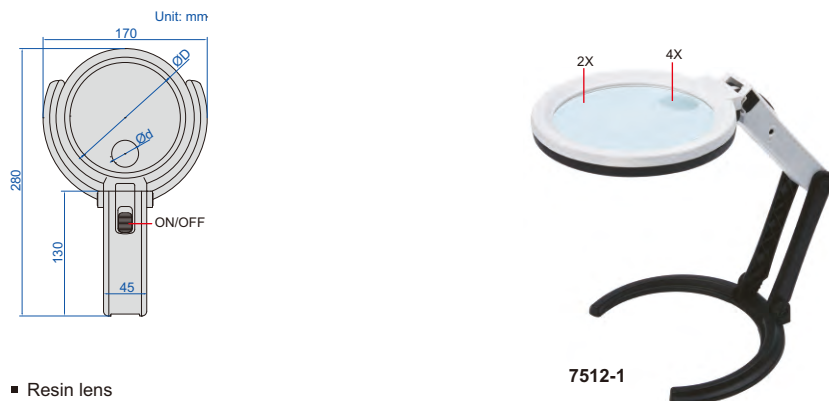

- Resin lens
- Powered by 2xAA batteries (included) or power adapter (110~240V, 50~60Hz)

Code	Magnification	Lens diameter (ØD/Ød)
7512-1	2X/4X	Ø120mm/Ø28mm



### MAGNIFICATION GLASSES

- Resin lens
- Interchangeable lenses
- Powered by 3 pcs AAA batteries (included)



7523-3D5

Code	Lens number	Magnification
7523-3D5	5 pcs	1X
		1.5X
		2X
		2.5X
		3.5X

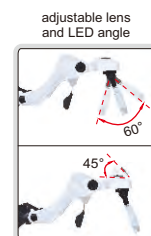

### TELESCOPING INSPECTION MIRRORS

- Inspect hidden areas
- Rotation of the mirror: 360°
- Length of handle is adjustable, handle is made of stainless steel

Code	Size of mirror	Length
7160-1	Ø32mm	178~515mm
7160-2	50x90mm	330~490mm

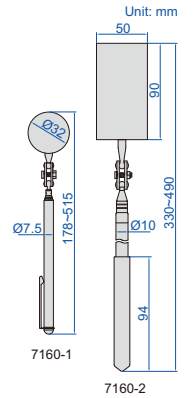

### TELESCOPING INSPECTION MIRROR (WITH ILLUMINATION)

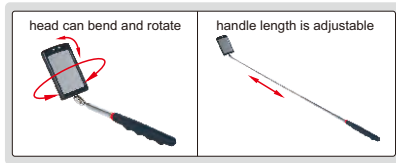

- Inspect hidden areas
- Head can bend and rotate
- Telescoping handle, made of stainless steel
- With two CR2032 batteries

Code	Size of mirror	Length
7162-1	65x42mm	285~875mm

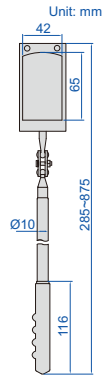

### FLEXIBLE PICK-UP AND FLASHLIGHT

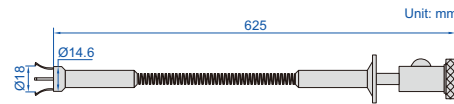
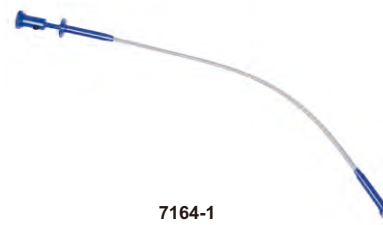

- For illumination and pick up steel parts in hidden areas
- Flexible spring rod, made of stainless steel
- Three LR44 batteries

Code	Magnetic force	Flashlight range	Battery life
7164-1	0.9kgf	1m	24h



### TELESCOPING MAGNETIC PICK-UP AND FLASHLIGHT



- Magnetic force of the head: 2kgf
- Magnetic force of the end: 4kgf
- For illumination and pick up steel parts in hidden areas
- Head can bend
- Telescoping handle, made of stainless steel
- Magnetic head and end
- With four LR44 batteries

Code	Flashlight range	Battery life	Length
7163-1	3m	8h	172~568mm

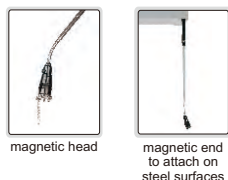
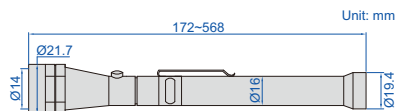

### TELESCOPING MAGNETIC PICK-UP

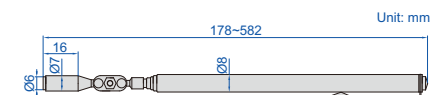

- Pick up metal parts from hidden areas
- Rotation of the magnetic head: 360°
- Length of handle is adjustable, handle is made of stainless steel

Code	Size of magnetic tip	Magnetic force	Length
7161-1	Ø6mm	0.45kgf	178~582mm

# VIDEOSCOPES



REAR FIBER ILLUMINATION

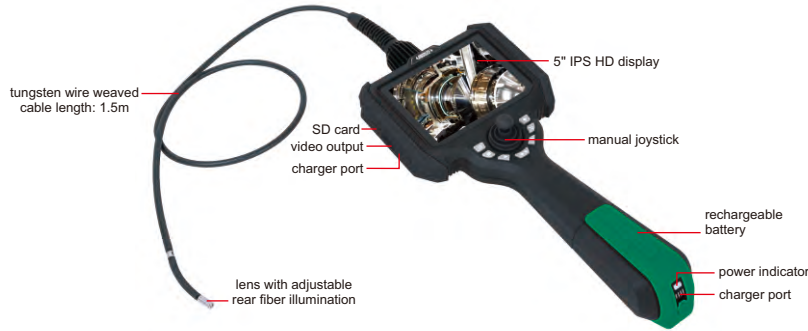

ISV-K6015

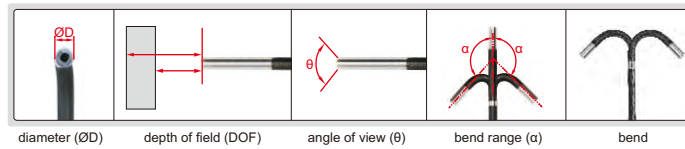

## SPECIFICATION

Code		ISV-K3915	ISV-K6015
Lens	diameter (ØD)	3.9mm	6.0mm
	pixel	0.92M	
	resolution	1280×720	
	depth of field	8-150mm	12-200mm
	bending direction	four directions	
	bending range (α)	±160°	
	angle of view (θ)	120°	
	illumination	rear fiber	
	lens	sapphire glass lens	
	dust/waterproof	IP67	
Cable	bend control	manual joystick	
	length	1.5m	
Main unit	type	tungsten wire weaved cable	
	display	5" high definition LCD	
	function	take pictures, take videos	
	file format	picture: JPG, video: MP4	
	image process	image zoom (1X, 2X, 3X, 4X)	
	image control	freeze, flip over, playback and analog ruler	
	memory	memory card	
	output	USB, HDMI	
	power supply	rechargeable lithium battery (working time ≥ 4hours), AC/DC adapter (for continuous working)	
	Weight	1000g	

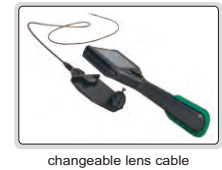

## OPERATION ENVIRONMENT

Main unit	-10~50°C, no preheat
Operation temperature	-20~70°C
Storage temperature	-20~60°C
Relative humidity	maximum 90%, no condensation

## STANDARD DELIVERY

Main unit	1 pc
32G SD card	1 pc
Card reader	1 pc
USB cable	1 pc
Tripod	1 pc
AC/DC adapter	1 pc

## OPTIONAL ACCESSORY

WiFi output	ISV-K-WIFI (must be installed in factory, only for Android OS)
Temperature alarm	ISV-K-HTALARM (must be installed in factory)
Hook	ISV-K-HOOK (must be installed in factory)
Magnet	ISV-K-MAGNET (must be installed in factory)
Clamp	ISV-K-CLAMP

## MOBILE PHONE VIDEOSCOPE CODE ISV-P6



For Android and IOS mobile phones

### SPECIFICATION

Diameter of lens (ØD)	6±0.2mm
Length of cable	1m
Resolution	960×720, 1280×720 (switchable)
Depth of field	20mm~∞
Angle of view (θ)	100°
Bending range (α)	0~180°
Illumination	LED with 3 levels control
Cable type	wear resistant
Interface	USB, type-C
Mobile phone system	Android, IOS
Power supply	rechargeable battery (for 2 hours working)
Dimension (L×W×H)	195×57×105mm
Weight	450g

mobile phone (optional)

charge port

video output

manual joystick to bend the lens in any direction

indicator light

cable length: 1m

lens with adjustable illumination

the clamping range of mobile phone bracket L=56-95mm

bending of lens up to 180°

angle of view θ=100°

lens with LED

bend in any direction

### STANDARD DELIVERY

Main unit (with cable)	1 pc
Type-C cable	1 pc
Micro USB cable	1 pc
Iphone cable	1 pc
Charging cable	1 pc

## VIDEOSCOPE (BASIC TYPE) CODE ISV-S106



TUNGSTEN WIRE WEAVED CABLE  
BREAK AND WEAR RESISTANCE

### SPECIFICATION

Lens	diameter (ØD)	6mm
	pixel	1M
	resolution	1280×720
	depth of field	20~150mm
	bending direction	360°
	bending range (α)	0°~220°
	angle of view (θ)	120°
	illumination	7 pcs LED, with 6 levels control
	illuminance	25000Lux
	lens	sapphire glass lens
	dust/waterproof	IP67
	bend control	manual joystick
	temperature alarm	temperature sensor (optional)
Cable	length	1.5m
	type	tungsten wire weaved cable
Main unit	display	3.5" IPS full-view display
	display resolution	640×480
	function	take pictures, take videos
	file format	picture: JPG, video: MP4
	image process	image zoom (1X, 2X, 3X, 4X, 5X)
	memory	memory card (maximum: 64G)
	output	USB, HDMI, WIFI (optional)
	dust/waterproof	IP65
power supply	rechargeable lithium battery (working time ≥ 3 hours; optional: additional battery, working time ≥ 9 hours) AC/DC adapter (for continuous working)	
Weight	1000g	

video output

charger

SD card

3.5" IPS HD full-view display

tungsten wire weaved cable length: 1.5m

lens with adjustable LED illumination

220° bending angle

LED 6 levels control

120° view angle

360° bending direction

### STANDARD DELIVERY

Main unit (with cable & lens)	1 pc
16G SD card	1 pc
Card reader	1 pc
USB cable	1 pc
Battery	1 pc
AC/DC adapter	1 pc

### OPTIONAL ACCESSORY

Additional battery	ISV-S106-BATTERY (must be installed in factory)
WIFI output	ISV-S106-WIFI
Temperature alarm	ISV-S106-HT-ALARM

## VIDEOSCOPE (BASIC TYPE) CODE ISV-E40



MEMORY CABLE CAN BE  
FIXED AT ANY SHAPE

**IP67**  
WATERPROOF



hook (included)



magnet pick up (included)



45° mirror (included)

lens with 8 pcs LED  
adjustable illumination



memory cable

### SPECIFICATION

Lens	diameter (ØD)	8mm
	pixel	0.92M
	resolution	1280x720
	depth of field	30~80mm
	angle of view	77°
	illumination	3 levels
	dust/waterproof	IP67
Cable	length	1180mm
	type	memory (can be set at any shape)
Main unit	display	5" IPS LCD
	function	take picture, take video
	file format	picture: JPG, video: MOV
	image process	image zoom (1.5X, 2X, 3X, 4X)
	memory	memory card (optional)
	output	type-C
	power supply	rechargeable lithium battery (for 5 hours working)
dimension	217×155×131mm	
Weight		506g

### STANDARD DELIVERY

Main unit	1 pc
45° mirror	1 pc
Hook	1 pc
Magnet pick up	1 pc

### OPTIONAL ACCESSORY

32G memory card	ISV-E40-CARD
Card reader	ISV-E40-READER

### OPERATION ENVIRONMENT

Operation temperature	-10~50°C
Storage temperature	-20~60°C
Operation humidity	15%~85%

## VIDEOSCOPE (ECONOMIC TYPE) CODE ISV-E30

**IP67**  
WATERPROOF

MEMORY CABLE CAN BE  
FIXED AT ANY SHAPE



### SPECIFICATION

Lens	diameter	5.2mm
	pixel	0.4M
	depth of field	30~80mm
	angle of view	72°
	illumination	8 levels
	dust/waterproof	IP67
Cable	length	1m
	type	memory (can be set at any shape)
Main unit	display	4.3" LCD
	function	take picture, take video
	file format	picture: JPG, video: AVI
	image zoom	2X
	memory card	memory card (optional)
	output	micro USB
	power supply	AA battery
dimension	154×32.5×87.5mm	
Weight		280g

lens  
(adjustable illumination)

memory cable  
length: 1m



cable can be wrapped around the main unit



hook (included)



magnet pick up (included)

### STANDARD DELIVERY

Main unit	1 pc
Hook	1 pc
Magnet pick up	1 pc
AA battery	4 pcs

### OPTIONAL ACCESSORY

32G memory card	ISV-E40-CARD
Card reader	ISV-E40-READER

### OPERATION ENVIRONMENT

Operation temperature	-10~50°C
Storage temperature	-20~60°C
Operation humidity	15%~85%

## COATING THICKNESS GAGE (HIGH PRECISION) CODE ISO-8000FN

FOR MAGNETIC AND  
NON-MAGNETIC SUBSTRATES

SUITABLE FOR THIN  
COATING BELOW 10 $\mu$ m



calibration foils (included)



stand (optional)



eddy current probe N2000  
(optional)



zero calibration plate  
(included)



eddy current probe N1500  
(optional)



magnetic induction  
probe (included)

- Can measure thickness of thin coating below 10 $\mu$ m
- High repeatability
- Magnetic induction probe measures the thickness of non-magnetic coating and non-metallic coating on magnetic metal substrate  
Substrate: iron, steel, magnetic stainless steel (not for non-magnetic stainless steel)  
Coating: zinc, aluminum, copper, chrome, tin, plastic, powder, paint (not for nickel)
- Eddy current probe measures the thickness of non-conductive coating on non-magnetic metal substrate  
Substrate: copper, aluminum, zinc, non-magnetic stainless steel  
Coating: plastic, powder, paint, anodizing (not for chrome and zinc plating)
- Maximum, minimum, average and variance values can be calculated automatically



### SPECIFICATION

<b>Probe</b>	magnetic induction probe (included)		eddy current probe (optional)*	
<b>Measuring range</b>	0~500 $\mu$ m		0~1500 $\mu$ m	0~2000 $\mu$ m
<b>Resolution</b>	0.1 $\mu$ m (range<100 $\mu$ m) 1 $\mu$ m (100 $\mu$ m $\le$ range $\le$ 500 $\mu$ m)		0.1 $\mu$ m (range<100 $\mu$ m) 1 $\mu$ m (100 $\mu$ m $\le$ range<1000 $\mu$ m) 0.01mm (1.00mm $\le$ range $\le$ 1.50mm)	0.1 $\mu$ m (range<100 $\mu$ m) 1 $\mu$ m (100 $\mu$ m $\le$ range<1000 $\mu$ m) 0.01mm (1.00mm $\le$ range $\le$ 2.00mm)
<b>Accuracy</b>	$\pm(0.5+2\%L)\mu$ m L is measuring thickness in $\mu$ m			
<b>Repeatability</b>	$\le(0.2+0.8\%L)\mu$ m L is measuring thickness in $\mu$ m		$\le(0.2+1\%L)\mu$ m L is measuring thickness in $\mu$ m	
<b>Measuring mode</b>	single and continuous			
<b>Measure interval</b>	<b>single mode</b>	1.5s	0.8s	
	<b>continuous mode</b>	0.4s	0.4s	
<b>Calibration mode</b>	zero calibration and multi-points calibration (1~5 points)			
<b>Minimum substrate thickness</b>	0.1mm		0.05mm	
<b>Minimum measuring area</b>	$\varnothing$ 7mm		$\varnothing$ 25mm	
<b>Minimum radius of curvature workpieces</b>	<b>convex surface</b>	1.5mm		
	<b>concave surface</b>	10mm		
<b>Unit</b>	$\mu$ m/mil			
<b>Power supply</b>	4 $\times$ 1.5V AAA batteries			
<b>Dimension</b>	148 $\times$ 76 $\times$ 26mm			
<b>Weight</b>	148g			

### STANDARD DELIVERY

Main unit	1 pc
Magnetic induction probe	1 pc
Zero calibration plate	1 pc
Calibration foils (5.6 $\mu$ m, 11.6 $\mu$ m, 24.6 $\mu$ m, 50.0 $\mu$ m, 100 $\mu$ m, 252 $\mu$ m, 390 $\mu$ m)	1 set
1.5V AAA battery	4 pcs

### OPTIONAL ACCESSORY

Eddy current probe (with zero calibration plate)	ISO-8000FN-N1500*
Stand	ISO-8000FN-N2000
	ISO-8000FN-STAND

\*For precision measurement of thin coating below 10 $\mu$ m, please use the stand for eddy current probe



# COATING THICKNESS GAGE CODE 9501-1200

**POPULAR  
MODEL**

**FOR MAGNETIC AND  
NON-MAGNETIC SUBSTRATES**

**DATA  
OUTPUT**

**BLUETOOTH**



- Magnetic induction probe (FE) measures the thickness of non-magnetic coating and non-metallic coating on magnetic metal substrate.  
Substrate: iron, steel, magnetic stainless steel (not for non-magnetic stainless steel)  
Coating: zinc, copper, chrome, tin, plastic, powder, paint (not for nickel)
- Eddy current probe (NFE) measures the thickness of non-conductive coating on non-magnetic metal substrate.  
Substrate: copper, aluminum, zinc, non-magnetic stainless steel  
Coating: plastic, powder, paint, anodizing (not for chrome and zinc plating)
- Tolerance measurement
- Data statistic, including average, variance, maximum and minimum values
- Data can be sent to Excel by connecting to computers via bluetooth or cable of receiver
- Support bluetooth printer
- Automatic power off

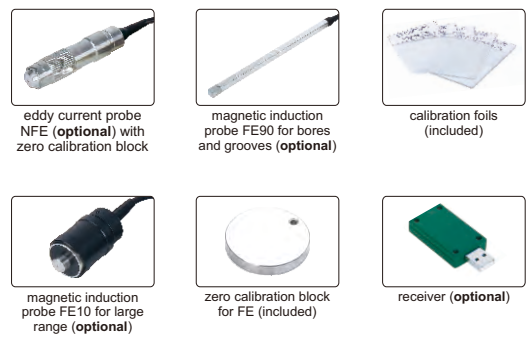

## SPECIFICATION

Probe type	FE (included) magnetic induction probe	NFE (optional) eddy current probe	FE90 (optional) magnetic induction probe for bores and grooves	FE10 (optional) magnetic induction probe for large range
Measuring range	0~1250µm	0~1250µm	0~1250µm	500~10000µm
Accuracy	$\pm(3\%L+1)\mu\text{m}$ (range $\leq 1250\mu\text{m}$ ) $\pm(3\%L+10)\mu\text{m}$ (range $> 1250\mu\text{m}$ ) L is measuring thickness in µm			
Resolution	0.1µm (range $< 100\mu\text{m}$ ) 1µm (range $\geq 100\mu\text{m}$ )			
Measuring mode	continuous and single			
Minimum substrate thickness	0.5mm	0.3mm	0.5mm	2mm
Minimum measuring area	Ø7mm	Ø5mm	Ø7mm	Ø40mm
Minimum curvature radius of convex workpiece	1.5mm	3mm	—	10mm
Memory	600			
Output	USB			
Power supply	2×1.5V AA batteries			
Dimension	135×77×32mm			
Weight	172g			

## STANDARD DELIVERY

Main unit	1 pc
Magnetic induction probe (FE)	1 pc
Zero calibration block for FE probe	1 pc
Calibration foils (50/100/250/500/1000µm)	1 set
1.5V AA battery	2 pcs
Software and USB cable	1 pc

## OPTIONAL ACCESSORY

Receiver	ISR-C300-RECEIVER
Cable of receiver	9501-1200-CABLE
Bluetooth printer	ISR-C002-PRINTER
Eddy current probe (NFE) with zero calibration block	9501-1200-NFE
Magnetic induction probe (FE90) for bores and grooves	9501-1200-FE90
Magnetic induction probe (FE10) for large range	9501-1200-FE10

## COATING THICKNESS GAGE (BASIC TYPE) CODE ISO-1200FN

FOR MAGNETIC AND  
NON-MAGNETIC SUBSTRATES



- Probe is suitable for both magnetic and non-magnetic metal substrates
- Can measure the thickness of non-magnetic coating and non-metallic coating on magnetic metal substrate  
Substrate: iron, steel, magnetic stainless steel (not for non-magnetic stainless steel)  
Coating: zinc, aluminum, copper, chrome, tin, plastic, powder, paint (not for nickel)
- Can measure the thickness of non-conductive coating on non-magnetic metal substrate  
Substrate: copper, aluminum, zinc, non-magnetic stainless steel  
Coating: plastic, powder, paint, anodizing (not for chrome and zinc plating)
- 3 measuring modes: Fe, NFe, Fe/NFe
- Store 9 measuring records
- Small and portable, easy for operation

### SPECIFICATION

Measuring range	0~2000 $\mu$ m	
Resolution	0.1 $\mu$ m (range<100 $\mu$ m) 1 $\mu$ m (100 $\mu$ m $\le$ range<1000 $\mu$ m) 0.01mm (1mm $\le$ range $\le$ 2mm)	
Accuracy	$\pm(2\mu\text{m}+3\%L)$ L is measuring thickness in $\mu$ m	
Measure interval	0.5s	
Calibration mode	zero calibration	
Measuring mode	Fe, NFe, Fe/NFe	
Minimum substrate thickness	Fe	0.2mm
	NFe	0.05mm
Minimum measuring area	$\varnothing$ 25mm	
Minimum radius of curvature workpieces	convex surface	5mm
	concave surface	25mm
Unit	$\mu$ m/mil	
Power supply	2 $\times$ 1.5V AAA batteries	
Main unit dimension	101 $\times$ 62 $\times$ 28mm	
Probe dimension	71 $\times$ 26 $\times$ 22mm	
Weight	114g	

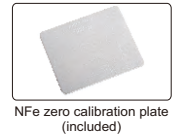
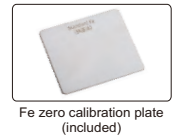

### STANDARD DELIVERY

Main unit	1 pc
Fe zero calibration plate	1 pc
NFe zero calibration plate	1 pc
Standard foil (100 $\mu$ m)	1 pc
1.5V AAA battery	2 pcs

## COATING THICKNESS GAGE (BASIC TYPE) CODE ISO-1000FN

FOR MAGNETIC AND  
NON-MAGNETIC SUBSTRATES



- Probe is suitable for both magnetic and non-magnetic metal substrates
- Can measure the thickness of non-magnetic coating and non-metallic coating on magnetic metal substrate  
Substrate: iron, steel, magnetic stainless steel (not for non-magnetic stainless steel)  
Coating: zinc, aluminum, copper, chrome, tin, plastic, powder, paint (not for nickel)
- Can measure the thickness of non-conductive coating on non-magnetic metal substrate  
Substrate: copper, aluminum, zinc, non-magnetic stainless steel  
Coating: plastic, powder, paint, anodizing (not for chrome and zinc plating)
- 3 measuring modes: Fe, NFe, Fe/NFe
- Store 9 measuring records
- Small and portable, easy for operation

### SPECIFICATION

Measuring range	0~2000 $\mu$ m	
Resolution	0.1 $\mu$ m (range<100 $\mu$ m) 1 $\mu$ m (100 $\mu$ m $\le$ range<1000 $\mu$ m) 0.01mm (1mm $\le$ range $\le$ 2mm)	
Accuracy	$\pm(2\mu\text{m}+3\%L)$ L is measuring thickness in $\mu$ m	
Measure interval	0.5s	
Calibration mode	zero calibration	
Measuring mode	Fe, NFe, Fe/NFe	
Minimum substrate thickness	Fe	0.2mm
	NFe	0.05mm
Minimum measuring area	$\varnothing$ 25mm	
Minimum radius of curvature workpieces	convex surface	5mm
	concave surface	25mm
Unit	$\mu$ m/mil	
Power supply	2 $\times$ 1.5V AAA batteries	
Dimension	101 $\times$ 62 $\times$ 28mm	
Weight	79g	

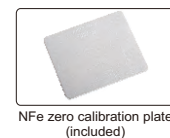
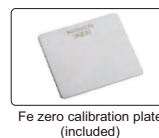

### STANDARD DELIVERY

Main unit	1 pc
Fe zero calibration plate	1 pc
NFe zero calibration plate	1 pc
Standard foil (100 $\mu$ m)	1 pc
1.5V AAA battery	2 pcs

## SURFACE PROFILE GAGE

measure peak-to-valley height of blast cleaned surface

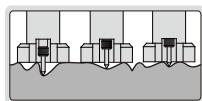

- Measure peak-to-valley height of blast cleaned surface. If the profile is too low, the adhesion of the coating to the surface will be reduced. If the profile is too high, there is the danger that the profile peaks will remain uncoated, allowing rust spots to occur.
- Meet ASTM D 4417-B
- Zero set block is included, set zero before measurement
- Stainless steel base



2344-1

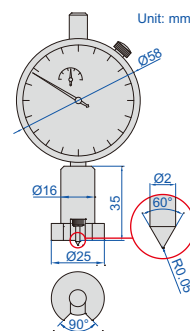

Code	Range	Dial indicator stroke	Dial indicator graduation	Accuracy
2344-1	0-1mm	1mm	0.001mm	±0.005mm

## WET FILM GAGES



4845-1

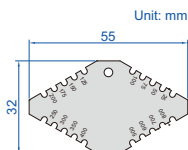

4845-1



4845-2

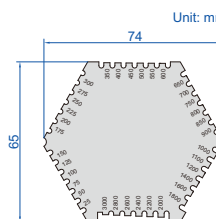

4845-2

- Made of stainless steel

Code	Range	Accuracy	Thickness
4845-1	25-800µm	±5µm	1.8mm
4845-2	25-3000µm	25-100µm: ±5µm 100µm-3000µm: ±5%	1mm

## HOLIDAY DETECTOR CODE 9511-HA30



- Inspect anti-corrosion coating status of different thickness with adjustable pulse high-voltage, coating includes insulating paint, glass lining, rubber lining, glass fiber reinforced plastic, coal tar epoxy, etc
- When the brush with pulse high-voltage moves near the crack, pinhole or thin area on the coating surface, which results in gap gas breakdown and discharge spark, sound and light alarm will appear on the probe and the alarm sound can be heard with the headphone
- LCD display with light-control backlight
- Built-in rechargeable battery, easy to carry and suitable for outdoor inspection
- Automatic power off



strip brush (included)

### SPECIFICATION

Measuring range	0.05~10mm (customization for inspecting coating thicker than 10mm is available)
Output voltage	0.6~30.0kV (stepless adjustable)
Resolution	0.1kV
Power	≤5W
Power supply	12V rechargeable Ni-MH battery
Dimension	220×130×88mm
Weight	2.5kg

### STANDARD DELIVERY

Main unit	1 pc
Probe	1 pc
Strip brush*	1 pc
Flat brush	1 pc
Ground wire	1 pc
Ground rod	1 pc
Headphone	1 pc
AC/DC adapter	1 pc

\* Arc brush and circular probe can be customized



headphone (included)



flat brush (included)

## 60° GLOSS METER (BASIC TYPE) CODE 5702-DG6



- To test the gloss of coating, such as painting, varnish, printing ink, etc.
- To test the material surfaces, such as metal, granite, ceramic, plastic, paper, etc.
- According to ISO 2813, ISO 7668, ASTM D523, ASTM D2457, DIN 67530
- Automatic judgement after setting high and low limits
- Automatic power off



base with calibration block  
(included)

### SPECIFICATION

Incidence angle	60°
Measuring range	0~200GU
Resolution	0.1GU
Accuracy	±1.5GU (range<120GU) ±1.5% (range≥120GU)
Repeatability	0.2GU (range<120GU) 0.2% (range≥120GU)
Zero error	0.1GU
Measuring area	20×10mm
Power supply	rechargeable battery
Data port	USB
Dimension	135×45×75mm
Weight	237g

### STANDARD DELIVERY

Main unit	1 pc
Base with calibration block	1 pc
U disk	1 pc
AC/DC adapter	1 pc
USB data cable	1 pc
Cleaning cloth	1 pc

software (included), test can be controlled from the software, display test data and report

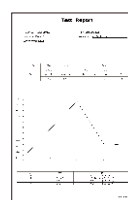

report



software

measurement data is sent to Excel

## 60° GLOSS METER CODE ISQ-DG6



- To test the gloss of coating, such as painting, varnish, printing ink, etc.
- To test the material surfaces, such as metal, granite, ceramic, plastic, paper, etc.
- According to ISO 2813, ASTM D2457, ASTM D523
- Automatic power off



base with calibration block  
(included)



### SPECIFICATION

Incidence angle	60°
Measuring range	0~150GU
Resolution	0.1GU
Accuracy	±1.2GU
Repeatability	0.4GU
Zero set error	0.2GU
Measuring area	20×10mm
Output	bluetooth
Power supply	1×1.5V AA battery
Dimension	123×38×65mm
Weight	300g

### STANDARD DELIVERY

Main unit	1 pc
Base with calibration block	1 pc
Spare calibration block	1 pc

connect mobile phone via bluetooth  
(only Android system)



operate and output data by mobile phone

## 20°/60°/85° GLOSS METER CODE ISQ-DG8

DATA  
OUTPUT

BLUETOOTH

CAN BE OPERATED BY  
COMPUTERS OR MOBILE PHONES



software flash disk  
(included)



base with calibration block  
(included)



- To test the gloss of coating, such as painting, varnish, printing ink, etc.
- To test the material surfaces, such as metal, granite, ceramic, plastic, paper, etc.
- According to ISO 2813, ASTM D2457, ASTM D523
- Memory of 10000 measurement results for browsing and output
- Automatic power off

connect to mobile phone via bluetooth  
(only Android system)



operate and output data by mobile phone

software (included), test can be controlled from the software,  
display test data, output to Excel

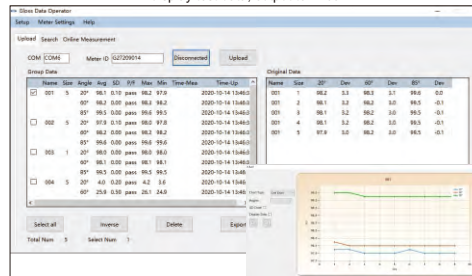

connect to computer via bluetooth or USB cable

bluetooth receiver  
(included)



### SPECIFICATION

Incidence angle	20°	60°	85°
Measuring range	0~2000GU	0~1000GU	0~160GU
Resolution	0.1GU (range≤119.9GU) 1GU (range>119.9GU)		
Accuracy	±1.5GU (range≤119.9GU) ±1.5% (range>119.9GU)		
Repeatability	0.2GU (range≤119.9GU) 0.2% (range>119.9GU)		
Zero set error	0.2GU		
Measuring area	10×9mm	16×9mm	39×5mm
Output	USB and bluetooth		
Power supply	1×1.5V AA battery		
Dimension	155×48×75mm		
Weight	400g		

### STANDARD DELIVERY

Main unit	1 pc
Base with calibration block	1 pc
Software and USB cable	1 pc
Bluetooth receiver	1 pc

# SPECTROPHOTOMETER CODE 5701-D40

THREE KINDS  
OF APERTURE

MATCHING COLOR  
CARD QUICKLY

GRATING  
SPECTROPHOTOMETRIC

DATA  
OUTPUT



connect to computer

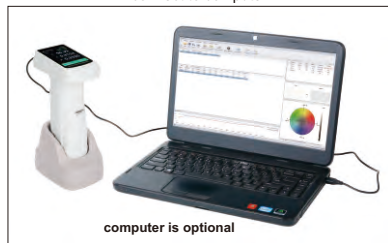

computer is optional



measurement



white calibration cavity (included)



- Conforms with CIE No.15, ISO7724-1, ASTM E1164 and DIN5033 Teil7 standards
- Grating spectrophotometric, 3.5" IPS full color screen, dual optical path high precise CMOS array sensor
- Use long life and low power consumption combined LED light source, include UV and exclude UV measurement
- Camera locating function, switchable 11mm/6mm/1×3mm aperture
- Large capacity storage space, over 20,000 measurement data
- Two standard observer angles, a variety of illuminant, a variety of color indexes, conforms with a variety of standard colorimetric data
- Measure sample spectra, accurate Lab data, can be used in color matching and accurate color transmission

software (included), test can be controlled from the software, display test data, report

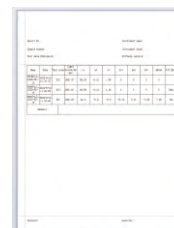

text report

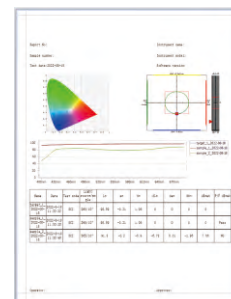

graphic report

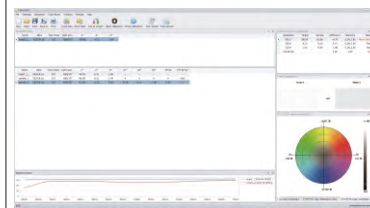

software

## SPECIFICATION

Optical geometry	D/8 (diffused illumination/8° direction reception) SCI+SCE (specular component included+specular component excluded)	
Integrating sphere size	Ø40mm	
Light source	LED (full band balanced LED)+UV	
Spectrophotometric mode	grating	
Sensor	dual optical path high precise CMOS array sensor	
Wavelength range	400~700nm	
Wavelength interval	10nm	
Reflectance measurement range	0~200%	
Reflectance resolution	0.01%	
Display resolution	0.01	
Illumination area/aperture	MAV: Ø11mm; SAV: Ø6mm; MINI: 1×3mm	
Color space	CIE-Lab, CIE-LCh, HunterLab, CIE Luv, XYZ, Yxy, RGB	
Color difference formula	$\Delta E^*ab$ , $\Delta E^*cmc$ , $\Delta E^*94$ , $\Delta E^*00$	
Other colorimetric index	whiteness (ASTM E313-00, ASTM E313-73, CIE/ISO, AATCC, Hunter, Taube Berger Stensby), Yellowness (ASTM D1925, ASTM 313-00, ASTM E313-73), Blackness (My, dM), Color fastness, Tint (ASTM E313-73) Color density CMYK (A, T, E, M), Milm, Munsell, Opacity, Color strength	
Observer angle	2°/10°	
Illuminant	A, B, C, D50, D55, D65, D75, F1, F2, F3, F4, F5, F6, F7, F8, F9, F10, F11, F12, CWF, U30, U35, DLF, NBF, T183, T184, Id50, Id65, LED-B1, LED-B2, LED-B3, LED-B4, LED-B5, LED-BH1, LED-RGB1, LED-V1, LED-V2	
Measuring time	about 1.5s	
Repeatability	spectral reflectance	within 0.08% of standard deviation
	colorimetric values	$\Delta E^*ab \leq 0.025$ (after whiteboard correction, measuring the whiteboard 30 times at 5s interval)
Inter-instrument error	$\Delta E^*ab \leq 0.25$ (BCRA series II, average value of 12 color plates)	
Output	USB, Bluetooth	
Light source lifetime	10 years, more than 1 million times measurements	
Battery	3.7V/3000mAh, rechargeable 8000 times continuous tests	
Dimension	95×129×231mm	
Weight	750g	

## STANDARD DELIVERY

Main unit	1 pc
White calibration cavity	1 pc
Measuring aperture	3 pcs
USB cable	1 pc
USB disk	1 pc
AC/DC adapter	1 pc

## COLORIMETER (BASIC TYPE) CODE 5700-LS35



- Conforms with CIE 15, CIE S 005, ISO 7724-1 and ISO 13655 standards
- 3.5-inch IPS display and capacity touch panel
- Contains multiple color cards and can match the closest color code quickly
- QC testing function, can set color difference threshold
- Able to store 1000 colors and 1000 color comparison
- 3.7V/4000mAh battery, 10000 continuous measurements



white calibration cavity  
(included)



### SPECIFICATION

<b>Illumination geometry</b>	D/8, specular component include (SCI)
<b>Illumination light source</b>	full spectrum LED light source
<b>Measurement conditions</b>	light source D65, field of view 10°
<b>Measuring time</b>	about 1s
<b>Color space</b>	CIE Lab, Luv, LCh, Yxy, CMYK, RGB, He
<b>Color difference formula</b>	$\Delta E^*ab$ , $\Delta E^*uv$ , $\Delta E^*94$ , $\Delta E^*cmc$ (2:1), $\Delta E^*cmc$ (1:1), $\Delta E^*00$
<b>Repeatability</b>	standard deviation $\Delta E^*ab$ is within 0.03 (measurement condition: the average value of 30 measurements on the whiteboard at an interval of 3s after calibration)
<b>Charging interface</b>	USB (type-C)
<b>Dimension</b>	86×63×158mm
<b>Weight</b>	245g

### STANDARD DELIVERY

<b>Main unit</b>	1 pc
<b>White calibration cavity</b>	1 pc
<b>USB cable</b>	1 pc
<b>AC/DC adapter</b>	1 pc
<b>Cleaning cloth</b>	1 pc
<b>Locating plate</b>	1 pc

## ELECTROMAGNETIC ULTRASONIC THICKNESS GAGE CODE EMU-S340

- No surface polishing required, can penetrate anti-corrosion coating and rust (maximum 4mm), no coupling agent required
- Normal temperature permanent magnetic probe and high temperature permanent magnetic probe are using weak permanent magnet, to replace the strong permanent magnet commonly used nowadays. Completely solve the problem that EMAT transducer suction force is too large and difficult to move, so that the manual inspection is more simple, convenient and safe
- Temperature compensation function, can input the actual temperature of high-temperature components to automatically compensate the speed of sound, making the thickness measurement value more accurate
- Measurement of non verticality up to  $\pm 25^\circ$ , low verticality requirements for probe placement
- Scanning mode: A-scan format, B-scan image format display of thickness measurement values
- 50000 thickness values and 4000 A-scan or B-scan data can be stored
- Integrated high-brightness LEDs on the back for easy on-site illumination



transducer  
EMU-S50  
(included)

USB port



high temperature  
permanent magnetic probe  
EMU-S51 (optional)



normal temperature permanent  
magnetic probe sweep support  
EMU-S52 (optional)

### SPECIFICATION

<b>Measuring range</b>	1.5~200mm (steel, stainless steel)
<b>Resolution</b>	0.02mm
<b>Accuracy</b>	$\pm 0.04\text{mm} + H/1000$ ( $H \leq 50\text{mm}$ ) $\pm 0.2\text{mm}$ ( $50 \geq H \geq 100\text{mm}$ ) $\pm 0.3\text{mm}$ ( $100 \geq H \geq 200\text{mm}$ )
<b>Working gap (the distance between the probe and the measured object)</b>	normal temperature permanent magnetic probe $\leq 4\text{mm}$ high temperature permanent magnetic probe $\leq 2\text{mm}$
<b>Minimum required diameter</b>	$\geq 8\text{mm}$
<b>Non-perpendicularity</b>	$\pm 25^\circ$
<b>Excitation frequency</b>	3.0MHz~3.9MHz
<b>Material velocity</b>	1000~9999m/s
<b>Adjustment increments</b>	1m/s
<b>Gate function</b>	automatic gate, manual single gate, manual double gate
<b>Display</b>	color LCD, 3.5 inch/320×480 pixel
<b>Interface</b>	USB2.0
<b>Power supply</b>	rechargeable lithium battery, working time $\geq 8$ hours
<b>Dimension</b>	195×90×40mm
<b>Weight</b>	820g

### STANDARD DELIVERY

<b>Main unit</b>	1 pc
<b>Transducer EMU-S50</b>	1 pc
<b>Calibration block (diameter <math>\varnothing 36 \times</math> wall thickness 10mm)</b>	1 pc
<b>4G USB flash disk</b>	1 pc
<b>USB cable</b>	1 pc

### OPTIONAL ACCESSORY

<b>High temperature permanent magnetic probe</b>	EMU-S51
<b>Normal temperature permanent magnetic probe sweep support</b>	EMU-S52

### SPECIFICATION OF TRANSDUCERS

Code	Magnetism	Magnetic force	Diameter ( $\varnothing d$ )	Applicable temperature	Application
EMU-S50 (included)	weak permanent magnet	$\leq 15\text{N}$	$\varnothing 30\text{mm}$	-10~60°C	general use
EMU-S51 (optional)	weak permanent magnet	$\leq 20\text{N}$	$\varnothing 45\text{mm}$	-50~800°C	for high temperature

# ULTRASONIC THICKNESS GAGE CODE ISU-720D



- DATA OUTPUT
- WITH A AND B SCAN
- PENETRATE NON-METALLIC COATING AND MEASURE THE THICKNESS OF METAL SUBSTRATES

- Two measuring modes, Echo-Echo (E-E) and Transmit-Echo (T-E):
  - E-E is applicable for non-metallic coating (such as paint, plastic resin, etc.) on metal substrates, can penetrate coating and measure the thickness of substrates
  - T-E is to measure the thickness of material without coating, such as metal, plastic, glass, nylon, resin, ceramics, ice, etc.
- A scan, through the waveform, judges whether there are impurities, pores, cracks and so on inside, in order to avoid wrong measurement
- B scan, measures continuously, displays the thickness change on the screen
- Transducers can be automatically identified and zeroed
- Memory 10000 measurement values
- Data can be input to Excel and Word as keyboard signal
- Automatic or manual measurement
- When transducers are removed from workpieces, the measurement data are held on screen for easy viewing
- Set upper and lower limits for alarm when out-of-tolerance
- Automatic power off



### SPECIFICATION (ON STEEL)

Measuring range	refer to specification of transducers
Resolution	0.1/0.01mm
Accuracy	±0.04mm (H<10mm) ±(0.04+H/1000)mm (10≤H<100mm) ±H/333mm (H≥100mm) H is the thickness to be measured in mm
Frequency	refer to specification of transducers
Display	320×240, color screen display
Velocity	1000~9999m/s
Measuring frequency	2 times/second and 10 times/second
Operation temperature of main unit	-20~50°C
Output	USB
Measuring unit	mm/inch
Power supply	2×1.5V AA batteries
Dimension	133×75×29mm
Weight	260g (including batteries)

### STANDARD DELIVERY

Main unit	1 pc
Bicrystal transducer ISU-T07	1 pc
Battery (AA)	2 pcs
Couplant	1 bottle
USB cable	1 pc

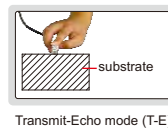
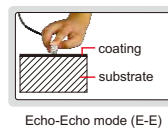

### OPTIONAL ACCESSORY

Transducer	ISU-T04, ISU-T06, ISU-T08, ISU-T12, ISU-T13, ISU-T25
Couplant (for ISU-T13)	ISU-HT5-COUPPLANT

### SPECIFICATION OF TRANSDUCERS (ON STEEL)

Code	Mode	Frequency	Diameter (Ød)	Measuring range	Minimum size of pipes for measurement (diameter × wall thickness)	Applicable temperature	Application
ISU-T07 (included)	T-E E-E	5.0MHz	13.2mm	T-E mode: 1.5~200mm E-E mode: 3~25mm	T-E mode: Ø25×3mm	<60°C	general use
ISU-T04 (optional)	T-E	10.0MHz	6mm	0.7~20mm	Ø15×1mm	<60°C	for small tubes
ISU-T06 (optional)	T-E	7.5MHz	9mm	0.7~50mm	Ø15×1.2mm	<60°C	for thin workpieces
ISU-T08 (optional)	T-E	5.0MHz	11mm	0.8~300mm	Ø25×1.2mm	<60°C	general use
ISU-T12 (optional)	T-E	2.0MHz	17mm	2~400mm	Ø40×3mm	<60°C	for casting iron
ISU-T13 (optional)	T-E	5.0MHz	15mm	3~100mm	Ø25×2mm	<350°C	for high temperature
ISU-T25 (optional)	T-E	1.0MHz	26mm	3~200mm	-	<60°C	for fiberglass and organic material



## ULTRASONIC THICKNESS GAGE CODE ISU-250C

INSPECTION  
CERTIFICATE

DATA  
OUTPUT



- Measure the thickness from one side of objects, suitable for pipes, tanks, etc.
- Applicable material: metal, plastic, glass, nylon, resin, ceramic, ice
- Tolerance measurement
- Average calculation of maximum 9 readings
- Data can be input to Excel and Word as keyboard signal

### SPECIFICATION (ON STEEL)

Measuring range	refer to specification of transducers
Resolution	0.1/0.01mm
Accuracy	±0.04mm (H<10mm) ±(0.04+H/1000)mm (10≤H<100mm) ±H/333mm (H≥100mm) H is the thickness to be measured in mm
Velocity	1000-9999m/s
Operation temperature of main unit	-20~50°C
Output	USB
Measuring unit	mm/inch
Power supply	2×1.5V AAA batteries
Dimension	64×116×27mm
Weight	220g



### STANDARD DELIVERY

Main unit	1 pc
Transducer ISU-T08	1 pc
Battery (AAA)	2 pcs
Couplant (for ISU-T04, ISU-T06, ISU-T08, ISU-T12)	1 bottle
USB cable	1 pc

### OPTIONAL ACCESSORY

Transducer	ISU-T04, ISU-T06, ISU-T12, ISU-T13
Couplant (for ISU-T13)	ISU-HT5-COUPPLANT

### SPECIFICATION OF TRANSDUCERS (ON STEEL)

Code	Frequency	Diameter (Ød)	Measuring range	Minimum size of pipes for measurement (diameter × wall thickness)	Applicable temperature	Application
ISU-T08 (included)	5.0MHz	11mm	0.8~300mm	Ø25×1.2mm	-20~60°C	general use
ISU-T04 (optional)	10.0MHz	6mm	0.7~20mm	Ø15×1mm	-20~60°C	for small tubes
ISU-T06 (optional)	7.5MHz	9mm	0.7~50mm	Ø15×1.2mm	-20~60°C	for thin workpieces
ISU-T12 (optional)	2.0MHz	17mm	2~400mm	Ø40×3mm	-20~60°C	for casting iron
ISU-T13 (optional)	5.0MHz	15mm	3~100mm	Ø25×2mm	0~350°C	for high temperature

## ULTRASONIC THICKNESS GAGE (BASIC TYPE) CODE ISU-100D

ATTENTION: NOT SUITABLE FOR CASTINGS AND ALUMINUM WORKPIECES

INSPECTION  
CERTIFICATE

POPULAR  
MODEL



- Measure the thickness from one side of objects, suitable for pipes, tanks, etc.
- Applicable material: steel, stainless steel, glass, copper, brass, polystyrene, titanium, etc.

### SPECIFICATION (ON STEEL)

Measuring range	0.8~300mm	
Resolution	0.1/0.01mm	
Accuracy	±0.05mm (H<10mm) ±(0.05+H/1000)mm (10≤H<100mm) ±H/333mm (H≥100mm) H is the thickness to be measured in mm	
Transducer	frequency	5MHz
	diameter (Ød)	10.8mm
Minimum size of pipes	20×1.2mm (diameter×wall thickness)	
Velocity	1000-9999m/s	
Operation temperature	main unit: -20~50°C transducer: -20~60°C	
Measuring unit	mm/inch	
Power supply	2×AAA batteries	
Dimension	114×64×28mm	
Weight	200g	

### STANDARD DELIVERY

Main unit	1 pc
Transducer	1 pc
Couplant	1 bottle
Battery (AAA)	2 pcs



## CONTACT/NON-CONTACT TACHOMETER CODE 9225-405

- 2 measuring methods, contact and non-contact
- Can measure rotary speed and line speed
- Automatically save the maximum value, minimum value and the last value, 500 data can be stored during continuous measurement
- Automatic power off



cone cavity head (included)



small cone head (included)



wheel with 0.1m perimeter (included)



cone head (included)



clamping sleeve (included)



reflection sticker (included)



### SPECIFICATION

Measuring method		non-contact	contact
Measuring range	rotary speed	2.5~99999RPM	0.5~19999RPM
	line speed	—	0.05~500m/min
Resolution	rotary speed	0.1RPM (range 2.5~999.9RPM) 1RPM (range 1000~99999RPM)	0.1RPM (range 0.5~999.9RPM) 1RPM (range 1000~19999RPM)
	line speed	—	0.01m/min (range 0.05~99.99m/min) 0.1m/min (range 100~500m/min)
Accuracy	rotary speed	$\pm(0.05\%n+1d)$ RPM n is rotary speed, d is resolution	$\pm(0.4\%n+1d)$ RPM (n<300RPM) $\pm(0.05\%n+1d)$ RPM (n≥300RPM) n is rotary speed, d is resolution
	line speed	—	$\pm(1\%+1d)$ m/min d is resolution
Laser power		class 3R, 3mW~4mW	—
Sampling time		0.6s (above 100RPM)	
Measuring distance		50~500mm	—
Operation temperature		0~40°C	
Power supply		3×AA batteries	
Dimension		206×71×36mm	
Weight		170g	

### STANDARD DELIVERY

Main unit	1 pc
Reflection sticker	3 pcs
Wheel with 0.1m perimeter	1 pc
Clamping sleeve	1 pc
Cone head	1 pc
Small cone head	1 pc
Cone cavity head	1 pc
Battery (AA)	3 pcs

## NON-CONTACT TACHOMETER CODE 9223-120

- Accurately measure the rotary speed without contact
- Automatically save the maximum value, minimum value and the last value, 500 data can be stored during continuous measurement

### SPECIFICATION

Measuring range	2.5~99999RPM
Resolution	0.1RPM (range 2.5~999.9RPM) 1RPM (range 1000~99999RPM)
Accuracy	$\pm(0.05\%n+1d)$ RPM n is rotary speed, d is resolution
Laser power	class 3R, 3mW~4mW
Sampling time	0.6 second (above 100RPM)
Measuring distance	50~500mm
Operation temperature	0~40°C
Power supply	3×AA batteries
Dimension	180×71×29.9mm
Weight	145g



reflection sticker (included)

### STANDARD DELIVERY

Main unit	1 pc
Reflection sticker	3 pcs
Battery (AA)	3 pcs

## CONTACT TACHOMETER CODE 9224-213

- Can measure rotary speed, line speed and line length
- Automatically save the maximum value, minimum value and the last value, 96 data can be stored during continuous measurement
- With backlight display



wheel with 0.1m perimeter (included)



clamping sleeve (included)



cone cavity head (included)



cone head (included)



small cone head (included)

### SPECIFICATION

Measuring range	rotary speed	0.5~19999RPM
	line speed	0.05~500m/min
	line length	0.05~99999m
Resolution	rotary speed	0.1RPM (range 0.5~999.9RPM) 1RPM (range 1000~19999RPM)
	line speed	0.01m/min (range 0.05~99.99m/min) 0.1m/min (range 100~500m/min)
	line length	0.02m
Accuracy	rotary speed	$\pm(0.4\%n+1d)$ RPM ( $n<300$ RPM) $\pm(0.05\%n+1d)$ RPM ( $n\geq 300$ RPM) n is rotary speed, d is resolution
	line speed	$\pm(1\%+1d)$ m/min d is resolution
	line length	$\pm(1\%+1d)$ m d is resolution
Sampling time	0.8s (above 60RPM)	
Operation temperature	0~40°C	
Power supply	3×AA batteries	
Dimension	171×71×35mm	
Weight	162g	

### STANDARD DELIVERY

Main unit	1 pc
Wheel with 0.1m perimeter	1 pc
Clamping sleeve	1 pc
Cone head	1 pc
Small cone head	1 pc
Cone cavity head	1 pc
Battery (AA)	3 pcs

## VIBRATION PEN (THREE PARAMETERS) CODE 0020-A199



- Acceleration, velocity and displacement can be tested
- Automatic power off

### STANDARD DELIVERY

Main unit	1 pc
LR44 battery	2 pcs

### SPECIFICATION

Parameter	acceleration	velocity	displacement
Measuring range	0.01~199.9m/s <sup>2</sup> (peak value)	0.01~199.9mm/s (virtual value)	0.001~1.999mm (peak-peak value)
Frequency	10Hz~1kHz	10Hz~1kHz	10Hz~500Hz
Frequency response	$\pm 5\%$ ( $\geq 20$ Hz) $-20\% \sim +10\%$ ( $< 20$ Hz)		
Linearity	$\pm(5\%+2\text{unit})$		
Indeterminacy of sensitivity	$\leq 3\%$		
Operation temperature	0°C~40°C/32°F~104°F		
Operation humidity	<85%		
Power supply	2×LR44 battery (for 10 hours working)		
Dimension	150x22x18mm		
Weight	55g		

## VIBRATION PEN CODE 9720-199



- Measure vibration of motors, fans, pumps, compressors and machine tools to prevent mechanical failure
- Small size, light weight, low energy consumption, easy operation, easy to carry
- One key control
- Automatic power off



### STANDARD DELIVERY

Main unit	1 pc
LR44 battery	2 pcs

### SPECIFICATION

Measured parameter	speed
Measuring range	0.1~199.9mm/s
Frequency	10Hz~1KHz
Accuracy	$\pm(5\% \pm 2)$ mm/s
Operation temperature	0°C~40°C
Operation humidity	<85%
Power supply	2×LR44 batteries (for 10 hours working)
Dimension	150x22x18mm
Weight	55g

## VIBRATION METER CODE 0022-VM20



software (included), monitor and collect data to PC software via USB cable, data can sent to Excel



### STANDARD DELIVERY

Main unit	1 pc
Software	1 pc
Accelerometer (including cable)	1 pc
Magnetic base	1 pc
M5 screw	1 pc
Battery (AAA)	4 pcs
AC/DC adapter	1 pc

- Can measure vibration frequency
- Can measure virtual value/peak value/peak-peak value of acceleration, velocity and displacement
- Suitable for factory inspection, status monitoring and fault diagnosis of mechanical equipments such as motors, pumps, fans, household appliances, compressors, smoke machines, generators, gearboxes, etc.
- Software is included: on-line monitoring, data storage



### SPECIFICATION

Measuring parameter	acceleration (virtual/peak/peak-peak value) $a_{RMS,1}, a_{Peak,1}, a_{P-P,1}, a_{Peak}, a_{P-P}$	velocity (virtual/peak/peak-peak value) $V_{RMS,1}, V_{Peak,1}, V_{P-P,1}, V_{Peak}, V_{P-P}$	displacement (virtual/peak/peak-peak value) $d_{RMS,1}, d_{Peak,1}, d_{P-P,1}, d_{Peak}, d_{P-P}$
Measuring range	0.01~200m/s <sup>2</sup> (peak value)	0.1~200mm/s (virtual value)	0.01~2mm (peak-peak value)
Frequency range	10Hz~5kHz	10Hz~1kHz	10Hz~500Hz
Amplitude frequency reponse	±5%		
Amplitude linearity	±5%		
Frequency accuracy	±0.5%		
Cut-off frequency (second-order high-pass filtering)	8kHz sampling frequency: 3.16Hz、10.00Hz、31.60Hz、N/A (adjustable) 32kHz sampling frequency: 12.64Hz、40.00Hz、126.4Hz、N/A (adjustable)		
Display	1.96" 128×64 dot matrix OLED screen		
Language	Chinese, English, Portuguese		
Power	<80mA/5V		
Power supply	4×AAA batteries: 6.0V/1000mAh; AC/DC adapter: 5V/2A		
Operation condition	temperature: -10°C~50°C; humidity: 25%RH~90%RH, non-condensing; pressure: 65kPa~108kPa		
Dimension	172×69×26mm		
Weight	240g		

## LASER DISTANCE METERS

- High accuracy models
- Large display with backlight
- Unit: m, ft, in, ft+in
- Distance, area, volume and height measurement
- Continuos measuring mode to track maximum and minimum value
- Memory of 30 measurement values
- Automatic power off: laser 30s, main unit 180s

### STANDARD DELIVERY

Main unit	1 pc
Battery (AAA)	2 pcs



9561-50B

### SPECIFICATION

Code	9561-50B	9561-70B
Measuring range	0.2~50m	0.2~70m
Resolution	0.001m, 0.001ft, 1/16"	
Accuracy	±(3+D/20)mm D: measured distance, unit: m	
Laser type	red laser, 630~670nm, class II, <1mW	
Power supply	2×AAA batteries	
Dimension (L×W×H)	115×50×28mm	
Weight	95g	

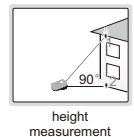
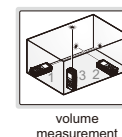
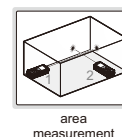
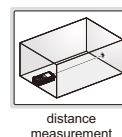

## PEN-TYPE CONDUCTIVITY/TDS/SALINITY TESTER CODE 0412-EB32

**IP67**  
WATERPROOF

- Can measure the conductivity, TDS and salinity
- Suitable for water quality testing, aquaculture, food processing, scientific research, etc.
- The same series of electrodes can be replaced with each other
- Automatic temperature compensation
- With the stabilizing and locking functions of the reading
- Can be used normally in any environment with the background light
- Auto power off
- Protection level: IP67
- Lightweight, easy to carry and operate

### SPECIFICATION

Measuring range	conductivity 0~200.0μS/cm, 0~2000μS/cm, 0~20.00mS/cm
	TDS 0~100.0ppm, 0~1000ppm, 0~10.00ppt
	salinity 0~10.00ppt
	temperature 0~50°C
Resolution	conductivity 0.1μS/cm, 1μS/cm, 0.01mS/cm
	TDS 0.1ppm, 1ppm, 0.01ppt
	salinity 0.01ppt
	temperature 0.1°C
Accuracy	conductivity ±1%FS
	temperature ±0.5°C
Calibration mode	1~3 points
Power supply	4×1.5V AAA batteries
Dimension	178×40×40mm
Weight	133g



IP67 waterproof



"platinum black needle"  
electrode (included)



electrodes can be replaced

### STANDARD DELIVERY

Main unit	1 pc
Standard solution	2 bottles
Test cup	2 pcs
1.5V AAA battery	4 pcs

## PORTABLE CONDUCTIVITY/TDS METER CODE 0411-0200

**IP65**  
WATERPROOF

- Reading mode: auto-read and continuous-read
- Automatic/manual temperature compensation
- Auto-hold feature senses and locks the measurement endpoint
- Cell constant is settable
- 1 point calibration with standard recognition
- Data capacity up to 200 sets for each parameter
- IP65 dust/waterproof
- Auto power off



wristband (included)



standard solution  
(included)

### SPECIFICATION

Conductivity	range	0.00μS/cm~200mS/cm
	resolution	0.01μS/cm minimum
	electronic unit accuracy	±1.0%FS
	measurement accuracy	±1.5%FS
	reference temperature	25°C/77°F
	calibration point	1
	standard recognition	84μS/cm, 1413μS/cm, 12.88mS/cm
TDS	range	0.00mg/L~300g/L
	resolution	0.01mg/L minimum
	accuracy	±1.0%FS
Temperature	range	-5~110°C/23~230°F
	resolution	0.1°C/0.2°F
	accuracy	±0.4°C/±0.7°F
Input	electrode with 5-pin aviation connector	
Power supply	rechargeable battery	
Dimension	80×225×35mm	
Weight	400g	

### STANDARD DELIVERY

Main unit	1 pc
Electrode	1 pc
Electrode holder	2 pcs
Wristband	1 pc
Silicone rubber case	1 pc
AC/DC adapter and charging cable	1 pc
Standard solution	1 bottle

## PEN-TYPE pH TESTER CODE 0432-HB22

**IP67**  
WATERPROOF



- 3 types of pH electrodes: bulb type, plane type and puncture type
- Suitable for water quality testing, sewage treatment, food and cosmetics testing, agriculture and scientific research, etc.
- Can measure the ORP, the same series of electrodes can be replaced with each other
- Automatic temperature compensation
- Alarm function: the red backlight displays alarm mode
- With the stabilizing and locking functions of the reading
- Protection level: IP67
- Can be used normally in any environment with three colors of backlight
- Auto power off
- Lightweight, easy to carry and operate



pH "bulb type" electrode (included)



ORP "platinum needle" electrode (optional)

### SPECIFICATION

Measuring range	-2.00~16.00pH
	temperature 0~50°C
	ORP -1000mV~+1000mV
Resolution	0.01pH
	temperature 0.1°C
	ORP 1mV
Accuracy	±0.02pH
	temperature ±0.5°C
	ORP ±0.2%FS
Calibration mode	1~3 points
Standard solution	USA (pH buffers: 4.00, 7.00, 10.01) NIST (pH buffers: 4.01, 6.86, 9.18)
Power supply	4×1.5V AAA batteries
Dimension	178×40×40mm
Weight	133g

### STANDARD DELIVERY

Main unit	1 pc
Standard solution	3 bottles (USA)
Test cup	3 pcs
KCl powder	1 bottle
1.5V AAA battery	4 pcs

### OPTIONAL ACCESSORY

pH plane type electrode	0432-HB-F
pH puncture type electrode	0432-HB-P
ORP electrode	0432-HB-O

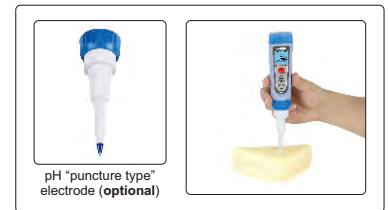

pH "puncture type" electrode (optional)



pH "plane type" electrode (optional)

## PORTABLE pH METER CODE 0431-0018

**IP65**  
WATERPROOF



- Reading mode: auto-read and continuous-read
- Automatic/manual temperature compensation
- Auto-hold feature senses and locks the measurement endpoint
- 1 or 2 points calibration with standard recognition
- Data capacity up to 200 sets for each parameter
- IP65 dust/waterproof
- Auto power off

### SPECIFICATION

pH	range	-2.00~18.00pH
	resolution	0.01pH
	electronic unit accuracy	±0.01pH
	measurement accuracy	±0.02pH
	calibration point	1 or 2
	standard recognition	NIST pH buffers: 4.01, 7.00, 10.01
Voltage	range	-1999~1999mV
	resolution	1mV
	accuracy	±0.1%FS
Temperature	range	-5~110°C/23~230°F
	resolution	0.1°C/0.2°F
	accuracy	±0.4°C/±0.7°F
Inputs	pH electrode: BNC (Q9) temp. probe: 4-pin aviation connector	
Power supply	rechargeable battery	
Dimension	80×225×35mm	
Weight	400g	



electrode holder

LCD with backlight

electrode holder

electrode



KCl powder (included)



wristband (included)



standard solution (included)

### STANDARD DELIVERY

Main unit	1 pc
Electrode	1 pc
Electrode holder	2 pcs
Wristband	1 pc
Silicone rubber case	1 pc
AC/DC adapter and charging cable	1 pc
Standard solution	3 bottles
KCl powder	1 bottle

### DIGITAL REFRACTOMETER CODE ISQ-DRM31

SUITABLE FOR WATER  
BASED COOLANT

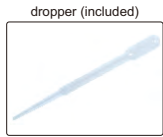

- Quickly measure the concentration of coolant, sugar solution, juice and drinks
- Two measurement modes: single measurement and automatic average multiple measurement
- Two units: brix and refractive index
- Refer to the refraction factor of coolant, for example: the refraction factor of grinding emulsion is 2.1, the reading value is 6%, so the actual concentration is  $(2.1 \times 6\%) = 12.6\%$
- Automatic power off



#### SPECIFICATION

Measuring range	0~50% (1.3330~1.4200RI)
Accuracy	±0.2% (±0.0003RI)
Resolution	0.1% (0.0001RI)
Power supply	1×AAA battery
Dimension	121×58×25mm
Weight	90g

#### STANDARD DELIVERY

Main unit	1 pc
Dropper	1 pc
Battery (AAA)	1 pc

### MINI DIGITAL REFRACTOMETER CODE 5801-A55

SUITABLE FOR WATER  
BASED COOLANT

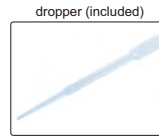

- Quickly measure the concentration of coolant
- Automatic temperature compensation
- Brix and refractive index can be displayed
- Refer to the refraction coefficient of coolant, for example: the refraction coefficient of grinding emulsion is 2.1, the reading value is 6%, so the actual concentration is  $(2.1 \times 6\%) = 12.6\%$
- Automatic power off

#### STANDARD DELIVERY

Main unit	1 pc
Dropper	1 pc

#### SPECIFICATION

Measuring range	0~50% (1.3330~1.4200RI)
Accuracy	±0.2% (±0.0003RI)
Resolution	0.1% (0.0001RI)
Power supply	built-in 3.7V rechargeable lithium battery
Dimension	147×46×27mm
Weight	115g (including battery)

### PORTABLE REFRACTOMETER CODE ISQ-RM30

SUITABLE FOR WATER  
BASED COOLANT

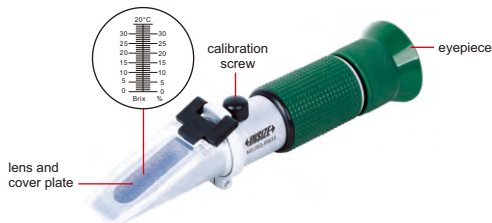

- Quickly measure the concentration of coolant
- Refer to the refraction factor of coolant, for example: the refraction factor of grinding emulsion is 2.1, the reading value is 6%, so the actual concentration is  $(2.1 \times 6\%) = 12.6\%$



#### SPECIFICATION

Measuring range	0~32%
Graduation	0.2%
Dimension	27×40×160mm
Weight	175g

### DIGITAL STOPWATCH CODE DSW-A010



- Split time, total time and continuous time can be displayed
- 10 groups of results can be read out from memory after resetting
- Scroll back and forth to read out the memory digits
- The fastest, slowest and average time can be displayed
- Able to record the split times (00-199)

#### SPECIFICATION

Measuring range	0~9 hours, 59 minutes, 59.99 seconds	
Resolution	0.01s	
Accuracy	±0.5s	
Function	memory	10 groups
	timer	up to 10 hours
	time	12-hour or 24-hour time display, alarm can be set
Power supply	LR44 battery	
Screen dimension	33.6×13.6mm	
Dimension	76×63×16mm (metal case)	

#### STANDARD DELIVERY

Main unit	1 pc
String	1 pc

### STROKE COUNTER CODE 7600-6

- Accumulate and record the number of mechanical movements
- Rotate back to zero



#### SPECIFICATION

Code	Number of digits	Range
7600-6	6	0-999999

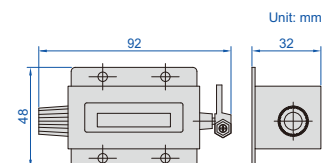

## DIGITAL MOISTURE METER CODE 9341-50



- Suitable for wood, smooth cement, hard gypsum, mixed mortar, brick, etc.
- Measure moisture, temperature and relative humidity
- Temperature type: ambient, dew point, wet bulb
- Maximum and minimum modes
- Automatic power off

### SPECIFICATION

Measuring depth	0~50mm	
Measuring range	moisture	0~60%
	temperature	-10~50°C/14~122°F
	relative humidity	0~100%RH
Accuracy	moisture	±2%
	temperature	±2%
	relative humidity	±5%RH
Resolution	moisture	0.1%
	temperature	0.1°C/0.1°F
	relative humidity	0.1%RH
Sampling time	0.5s for moisture	
	1s for temperature and relative humidity	
Power supply	2×AAA batteries	
Dimension	130×56×29mm	
Weight	206g	

### STANDARD DELIVERY

Main unit	1 pc
Battery (AAA)	2 pcs

## INDUCTIVE MOISTURE METER CODE 0120-IM24



- Suitable for wood, gypsum and cement
- MAX/MIN/HOLD mode
- Alarm function
- Low battery indication
- Auto power off

### SPECIFICATION

Measuring range	0~100%
Resolution	1%
Accuracy	±4%
Detection depth	20~40mm
Sampling time	0.5s
Battery	9V
Dimension	185×55×38mm
Weight	193g

### STANDARD DELIVERY

Main unit	1 pc
Battery	1 pc

## DIFFERENTIAL PRESSURE MANOMETER CODE 0140-DP05

- Offset and differential measurement
- Record maximum/minimum/average value with relative timestamp
- Built-in USB interface for data transmission
- Unit: psi, inH<sub>2</sub>O, bar, mbar, kPa, inHg, mmHg, oz/in<sup>2</sup>, ftH<sub>2</sub>O, cmH<sub>2</sub>O, kg/cm<sup>2</sup>
- Zero adjust
- Data hold
- Display with backlight
- Low battery indication
- Automatic power off
- Safety rating: CAT III 600V

software (included), connect to PC via USB cable

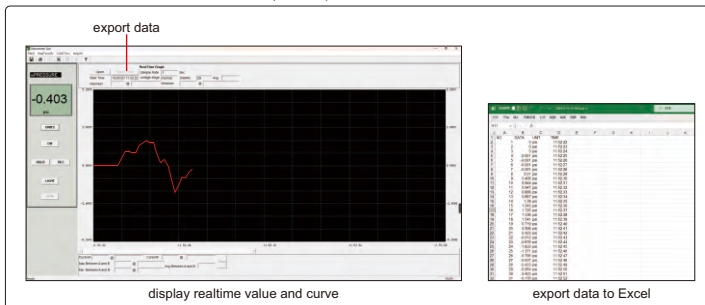

### SPECIFICATION

Pressure range	-5~5psi											
Maximum pressure	20psi											
Unit	psi	inH <sub>2</sub> O	bar	mbar	kPa	inHg	mmHg	oz/in <sup>2</sup>	ftH <sub>2</sub> O	cmH <sub>2</sub> O	kg/cm <sup>2</sup>	
Range	5	138.3	0.344	344.7	34.47	10.18	258.5	80	11.53	351.5	0.351	
Resolution	0.001	0.1	0.001	0.1	0.01	0.01	0.1	0.01	0.01	0.1	0.001	
Accuracy	±0.3%FSO (25°C)											
Repeatability	±0.2% (Max. ±0.5%FSO)											
Linearity/hysteresis	±0.29%FSO											
Response time	0.5s typical											
Operation temperature	0°C~50°C											
Power supply	1×9V 6F22 battery or AC/DC adapter											
Dimension (LxWxH)	165×90×40mm											
Weight	350g											

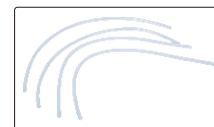

soft tubes (included)

### STANDARD DELIVERY

Main unit	1 pc
AC/DC adapter	1 pc
9V battery	1 pc
Software flash disk	1 pc
USB cable	1 pc
Soft tubes	4 pcs



## ANEMOMETER CODE 0110-1125

- Measure air velocity and temperature
- Min/Max, data hold function
- Bluetooth 4.0
- Auto power off
- Supplied with APP for Apple and Android

### SPECIFICATION

	Unit	Measuring range	Resolution	Accuracy
Air velocity	m/s	1.1~25.0	0.01	±(3%+0.3)
	km/h	4~90	0.1	±(3%+1)
	ft/min	220~4920	1	±(3%+40)
	MPH	2.5~56.0	0.1	±(3%+0.4)
	knots	2.2~48.0	0.1	
Air temperature	°C	0~50	0.1	±2
	°F	32~122	0.1	±4
Sensors	air velocity sensor, NTC-type precision thermistor			
Sampling time	0.5s			
Operation altitude	max 2000m			
Operation environment	0~50°C, 0~80%RH			
Storage environment	-10~60°C, 0~80%RH			
Auto power off	10 minutes			
Data port	Bluetooth 4.0			
Power supply	9V			
Dimension	213×54×36mm			
Weight	172g			

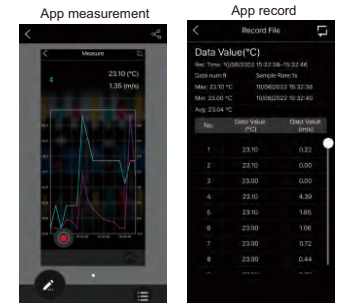

### STANDARD DELIVERY

Main unit	1 pc
Battery	1 pc

## BOURDON TUBE PRESSURE GAGES (LIQUID FILLED)

CAN BE  
CUSTOMIZED

- Stainless steel case and bezel, copper alloy internals
- Shock-proof and pulse-proof
- Suitable for pneumatic system, hydraulic system and compressed air system

Dial size	Ø63mm		
Process connection	1/4BSP	1/4ZG	1/4NPT
Connector location	bottom	bottom	bottom
Range (0~10bar/0~150psi)	5201-63B2Y10	5201-63Z2Y10	5201-63N2Y10



5201-63B2Y10

### SPECIFICATION

Accuracy class	1.6
Ambient temperature	-20~60°C
Medium temperature	≤60°C

## DIGITAL SOUND LEVEL METER (ADVANCED TYPE) CODE 9353-413

- Automatic range conversion
- Over range indicator
- Maximum mode
- Data hold
- AC signal output: 0.707Vrms, impedance approx.100Ω
- DC signal output: 20mV/dB, impedance approx.1kΩ



### SPECIFICATION

Measuring range	40dB~130dB (ref.20μPa)
Frequency	20Hz~12.5kHz
Resolution	0.1dB
Accuracy	IEC 61672-1:2013 Class 2
Frequency weighting	A weighting
Response time	fast (125ms), slow (1s)
Microphone	pre polarization condenser microphone
Reference direction	axial direction of condenser microphone
Power supply	4×1.5V AAA batteries
Dimension	210×68×27mm
Weight	240g

### STANDARD DELIVERY

Main unit	1 pc
Battery (AAA)	4 pcs
Screwdriver	1 pc

## SOUND LEVEL METER (BASIC TYPE) CODE 0010-A35

- Auto range selection
- Over range indication
- Display backlight
- Min/Max, data hold function
- Bluetooth 4.0
- Auto power off
- Supplied with APP for Apple and Android

### SPECIFICATION

Frequency	31.5Hz~8KHz
Measuring range	35dB~130dB
Accuracy	±3.0dB (ref 94dB@1kHz)
Resolution	0.1dB
Frequency weighting	A and C
Display update	2 times/sec
Microphone	1/2 inch electret condenser microphone
Power supply	9V battery
Operation temperature and humidity	0°C~40°C/32°F~104°F, 10%RH~90%RH
Dimensions	185×54×36mm
Weight	184g

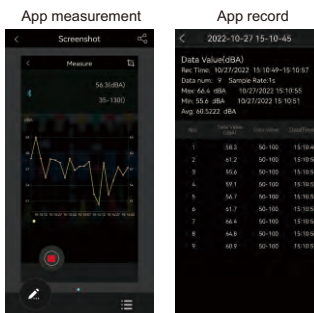

### STANDARD DELIVERY

Main unit	1 pc
Battery	1 pc
Windscreen	1 pc

## SOUND LEVEL METER (PROFESSIONAL TYPE) CODE 0011-FA25



- Integral function: 1s~24h (adjustable)
- Wide frequency range, large dynamic range, low background noise
- Parallel time weight and frequency weight
- Single range without shifting
- Software is included: on-line monitoring, data storage

### STANDARD DELIVERY

Main unit	1 pc
Software	1 pc
Windscreen	1 pc
Battery (AAA)	4 pcs
AC/DC adapter	1 pc

### SPECIFICATION

Accuracy	IEC 61672-1:2013 class 2
Microphone	1/2 inch prepolarized condenser microphone
Measuring range	25dB (A)~141dB (A); 35dB (C)~141dB (C); 50dB (Z)~141dB (Z) other frequency linear ranges: 31.5Hz: 26dB (A)~101dB (A); 12.5kHz: 25dB (A)~136dB (A)
Frequency	20Hz~12.5kHz
Self-generated electrical noise	<17dB (A), <23dB (C), <33dB (Z)
Frequency weighting	parallel A, C, Z weightings
Time weighting	parallel F (Fast), S (Slow), I (Impulse) weightings
Measuring function	Lp, Leq,t, Leq,T, Lmax, Lmin, Lpeak, SEL
Integral time	1s-24h (adjustable)
Start mode	button/clock/limit/interval
Power setting	power on or off regularly
Data storage	4MB FLash RAM 4 sets of parameter templates, 128 measurement point names; 64 calibration records
Language	Chinese, English, Portuguese
Power	<80mA/5V
Power supply	4×AAA batteries (for 10 hours working); AC/DC adapter: 5V/2A
Operation condition	temperature: -10°C~50°C; humidity: 25%RH~90%RH, non-condensing; pressure: 65kPa~108kPa
Dimension	230×69×26mm
Weight	180g



software (included), monitor and collect data to PC software via USB cable, data can sent to Excel

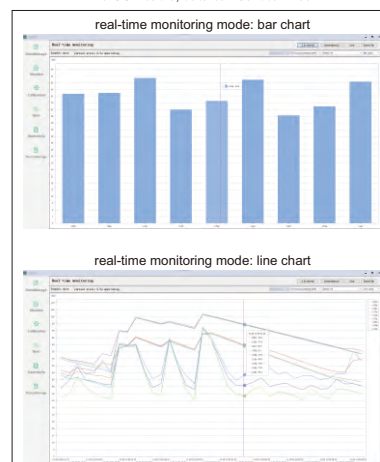

## LIGHT METER (BASIC TYPE) CODE 0130-L110

### SPECIFICATION

Measuring range	1~1999Lux	10~19990Lux	100~100000Lux
Resolution	1Lux	10Lux	100Lux
Accuracy	± (4%+10d), range<10000Lux ± (5%+10d), range≥10000Lux (d is resolution, calibrated with standard incandescent lamp at color temperature 2856K)		
Repeatability	±2%		
Sampling time	0.5s		
Operation environment	0~40°C, 0~70%RH		
Storage environment	-10~50°C, 0~80%RH		
Battery	9V		
Photodetector dimension	105×58×28mm		
Main unit dimension	130×72×30mm		
Weight	170g		



### STANDARD DELIVERY

Main unit	1 pc
Battery	1 pc

- Suitable for measuring illuminance in various occasions
- Data hold function
- Fast switching of measuring range, easy to operate

## LIGHT METER CODE 0131-A120

- Photosensor can rotate 90° clockwise and rotate 180° counterclockwise
- Build-in calibration filters ensure the accuracy when working in different colors
- Data hold function
- Lux/FC unit switch
- Low battery warning

### SPECIFICATION

Measuring range	0.1~199.9Lux	1~1999Lux	10~19990Lux	100~199900Lux
Resolution	0.1Lux	1Lux	10Lux	100Lux
Measuring range	0.01~19.99FC	0.1~199.9FC	1~1999FC	10~19990FC
Resolution	0.01FC	0.1FC	1FC	10FC
Accuracy	±(4%+10d), range<20000Lux/2000FC ±(5%+10d), range≥20000Lux/2000FC (d is resolution, calibrated with standard incandescent lamp at color temperature 2856K)			
Repeatability	±2%			
Sampling time	0.5s			
Operation environment	0~40°C, 0~70%RH			
Storage environment	-10~50°C, 0~80%RH			
Battery	9V			
Dimension	185×68×38mm			
Weight	130g			



### STANDARD DELIVERY

Main unit	1 pc
Battery	1 pc

## SINGLE GAS DETECTORS

**IP65**  
WATERPROOF



0611-SG01

- Detect combustible gas (EX, including CH<sub>4</sub>, C<sub>3</sub>H<sub>8</sub>, H<sub>2</sub>, etc), O<sub>2</sub>, CO or H<sub>2</sub>S, support more than 30 types of gas sensors, customization for detecting toxic gases (such as NO, NH<sub>3</sub>, PH<sub>3</sub>, etc) available
- Adjustable alarm level, alarm mode: sound, light, vibration
- Adjustable calibration level
- Sampling method: natural diffusion
- High concentration protection for sensor
- Up to 500 alarm records storage capacity
- Self-test on startup
- Display with backlight
- Language: English, Chinese
- Low battery indication
- Explosion proof level: Ex ib IIB T3 Gb



calibration cap (included)

### SPECIFICATION

Code	0611-SG01	0611-SG02	0611-SG03	0611-SG04
Gas	combustible gas/EX	O <sub>2</sub>	CO	H <sub>2</sub> S
Range	0-100%LEL	0-30%vol	0-1000ppm	0-100ppm
Resolution	1%LEL	0.1%vol	1ppm	1ppm
Accuracy	±5%FS			
Response time	T <sub>90</sub> <60s			
Operation environment	temperature: -10°C~55°C; humidity: <95%RH, no condensation			
Sensor lifetime	2 years (depending on working environment)			
Power supply	3.7V rechargeable Li-ion battery, working time>8h			
Dimension (LxWxH)	124×60×46mm			
Weight	205g			

### STANDARD DELIVERY

Main unit	1 pc
Calibration cap	1 pc
AC/DC adapter and charging cable	1 pc

## MULTI GAS DETECTOR CODE 0612-MG04

DATA  
OUTPUT

IP66  
WATERPROOF

- Detect combustible gas (EX, including CH<sub>4</sub>, C<sub>2</sub>H<sub>6</sub>, H<sub>2</sub>, etc), oxygen (O<sub>2</sub>), carbon monoxide (CO) and hydrogen sulfide (H<sub>2</sub>S), optional configuration includes other toxic gases such as NO, NH<sub>3</sub>, PH<sub>3</sub>, etc; support more than 30 types of gas sensors, flexible sensor combination and customization available
- Adjustable alarm level, alarm mode: sound, light, vibration and screen display
- Adjustable calibration level
- Sampling method: natural diffusion
- High concentration protection for sensor
- Data transmission via charging interface
- Up to 1000 alarm records storage capacity
- Self-test on startup
- Display with backlight
- Language: English, Chinese and Spanish (Portuguese and Russian customizable)
- Low battery indication
- Explosion proof level: Ex ib IIC T4 Gb



charging and data transmission interface on the back



software flash disk (included)



charging cable (included)



calibration cap (included)

software (included), connect to PC via USB cable, display test data and export record

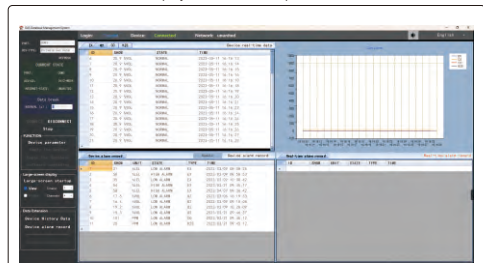

display real-time data and alarm record

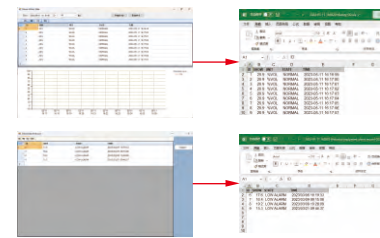

export history data and alarm record

### SPECIFICATION

Gas	combustible gas (EX)	O <sub>2</sub>	CO	H <sub>2</sub> S
Range	0-100%LEL	0-30%vol	0-1000ppm	0-100ppm
Resolution	1%LEL	0.1%vol	1ppm	1ppm
Accuracy	±5%FS			
Response time	T <sub>90</sub> <60s			
Operation environment	temperature: -10°C~50°C; humidity: <95%RH, no condensation			
Sensor lifetime	2 years (depending on working environment)			
Power supply	3.7V rechargeable Li-ion battery, working time>8h			
Dimension (LxWxH)	150×72×48mm			
Weight	310g			

### STANDARD DELIVERY

Main unit	1 pc
Calibration cap	1 pc
Software and USB cable	1 pc
AC/DC adapter	1 pc



VIDEO

## TESLAMETERS (GAUSSMETERS)

- Measure magnetic induction of DC magnetic field
- Directly display the N/S polarity of the measured magnetic field
- One-key zero function: eliminate the influence of zero drift before measurement
- Maximum value hold: record the maximum value of the changing magnetic field
- Unit switch between mT or G (1mT=10G)
- Auto ranging
- Built-in USB interface for data transmission
- Display with backlight
- Auto power off

### SPECIFICATION

Code	0501-MA01	0501-MA05
Range	2000mT	
Resolution	0.01mT (0~200mT) 0.1mT (200~2000mT)	
Accuracy	±1.0%	±2.0% (≤1000mT) ±5.0% (1000mT~2000mT)
Temperature coefficient	±0.1%/K	
Zero drift	±0.5mT/h	
Interface	USB	
Power supply	3×1.5V AA batteries or USB	
Dimension (L×W×H)	165×90×40mm	
Weight	350g	

### STANDARD DELIVERY

Main unit	1 pc
Radial probe	1 pc
Battery (AA)	3 pcs



0501-MA01

radial probe (included)



magnetic shielding cavity (optional)

DATA  
OUTPUT



VIDEO

### OPTIONAL ACCESSORY

Axial probe	0501-PA
Magnetic shielding cavity	0501-SHIELD



axial probe (optional)

## LASER BELT TENSION METER CODE 5900-HZ18

- Laser sensor, direct measurement, easy to use
- Two sensors: internal and external, external sensor is suitable for measurement in narrow spaces
- Automatic power off

### STANDARD DELIVERY

Main unit	1 pc
External sensor	1 pc

### SPECIFICATION

Measuring range	10~800Hz	
Input parameter range	maximum free belt length: 99.99m maximum belt weight: 9.999kg/m	
Accuracy	±5%	
Unit	N, lbf	
Measuring distance	3~20mm	
Operation temperature	10~50°C	
Power supply	4×1.5V AAA batteries	
Dimension	main unit	178×72×34mm
	external sensor	124×21×12mm
Weight	180g	



## LIGHT TRANSMITTANCE METER CODE 5804-LT21

- Suitable for light transmittance testing of various "regular transmission materials", such as building glasses, auto glasses, transparent films, plastic products, etc.
- With the design of parallel optical path of the light source and condensed light of the receiver, it can measure up to 100mm thickness
- Can measure the high transparent materials such as K9 glasses
- Two measuring modes, fixed base and handheld
- Conforming to CIE photopic luminosity function

### SPECIFICATION

Optical source	380nm~760nm, conforming to CIE photopic luminosity function
Measuring range	0.001%~99.8%
Accuracy	±1%
Resolution	0.001% (0%~10%), 0.01% (10%~100%)
Thickness to be measured	<100mm
Diameter to be measured	>10mm
Power supply	4×1.5V AAA batteries
Dimension	75×140×25mm
Weight	634g

### STANDARD DELIVERY

Main unit	1 pc
Transmitter	1 pcs (connect to main unit)
Receiver	1 pcs (connect to main unit)
Fixed base	1 pc
1.5V AAA battery	4 pcs

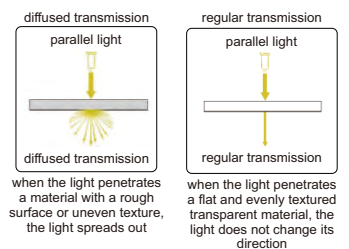
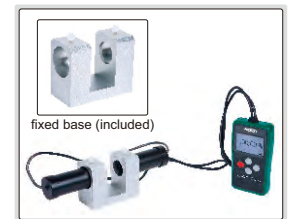

## DIGITAL GLASS THICKNESS METER CODE 5805-GT22

- Laser reflection principle to measure the thickness of glass and internal air layer. Especially suitable for building laminated glasses, hollow glass windows, etc.
- To test the thickness of single layer glasses, multi-layer glasses, two glasses with one cavity, three glasses with two cavities, laminated glasses, laminated insulating glasses, etc.

### SPECIFICATION

Measuring range	glass thickness (0~70mm), air layer (0~45mm)
Accuracy	±0.1mm (measuring range≤63mm), ±0.2mm (measuring range>63mm)
Resolution	0.01mm
Display	LCD
Power supply	4×1.5V AAA batteries
Dimension	130×72×33mm
Weight	330g



### STANDARD DELIVERY

Main unit	1 pc
Cross screwdriver	1 pc
1.5V AAA battery	4 pcs



## DC RESISTANCE TESTER CODE 9651-RM20

### STANDARD DELIVERY

Main unit	1 pc
RS232 communication cable	1 pc
Temperature probe	1 pc
Test clip	1 pc



- Maximum reading: 220000
- Basic accuracy: 0.05%
- 3.5 inch LCD screen
- Temperature compensation function
- Short-circuit zeroing calibration
- Bad contact detection
- Comparator: pass or fail judge
- Keyboard lock function

### SPECIFICATION

Function	Range	Resolution	Accuracy ("d" is the least reading)
Slow test	20mΩ	0.001mΩ	±(0.1%+3d)
	200mΩ/2Ω/20Ω/200Ω/ 2kΩ/20kΩ/200kΩ	0.001mΩ/0.00001Ω/0.0001Ω/0.001Ω/ 0.00001kΩ/0.0001kΩ/0.001kΩ	±(0.05%+2d)
	2MΩ	0.0001MΩ	±(0.1%+5d)
Medium test	20mΩ	0.001mΩ	±(0.2%+5d)
	200mΩ/2Ω/20Ω/200Ω/ 2kΩ/20kΩ/200kΩ	0.001mΩ/0.00001Ω/0.0001Ω/0.001Ω/ 0.00001kΩ/0.0001kΩ/0.001kΩ	±(0.1%+3d)
	2MΩ	0.0001MΩ	±(0.2%+5d)
Fast test	20mΩ	0.01mΩ	±(0.8%+5d)
	200mΩ/2Ω/20Ω/200Ω/ 2kΩ/20kΩ/200kΩ	0.01mΩ/0.0001Ω/0.001Ω/0.01Ω/ 0.0001kΩ/0.001kΩ/0.01kΩ	±(0.5%+5d)
	2MΩ	0.001MΩ	±(0.8%+5d)
Range mode	auto range, manual range and nominal range		
Test speed	slow: 3t/s, medium: 18t/s, fast: 60t/s		
Trigger	internal trigger, manual trigger, external trigger		
Interface	handler interface, RS232 interface, RS485 interface, USB interface and temperature compensation interface		
Power supply	AC: 100V~240V, 50Hz/60Hz		
Dimension (L×W×H)	307×264×107mm		
Weight	2.5kg		



temperature probe (included)



test clip (included)



RS232 communication cable (included)

## DC POWER SUPPLY CODE 9911-PS305



### SPECIFICATION

Voltage	range	30V
	setting resolution	10mV
	setting accuracy	≤.1%+20mV
	readback resolution	10mV
	readback accuracy	≤.1%+20mV
	load regulation	≤.1%+5mV
	line regulation	≤.01%+5mV
	ripple	10mVrms
Current	range	5A
	setting resolution	1mA
	setting accuracy	≤.2%+6mA
	readback resolution	1mA
	readback accuracy	≤.2%+6mA
	load regulation	≤.2%+3mA
	line regulation	≤.2%+3mA
ripple	8mArms	
OVP	0~33V	
OCP	0~5.5A	
Work condition	temperature: 0~40°C, humidity: ≤80%RH	
Storage condition	temperature: -20~60°C, humidity: ≤80%RH	
Cool system	fan cool	
Power supply	AC 220V±10%, 50Hz/60Hz	
Dimension (L×W×H)	230×80×150mm	
Weight	1.45kg	



- Four-digit LED display
- Output power display
- Output switch control
- 10mV/1mA high accuracy and resolution
- Panel locking function to prevent misoperation
- USB interface for power supply
- OVP/OCP protection
- 3 shortcut keys for presetting

### STANDARD DELIVERY

Main unit	1 pc
Test lead	2 pcs



test leads (included)

## PEN-TYPE DIGITAL MULTIMETER CODE 9241-ML200

- Auto/manual ranging
- Maximum mode
- Data hold
- NCV detection
- Low battery indication
- Auto power off
- Safety rating: CAT III 600V



test lead (included)



clips (included)

### SPECIFICATION

Function	Range	Resolution	Accuracy
DC Voltage	200mV/2V/20V/200V/600V	0.1mV/1mV/10mV/0.1V/1V	$\pm(0.7\%+2)$
	200mV/2V/20V/200V	0.1mV/1mV/10mV/0.1V	$\pm(0.8\%+3)$
AC Voltage	600V	1V	$\pm(1.0\%+3)$
	20mA/200mA	10 $\mu$ A/0.1mA	$\pm(1.5\%+3)$
DC Current	20mA/200mA	10 $\mu$ A/0.1mA	$\pm(2.0\%+3)$
Resistance	200 $\Omega$	0.1 $\Omega$	$\pm(1.0\%+3)$
	2k $\Omega$ /20k $\Omega$ /200k $\Omega$ /2M $\Omega$	1 $\Omega$ /10 $\Omega$ /0.1k $\Omega$ /1k $\Omega$	$\pm(1.0\%+1)$
	20M $\Omega$	10k $\Omega$	$\pm(1.0\%+5)$
Logic level test	<1.5V (green LED on) 1.5~3.5V (green & red LED off) >3.5V (red LED on)		
Diode	open circuit voltage 1.5V		
Continuity buzzer	<50 $\Omega$		
Power supply	2 $\times$ 1.5V AAA batteries		

### STANDARD DELIVERY

Main unit	1 pc
Test lead	1 pc
Clip	2 pcs
Battery (AAA)	2 pcs

## DIGITAL MULTIMETER CODE 9216-F520

### SPECIFICATION

Function	Range	Resolution	Accuracy ("d" is the least reading)
DC Voltage	200mV	0.1mV	$\pm(0.5\%+2d)$
	2V/20V/200V	0.001V/0.01V/0.1V	$\pm(1.0\%+2d)$
	600V	1V	$\pm(1.2\%+2d)$
AC Voltage (50~60Hz)	200mV	0.1mV	$\pm(1.5\%+30d)$
	2V	0.001V	$\pm(1.2\%+3d)$
	20V/200V	0.01V/0.1V	$\pm(1.5\%+3d)$
	600V	1V	$\pm(2.0\%+4d)$
DC Current	200 $\mu$ A	0.1 $\mu$ A	$\pm(1.0\%+3d)$
	2000 $\mu$ A/20mA/200mA	1 $\mu$ A/0.01mA/0.1mA	$\pm(1.5\%+3d)$
	10A	0.01A	$\pm(2.5\%+5d)$
AC Current (50~60Hz)	200 $\mu$ A	0.1 $\mu$ A	$\pm(1.5\%+5d)$
	2000 $\mu$ A/20mA/200mA	1 $\mu$ A/0.01mA/0.1mA	$\pm(1.8\%+5d)$
	10A	0.01A	$\pm(3.0\%+7d)$
Resistance	200 $\Omega$	0.1 $\Omega$	$\pm(1.2\%+4d)$
	2k $\Omega$	0.001k $\Omega$	$\pm(1.0\%+2d)$
	20k $\Omega$ /200k $\Omega$ /2M $\Omega$	0.01k $\Omega$ /0.1k $\Omega$ /0.001M $\Omega$	$\pm(1.2\%+2d)$
	20M $\Omega$	0.01M $\Omega$	$\pm(2.0\%+3d)$
Temperature (type-K)	-50 $^{\circ}$ C to 1000 $^{\circ}$ C	1 $^{\circ}$ C	$\pm(3.0\%+5^{\circ}$ C)
	-58 $^{\circ}$ F to 1832 $^{\circ}$ F	1 $^{\circ}$ F	$\pm(3.0\%+8^{\circ}$ F)
Diode test	test current: 0.3mA typical	1mV	$\pm(1.0\%+5d)$
Continuity check	less than 100 $\Omega$		
Power supply	9V battery		
Dimension (LxWxH)	150 $\times$ 70 $\times$ 48mm		
Weight	255g		



- 2000 counts digital display
- Auto ranging (except 200mV AC)
- Data hold
- Max hold
- Display with backlight
- Low battery indication
- Auto power off
- Safety rating: CAT III 600V



test leads (included)



temperature probe and adapter (included)

### STANDARD DELIVERY

Main unit	1 pc
Thermocouple adapter	1 pc
Temperature probe	1 pc
9V battery	1 pc
Test lead	2 pcs

## MINI DIGITAL MULTIMETER (BASIC TYPE) CODE 9242-ML100A

- Portable size with protective case
- 1999 counts digital display
- Data hold
- Display with backlight
- Low battery indication
- Auto power off
- Safety rating: CAT II 600V



POPULAR  
MODEL



### SPECIFICATION

Function	Range	Resolution	Accuracy ("d" is the least reading)
DC Voltage	200.0mV	0.1mV	$\pm(0.7\%+3d)$
	2000mV	1mV	$\pm(0.5\%+2d)$
	20.00V/200.0V/600V	0.01V/0.1V/1V	$\pm(0.7\%+3d)$
AC Voltage (40~400Hz)	200.0V/600V	0.1V/1V	$\pm(1.2\%+3d)$
DC Current	200.0 $\mu$ A/200.0mA	0.1 $\mu$ A/0.1mA	$\pm(1.0\%+2d)$
	10.00A	0.01A	$\pm(1.2\%+5d)$
Resistance	2000.0 $\Omega$	0.1 $\Omega$	$\pm(1.0\%+2d)$
	2000.0 $\Omega$ /20.00k $\Omega$ /200.0k $\Omega$	1 $\Omega$ /0.01k $\Omega$ /0.1k $\Omega$	$\pm(0.8\%+2d)$
	20.00M $\Omega$	0.01M $\Omega$	$\pm(1.2\%+3d)$
Battery test	1.5V/9V/12V battery check		
Diode test	open circuit voltage: 2.1V DC		
Continuity check	<50 $\Omega$		
Power supply	2 $\times$ 1.5V AAA batteries		
Dimension (LxWxH)	134 $\times$ 77 $\times$ 47mm		
Weight	206g		



test leads (included)

### STANDARD DELIVERY

Main unit	1 pc
Battery (AAA)	2 pcs
Test lead	2 pcs

## DIGITAL MULTIMETER (WITH JACK INDICATOR LIGHT) CODE 9246-180

- Jack indicator light: jacks flash green to indicate the corresponding jacks for test leads
- NCV detection and judge the strength by light and buzzer
- Self-calibration when power on to ensure accuracy
- LIVE firewire recognition
- Double color backlight (orange backlight prompts high voltage or current: the orange backlight automatically lights up when voltage is higher than 80V or the current is higher than 1A)
- Large range capacitance meter 100mF
- True RMS measurement
- Battery test function
- Max/Min mode
- Data hold
- Low battery indication
- Auto power off
- Safety rating: CAT III 1000V, CAT IV 600V



test leads (included)

### STANDARD DELIVERY

Main unit	1 pc
Test lead	2 pcs
Battery (AA)	2 pcs

### SPECIFICATION

Function	Range	Resolution	Accuracy
DC Voltage	600mV/6V/60V/600V/1000V	0.1mV/0.001V/0.01V/0.1V/1V	$\pm(0.5\%+3)$
AC Voltage	6V/60V/600V/750V	0.001V/0.01V/0.1V/1V	$\pm(0.8\%+5)$
DC Current	60 $\mu$ A/60mA/600mA/10A	0.01 $\mu$ A/0.01mA/0.1mA/0.01A	$\pm(1.2\%+3)$
AC Current	60mA/600mA/10A	0.01mA/0.1mA/0.01A	$\pm(1.5\%+3)$
Resistance	600 $\Omega$ /6k $\Omega$ /60k $\Omega$ /600k $\Omega$	0.1 $\Omega$ /0.001k $\Omega$ /0.01k $\Omega$ /0.1k $\Omega$	$\pm(1.0\%+3)$
	6M $\Omega$ /60M $\Omega$	0.001M $\Omega$ /0.01M $\Omega$	$\pm(1.5\%+3)$
Capacitance	10nF/100nF/1000nF/10 $\mu$ F/100 $\mu$ F/1000 $\mu$ F	0.001nF/0.01nF/0.1nF/0.001 $\mu$ F/0.01 $\mu$ F/0.1 $\mu$ F	$\pm(4.0\%+5)$
	10mF/100mF	0.001mF/0.01mF	$\pm(5.0\%+5)$
Frequency	10Hz/100Hz/1000Hz/10kHz/100kHz/1000kHz	0.001Hz/0.01Hz/0.1Hz/0.001kHz/0.01kHz/0.1kHz	$\pm(1.0\%+3)$
	10MHz	0.001MHz	$\pm(3.0\%+3)$
Duty cycle	1~99%	0.1%	$\pm(3.0\%+3)$
Diode measurement	forward DC current 2.5mA, reverse DC voltage 3.0V		
Continuity measurement	<30 $\Omega$		
Power	2 $\times$ 1.5V AA batteries		
Dimension (LxWxH)	188 $\times$ 88 $\times$ 50mm		
Weight	424g		



## SMART DIGITAL MULTIMETER CODE 9247-190

- Automatically identify test mode for AC voltage/DC voltage/resistance/continuity
- Non-connection AC voltage detection, and judge the strength by light and buzzer
- Self-calibration when power on to ensure accuracy
- LIVE firewire recognition
- Display with backlight
- True RMS measurement
- Data hold
- Low battery indication
- Auto power off
- Safety rating: CAT III 600V



test leads (included)

### STANDARD DELIVERY

Main unit	1 pc
Test lead	2 pcs
Battery (CR2032)	2 pcs

### SPECIFICATION

Function	Range	Resolution	Accuracy
DC Voltage	60mV/600mV/6V/60V/600V	0.01mV/0.1mV/0.001V/0.01V/0.1V	±(0.5%+3)
AC Voltage	60mV/600mV/6V/60V/600V	0.01mV/0.1mV/0.001V/0.01V/0.1V	±(1.0%+3)
DC Current	6000μA/60mA/600mA	1μA/0.01mA/0.1mA	±(1.2%+5)
AC Current	6000μA/60mA/600mA	1μA/0.01mA/0.1mA	±(1.5%+5)
Resistance	600Ω/6kΩ/60kΩ/600kΩ	0.1Ω/0.001kΩ/0.01kΩ/0.1kΩ	±(1.0%+5)
	6MΩ/60MΩ	0.001MΩ/0.01MΩ	±(1.5%+3)
Capacitance	6nF/60nF/600nF/6μF/60μF/600μF	0.001nF/0.01nF/0.1nF/0.001μF/0.01μF/0.1μF	±(4.0%+5)
	6mF/60mF	0.001mF/0.01mF	±(5.0%+5)
Frequency	10Hz/100Hz/1000Hz/10kHz/100kHz/1000kHz	0.001Hz/0.01Hz/0.1Hz/0.001kHz/0.01kHz/0.1kHz	±(1.0%+5)
	10MHz	0.001MHz	±(3.0%+5)
Duty cycle	1~99%	0.1%	±(3.0%+5)
Diode measurement	open circuit voltage 2.0V		
Continuity measurement	<50Ω		
Power	2×3V CR2032 batteries		
Dimension (LxWxH)	133×68×18mm		
Weight	178g		

## DIGITAL AC/DC CLAMP METER CODE 9315-CF210



test leads (included)



- 4000 counts display
- 28mm jaw opening
- NCV detection with light and sound alarm
- True RMS measurement
- Auto ranging
- REL (zero) function
- Data hold
- Polarity indication
- LCD screen with backlight
- Low battery indication
- Auto power off
- Safety rating: CAT III 300V/CAT II 600V



### SPECIFICATION

Function	Range	Resolution	Accuracy ("d" is the least reading)
DC Current	40.00A/400.0A	0.01A/0.1A	±(2.0%+5d)
AC Current *	40.00A/400.0A	0.01A/0.1A	±(2.0%+5d)
DC Voltage	400.0mV	0.1mV	±(0.7%+3d)
	4.000V/40.00V/400.0V/600V	0.001V/0.01V/0.1V/1V	±(0.5%+2d)
AC Voltage *	4.000V	0.001V	±(1.0%+5d)
	40.00V/400.0V/600V	0.01V/0.1V/1V	±(0.8%+5d)
AC Voltage frequency	10Hz~60kHz	0.01Hz~0.01kHz	±(0.5%+2d)
Resistance	400.0Ω	0.1Ω	±(1.0%+2d)
	4.000kΩ/40.00kΩ/400.0kΩ	0.001kΩ/0.01kΩ/0.1kΩ	±(0.8%+2d)
	4MΩ/40MΩ	0.001MΩ/0.01MΩ	±(2.5%+5d)
Capacitance	40.00nF/400.0nF/4.000μF/40.00μF/400.0μF	0.01nF/0.1nF/0.001μF/0.01μF/0.1μF	±(4.0%+5d)
	4.000mF/40.00mF	0.001mF/0.01mF	±10.0%
Frequency	10Hz~10MHz	0.01Hz~0.01MHz	±(0.1%+4d)
Duty cycle	0.1%~99.0%	0.1%	±(3.0%+5d)
Diode test	open circuit voltage: 4V		
Continuity check	<30Ω		
Power supply	2×1.5V AAA batteries		
Dimension (LxWxH)	215×75×37mm		
Weight	235g		

### STANDARD DELIVERY

Main unit	1 pc
Battery (AAA)	2 pcs
Test lead	2 pcs

\* AC voltage/current frequency response: 45Hz~400Hz, true RMS display

## BLUETOOTH DIGITAL MULTIMETER CODE 9219-KV220

- Built-in bluetooth
- Mobile app included
- 9999 counts digital display
- True RMS measurement
- Display with backlight
- Relative measurement mode
- Auto/manual ranging
- Auto power off
- Data hold
- NCV detection
- Low battery indication
- Safety rating: CAT III 600V



data acquisition app  
(included)

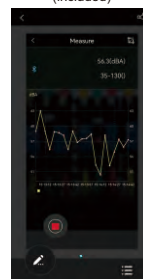

DATA  
OUTPUT



### SPECIFICATION

Function	Range	Resolution	Accuracy ("d" is the resolution)	
DC Voltage	9.999mV/99.99mV	0.001mV/0.01mV	±(0.7%+8d)	
	999.9mV/9.999V/99.99V/999.9V	0.1mV/0.001V/0.01V/0.1V	±(0.5%+3d)	
AC Voltage (40~400Hz)	9.999mV/99.99mV	0.001mV/0.01mV	±(1.0%+3d)	
	999.9mV/9.999V/99.99V/999.9V	0.1mV/0.001V/0.01V/0.1V	±(0.8%+3d)	
DC Current	999.9µA	0.1µA	±(0.8%+3d)	
	999.9mA/9.999A	0.1mA/0.001A	±(1.0%+3d)	
AC Current (40~400Hz)	999.9µA	0.1µA	±(1.0%+3d)	
	999.9mA/9.999A	0.1mA/0.001A	±(1.2%+3d)	
Resistance	999.9Ω/9.999kΩ/99.99kΩ/999.9kΩ	0.1Ω/0.001kΩ/0.01kΩ/0.1kΩ	±(0.8%+2d)	
	9.999MΩ	0.001MΩ	±(1.5%+3d)	
	99.99MΩ	0.01MΩ	±(2.0%+5d)	
Capacitance	9.999nF	0.001nF	±(4.0%+10d)	
	9.999nF/99.99nF/999.9nF/ 9.999µF/99.99µF/999.9µF	0.001nF/0.01nF/0.1nF/ 0.001µF/0.01µF/0.1µF	±(4.0%+5d)	
	9.999mF	0.001mF	±(10.0%)	
Frequency	99.99Hz~9.999MHz	0.01Hz~0.001MHz	±(0.1%+5d)	
Temperature	-40~1000°C	-40~0°C	1°C	±4°C
		>0~100°C	1°C	±(1.0%+5d)
		>100~1000°C	1°C	±(2.0%+5d)
	-40~1832°F	-40~32°F	1°F	±5°F
		>32~212°F	1°F	±(1.5%+5d)
>212~1832°F	1°F	±(2.5%+5d)		
Duty cycle	0.1%~99.9%	0.1%	±(3%+5d)	
Diode test	open circuit voltage 3.3V, test current 1.5mA			
Continuity check	<30Ω			
Power supply	3x1.5V AAA batteries			
Dimension (L×W×H)	187×88×56mm			
Weight	400g			



test leads (included)



temperature probe (included)

### STANDARD DELIVERY

Main unit	1 pc
Test lead	2 pcs
Temperature probe	1 pc
Battery (AAA)	3 pcs

## AC PHASE AND VOLTAGE DETECTOR CODE 9723-400

- Non-contact detection of phase sequence,  
high and low voltage, wire distinction
- Low battery indication
- Auto power off
- Flashlight

### SPECIFICATION

Phase sequence detection	screen display clockwise or counterclockwise
High and low voltage detection	beep: slow~fast backlight: green~red analog bar: low~high
Wire distinction	green backlight indicates neutral wire red backlight indicates live wire
Power supply	2×1.5V AAA batteries
Dimension	157×27×23mm
Weight	32g



### DIGITAL VOLTAGE TESTER CODE 9721-250



- Direct AC test (contact): 12-250V  
two way display: voltage displays on LCD screen and neon lamp lights up (when voltage>80V)
- Induction AC test (non-contact): 12-250V to detect power source or recognize the phase line, ground line and break point
- Direct DC test (contact): 6-36V instant sense and display
- Work without battery
- Tester tip: CRV material

#### SPECIFICATION

Range	AC: 12-250V; DC: 6-36V
Neon lamp life	30000 times
Dimension	133×21×19mm
Weight	22g

### VOLTAGE TESTER CODE 9722-250



- Tester tip: CRV material

#### SPECIFICATION

Range	AC: 100-250V
Neon lamp life	30000 times
Dimension	145×Ø15mm
Weight	21g

### INFRARED THERMAL IMAGING CAMERA (BASIC TYPE) CODE 9132-T400

NON-CONTACT  
TEMPERATURE MEASUREMENT



DATA  
OUTPUT

IP54  
WATERPROOF



front view



- IR/visible/laser indicator
- Trigger button for photo taking
- 2-meter drop test, IP54 protection

#### STANDARD DELIVERY

Main unit	1 pc
Power supply adapter	1 pc
TYPE-C cable	1 pc
16G TF card	1 pc

#### SPECIFICATION

IR image	IR resolution	120×90@17µm
	detector type	VOx/7.5~14µm
	frame rate	25Hz/9Hz
	thermal sensitivity/NETD	60mk
	focal length	2.28mm/F1.13
	field of view (FOV)	50°×38°
Visible camera	spatial resolution (IFOV)	7.6mrad
	focus	focus-free
Image display	visible camera resolution	320×240, focus-free
	flashlight	yes
Temperature measurement	display	2.4 inch IPS technology TFT display
	display resolution	320×240
	image model	IR/visible/picture-in-picture
	color palettes	6: white hot, iron red, hot iron, arctic, rainbow 1, rainbow 2
	temperature range	-20~150°C, 100~400°C (auto switching)
	accuracy	±2°C or ±2%, whichever is greater (target temp ≥0°C, ambient temp is 15~30°C)
	measurement spot	center spot
	measurement area	3 (incl. max & min temp)
	auto max & min spot tracking	yes
	alarm	full screen max & min spot alarm
Image storage	storage media	TF card (16G)
	IR image format	full radiometric (JPG) (120x90)
	visible image	yes, 320x240
Connections & communications	USB	type-C, TF card slot
	tripod interface	yes
	mobile APP	yes
	PC IR analysis software	yes
Power system	battery type	rechargeable li ion battery
	battery operation time	>5 hours
	charging time	internal charge, ≤2.5 hours
Environmental parameters	operation temperature	-10~50°C
	storage temperature	-40~70°C
	protection	IP54, 2-meter drop test
	certification	CE/ROHS/FCC
	dimension (LxWxH)	194×61.5×76mm
weight	350g	

## INFRARED THERMOMETER (BASIC TYPE) CODE 0222-C520

- Unit: °C, °F
- Automatic data hold
- MAX/MIN/AVG/DIF mode
- High and low alarm
- Adjustable emissivity
- Low battery display
- Over range indicator
- Automatic power off

### SPECIFICATION

Temperature range	-50°C~500°C/-58°F~932°F
Temperature accuracy	±(2°C+0.1°C/°C) (at -50°C~0°C), ±2.0°C or ±2% (at 0°C~500°C) ±(4°F+0.1°F/°F) (at -58°F~32°F), ±4.0°F or ±2% (at 32°F~932°F)
Temperature resolution	0.1°C/0.2°F
Distance to spot size (D:S)	12:1
Emissivity	0.10~1.00 (adjustable)
Repeatability	±0.5°C or ±0.5%; ±1.0°F or ±0.5%
Response time	≤500ms (95% of reading)
Spectral response	8μm~14μm
Diode laser	output<1mW, wavelength 630nm~670nm, class 2 laser product
Power supply	2×AAA batteries, working time≥6h
Automatic power off	about in 15 seconds
Operation environment	temperature: 0°C~50°C/32°F~122°F; humidity: <90%RH (non-condensing)
Storage environment	temperature: -20°C~60°C/-4°F~140°F; humidity: <90%RH (non-condensing)
Dimension	148×85×46mm
Weight	160g



### STANDARD DELIVERY

Main unit	1 pc
Battery (AAA)	2 pcs

## INFRARED THERMOMETER (STANDARD TYPE) CODE 0213-A500

- Unit: °C, °F
- Dual laser sighting
- Negativity display
- Automatic power off
- Automatic data hold
- Over range indicator
- Max/Min display

### SPECIFICATION

Temperature range	-20°C~380°C/-4°F~716°F
Temperature accuracy	±2.5°C (at -20°C~20°C), ±2% or ±2.0°C (at 20°C~380°C) ±4.5°F (at -4°F~68°F), ±2% or ±3.6°F (at 68°F~716°F)
Temperature resolution	0.1°C/0.1°F
Distance to spot size (D:S)	12:1
Emissivity	0.95 (fixed)
Repeatability	±1°C/1.8°F
Response time	150ms
Spectral response	8~14μm
Diode laser	output<1mW, wavelength 630~670nm class 2 laser product
Operation temperature	0°C~50°C/32°F~122°F
Operation humidity	10%RH~90%RH
Storage temperature	-10°C~60°C/14°F~140°F
Storage humidity	<80%RH
Power supply	1×9V battery
Dimension	137×73×38mm
Weight	135g



### STANDARD DELIVERY

Main unit	1 pc
Battery	1 pc

## INFRARED AND PENETRATION THERMOMETER CODE 0321-IT42

**IP65**  
WATERPROOF

- Can measure the surface and inside temperature of objects
- Low battery display
- Display backlight
- High and low alarm
- Automatic data hold (infrared system)
- Automatic power off (infrared system)
- Unit: °C/°F



### SPECIFICATION

Infrared system	temperature range	-15°C~280°C/5°F~536°F
	temperature resolution	0.1°C/0.1°F
	temperature accuracy	±3.0°C (at -15°C~20°C), other range ±(1%+1.0)°C ±5.4°F (at 5°F~68°F), other range ±(1%+1.8)°F
	distance to spot size (D:S)	4:1
	emissivity	0.95 (fixed)
	spectral response	8~14μm
Penetration system	temperature range	-40°C~200°C/-40°F~392°F
	temperature resolution	0.1°C/0.1°F
	temperature accuracy	±2.0°C (at -40°C~0°C), other range ±(1%+1.0)°C ±3.6°F (at -40°F~32°F), other range ±(1%+1.8)°F
Repeatability	<1.0°C	
Measurement response time	<500ms	
Power supply	2×1.5V AAA batteries	
Dimension	140×39×24mm	
Weight	140g	

### STANDARD DELIVERY

Main unit	1 pc
Battery (AAA)	2 pcs

## DIGITAL THERMOHYGROMETER (PROFESSIONAL TYPE) CODE 9362-TH27

**IP50**  
DUSTPROOF

- Measure humidity, ambient temperature and dew-point temperature
- Max/Min/Average mode
- Alarm function
- IP50 protection grade



### SPECIFICATION

Sensor model	NTC thermistor/humidity capacitance/ digital sensor
Temperature range	-20°C~70°C/-4°F~158°F
Temperature accuracy	±0.5°C/±0.9°F
Temperature resolution	0.1°C/0.2°F (minimum adjustable unit is 0.2°F in setting mode)
Humidity range	0~100%RH
Humidity accuracy	±5%RH
Humidity resolution	0.1%RH
Sampling interval	5s
Battery	1.5V AAA
Dimension	95×107×18mm
Weight	105g

### STANDARD DELIVERY

Main unit	1 pc
Battery (AAA)	1 pc

# DATA LOGGER FOR TEMPERATURE AND HUMIDITY (BUILT-IN SENSOR) CODE 0311-3070

DATA  
OUTPUT

IP54  
WATERPROOF



- Signal acquisition, display, storage, analysis function
- Low power consumption
- Built-in high-precision temperature and humidity sensor
- Software is included

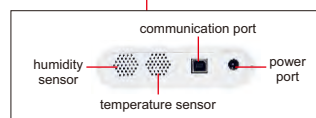

software (included), record and download data to PC software via USB cable

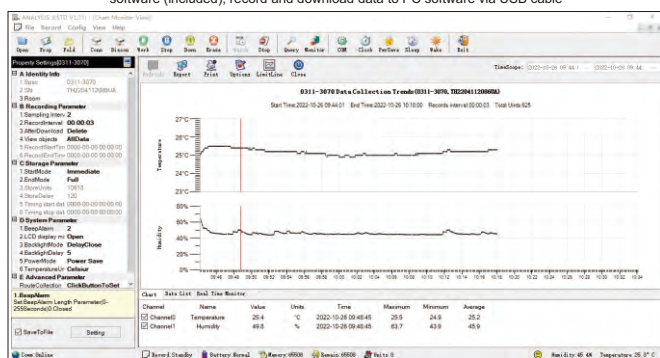

stand (included)

## SPECIFICATION

Temperature range	-30°C~70°C/-22°F~158°F
Temperature accuracy	±0.3°C (at 23°C±2°C), other range ±0.5°C ±0.6°F (at 73.4°F±3.6°F), other range ±0.9°F
Temperature resolution	0.1°C/0.2°F
Humidity range	0%RH~100%RH
Humidity accuracy	±3%RH (at 10%RH~85%RH), other range ±5%RH
Humidity resolution	0.1%RH
Memory capacity	10918
Alarm	function: alarm when over high or low limit method: display+buzz+backlight
Sampling interval	2s, 5s, 10s, 30s, 60s, 255s (adjustable)
Logging interval	2 seconds~24 hours (adjustable)
Start with delay	1~120 seconds (adjustable)
Start mode	start immediately/delay start/timing start
End mode	full/FIFO/preset/timing end
Timing start/end	random start/end with format YYMMDD HHMMSS
Interface	USB
Time battery	CR2032
Power supply	3.6V lithium battery (ER14505) or 5~24V DC
Dimensions	123×117×33mm
Weight	260g

## STANDARD DELIVERY

Main unit	1 pc
Software and USB cable	1 pc
Time battery	1 pc
Lithium battery	1 pc

## THERMOHYGROMETER CODE 0310-H26

### STANDARD DELIVERY

Main unit	1 pc
Battery	1 pc

### SPECIFICATION

Function	Measuring range	Resolution	Accuracy
Ambient temperature	0°C~50°C 32°F~122°F	0.1°C/0.1°F	±1.0°C/±1.8°F
Wet bulb temperature	0°C~50°C 32°F~122°F		
Dew point temperature	0°C~50°C 32°F~122°F		
Humidity	0%RH~80%RH	0.1%RH	±5.0%RH
Auto power off	30 minutes		
Data port	Bluetooth 4.0		
Power supply	9V battery		
Dimension	204×54×36mm		
Weight	172g		



- Measure humidity, ambient temperature, dew point temperature and wet bulb temperature
- Min/Max, data hold function
- Bluetooth 4.0
- Auto power off
- Supplied with APP for Apple and Android

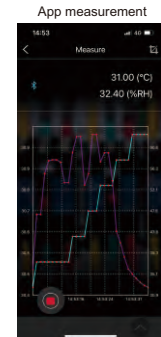

App record

No.	Date/Time	Data Value (°C)
1	30.00	41.40
2	30.00	38.50
3	30.00	38.50
4	31.00	35.50
5	31.00	34.20
6	31.00	33.40
7	31.00	32.80
8	31.00	32.40
9	31.00	32.50
10	31.00	32.00
11	31.00	31.70

## THERMOHYGROMETER (EXTERNAL SENSOR) CODE 0313-TH48



- External sensor, 3m cable
- Time/temperature/humidity display
- Temperature and humidity upper and lower limit alarm function
- Unit: °C/°F
- Low battery warning

### SPECIFICATION

Temperature range	-40°C~-80°C/-40°F~176°F
Temperature accuracy	±0.5°C (at -20°C~60°C), ±1.0°C (at 60°C~80°C), ±2°C (at -40°C~-20°C), ±2°F (at -20°F~176°F), ±3°F (at -40°F~-20°F)
Temperature resolution	0.1°C (at -20°C~80°C), other range 1°C 0.1°F (at -20°F~100°F), other range 1°F
Humidity range	0%RH~99.9%RH
Humidity accuracy	±5%RH (at 10°C~60°C), other range ±7% ±5%RH (at 50°F~140°F), other range ±7%
Humidity resolution	0.1%RH
Sensitivity attenuation value	temperature: <0.1°C/year (<0.2°F/year) humidity: <1%RH/year
Sampling interval	5 seconds
Power supply	built-in rechargeable lithium battery (USB 5V charging) working time at least one month
Dimension	88×88×21mm
Weight	174g

### STANDARD DELIVERY

Main unit	1 pc
USB charging cable	1 pc

## K-TYPE THERMOCOUPLE THERMOMETER (ECONOMIC TYPE) CODE 0320-K230



- Contact K-type thermocouple
- Unit: °C/°F
- Data hold function
- Low battery display
- Display backlight

### SPECIFICATION

Temperature range	-50°C~200°C/-58°F~392°F
Temperature accuracy	±2.0°C/±3.6°F
Temperature resolution	0.1°C (at -50°C~199.9°C), 1°C (at -50°C~200°C) 0.1°F (at -58°F~199.9°F), 1°F (at -58°F~392°F)
Sampling rate	2.5 times/sec
Power supply	3×3V CR2450 batteries (for 300 hours working)
Operation voltage	6.8V~10V
Dimension	149×76×34mm
Weight	220g

### STANDARD DELIVERY

Main unit	1 pc
Thermocouple (K-type)	1 pc
CR2450 battery	3 pcs

# ROUNDNESS MEASURING MACHINE CODE RCT-RA260

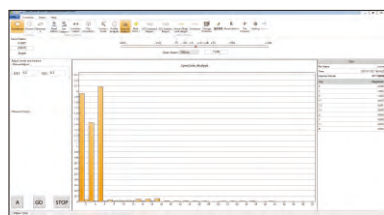

spectrum analysis

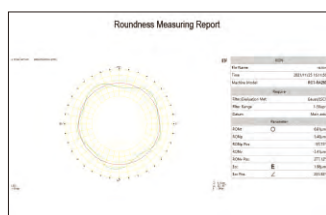

measurement

## SPECIFICATION

Probe	measuring range	±300µm
	resolution	0.001µm
	linear accuracy	0.25%
Ruby stylus	size	Ø2x10mm
	direction	two directions
	adjustable angle	±45°
X axis	travel	165mm
	excess range	25mm
	drive mode	by hand
Z axis	drive mode	motor
	travel	320mm
	movement speed	0.5~10mm/s
Rotary stage	rotation accuracy	(0.025+6H/10000)µm for H≤20mm, H is the measuring height in mm
	rotation speed	6rpm
	max. measuring diameter	260mm
	max. workpiece diameter (rotation diameter)	400mm
Rotary axis	radial rotation accuracy	±0.0125µm
	axial runout accuracy	±0.05µm
Adjustable 3D stage	diameter	180mm
	adjustment range of center	±3mm
	adjustment range of level	±2°
Granite stage	weight capacity	20kg
	external grip diameter	Ø1~Ø81mm
	internal grip diameter	Ø31~Ø70mm
Precision chuck	pressure range	0~0.8MPa
	oil mist removal accuracy	0.01µm
	export oil mist concentration	0.5mg/m³
Dimension (LxWxH)		1300×795×1715mm
Power supply		220±10%V, 50Hz
Power		500W
Weight		320kg

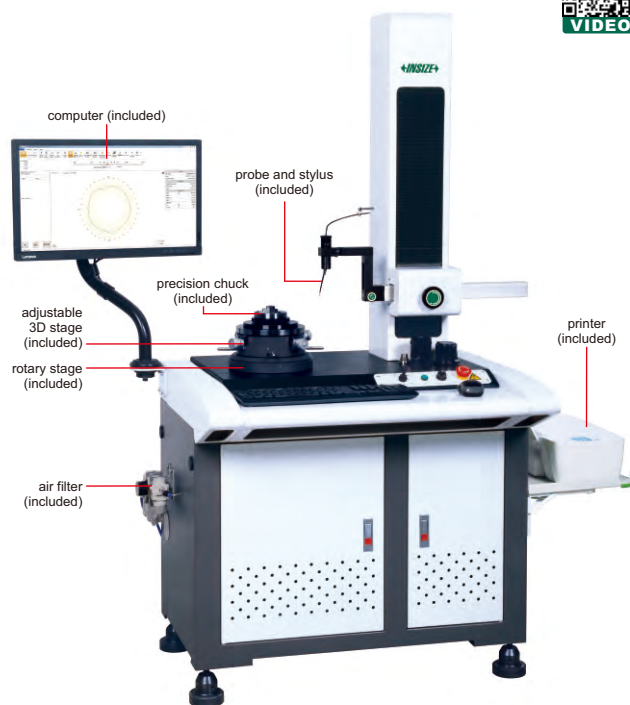

- Air-floating spindle
- Can measure roundness, coaxiality, concentricity, flatness, radial runout, axial runout, parallelism and perpendicularity.
- Spectrum analysis, automatic gap/burr removal, waveform analysis
- 4 roundness evaluation methods: smallest area method, least square method, smallest circumscribed circle method, largest inscribed circle method
- Measuring filter: 1-15µm, 1-50µm, 1-150µm, 1-250µm, 1-500µm, 15-100µm, 15-500µm, 2-15µm
- Filter form: Gauss (ISO standard)
- Software is included, for measurement, analysis, data output, etc.

## STANDARD DELIVERY

Main unit	1 pc
Probe (with ruby stylus)	1 pc each
Standard block	1 pc
Precision chuck	1 pc
Adjustable 3D stage	1 pc
Rotary stage	1 pc
Computer	1 pc
Software	1 set
Printer	1 pc
Air filter	1 set
Installation tools	1 set



standard block (included)

## OPTIONAL ACCESSORY

Probes	refer to details
Precision chucks	refer to details
Dryer	ISC-DRY

## SPECIFICATION OF PROBES

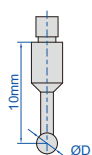

Code	Diameter (ØD)	Remark
RCT-RA260-T1	2mm	included
RCT-RA260-T2	0.5mm	optional
RCT-RA260-T3	1mm	optional
RCT-RA260-T4	4mm	optional
RCT-RA260-T5	8mm	optional

## SPECIFICATION OF PRECISION CHUCKS

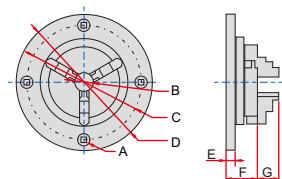

Code		A	B	C	D	E	F	G	Clamping range (mm)		Remark
									external grip dia.	internal grip dia.	
RCT-RA260-C1	M5x0.8	16	100	118	8	28	13		Ø0.8~63	Ø23~58	optional
RCT-RA260-C2	M6x1.0	20	116	143	10.5	37	15		Ø1~81	Ø31~70	included
RCT-RA260-C3	M6x1.0	26	140	168	10	39	19		Ø1~100	Ø36~90	optional



# SURFACE PROFILE MEASURING MACHINE CODE SPM-1000



- Software is included, for surface profile measurement and data output
- Probe compensation
- Output as format txt, csv, etc.
- Large range design, the leverage ratio is 1:2.2, maintain the original accuracy of the sensor
- The overall structure of the Z-axis sensor does not have any elastic components, ensuring the measuring force is constant regardless the position of probe

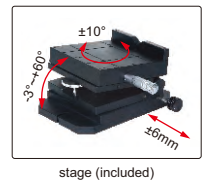
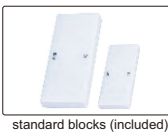
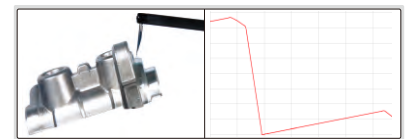
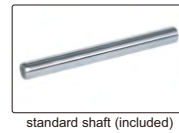
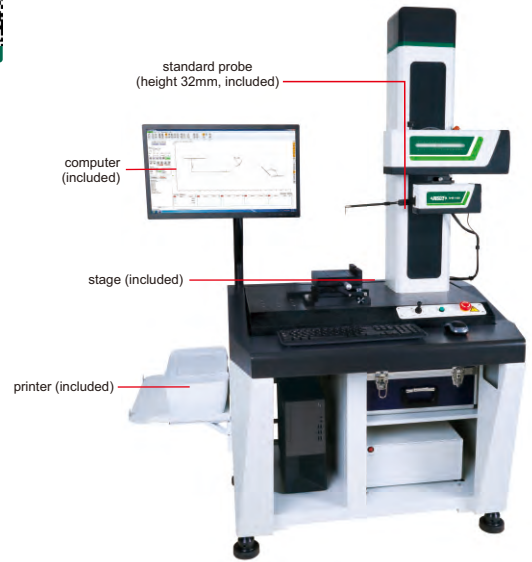
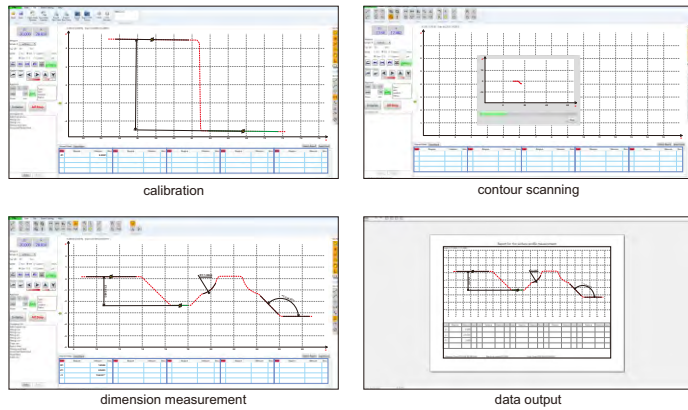

## SPECIFICATION

X axis measuring range	140mm
X axis resolution	0.2 $\mu$ m
X axis straightness	0.8 $\mu$ m/100mm
X axis moving speed	0.1~10mm/s
Z axis measuring range	$\pm 20$ mm
Z axis resolution	0.05 $\mu$ m
Z axis moving speed	0.5~10mm/s
Linear accuracy	$\pm(1.5+ 0.2H )\mu$ m, H is measuring height in mm
Angular measuring accuracy	$\pm 2'$
Arc measuring accuracy	$\pm(2+R/8)\mu$ m, R is 2~10mm standard ball
Radius of probe tip	25 $\mu$ m
Moving direction	backward
Measuring force	6.86~9.8mN
Measuring unit	mm/inch
Traceable angle	72° (upward), 87° (downward)
Drive mode	motor
Travel of Z axis	430mm
Dimension (L×W×H)	1200×700×1780mm
Power supply	220 $\pm 5\%$ V, 50Hz
Weight	320kg

## STANDARD DELIVERY

Main unit	1 pc
Standard probe and arm	1 pc of each
Standard block	2 pcs
Standard ball	2 pcs
Standard shaft	1 pc
Stage	1 pc
Vise	1 pc
Measuring arm	1 pc
Computer	1 pc
Measurement software	1 pc
Printer	1 pc
Installation tools	1 set

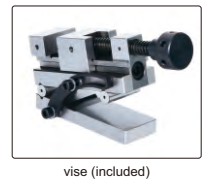

## OPTIONAL ACCESSORY

Probe	refer to details
-------	------------------

## SPECIFICATION OF PROFILE PROBES

Unit: mm

<p>chisel stylus</p> <p>code SPM-1000-T01 (H=32mm, included) code SPM-1000-T02 (H=48mm, optional) code SPM-1000-T03 (H=68mm, optional)</p>	<p>cone stylus</p> <p>code SPM-1000-Z01 (H=32mm, optional) code SPM-1000-Z02 (H=48mm, optional) code SPM-1000-Z03 (H=68mm, optional)</p>	<p>ball stylus</p> <p>code SPM-1000-R01 (H=32mm, optional) code SPM-1000-R02 (H=48mm, optional) code SPM-1000-R03 (H=68mm, optional)</p>	<p>standard arm, code SPM-1000-SP (included), stylus is not included</p>
<p>probe for small holes, code SPM-1000-SBP (optional), stylus is included</p> <p>measure the contour of holes with diameter &gt; Ø8mm</p>	<p>transverse probe, code SPM-1000-LP (optional), stylus is included</p> <p>measure the contour of holes in radial direction</p>		

# ROUGHNESS TESTER CODE ISR-C002

CAN BE OPERATED BY  
MOBILE PHONES OR COMPUTERS

BLUETOOTH

DATA  
OUTPUT

- Roughness tester can be operated by mobile phones (only Android system) or computers
- Data can be sent to Excel by connecting to computers via bluetooth or SPC cable
- Support bluetooth printer
- 21 roughness parameters
- Display roughness value, profile and curve
- Memory of maximum 100 results
- Automatic power off



software flash disk  
(included)

probe cover (included)



put the small workpieces  
directly under the  
probe for measurement

adjustable stand (included)



bluetooth printer (optional)



light duty test stand (optional)



the maximum workpiece  
height is 220mm

heavy duty test stand (optional)



the maximum workpiece  
height is 310mm

operate roughness tester by computers

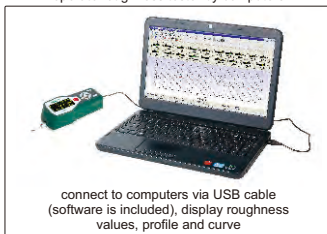

connect to computers via USB cable  
(software is included), display roughness  
values, profile and curve

operate roughness tester by mobile phones



connect to mobile phones via  
bluetooth (only Android system),  
display roughness values,  
profile and curve

Unit: mm

extension rod (optional), code ISR-C002-ER

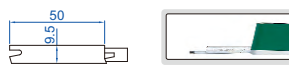

transverse rod (optional), code ISR-C002-TR



deep groove probe (optional), code ISR-C002-DGP

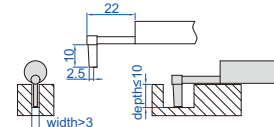

tiny hole probe (optional), code ISR-C002-SBP

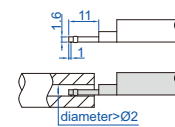

data can be sent to Excel by connecting to computer via bluetooth or SPC cable

via bluetooth



receiver  
(optional)

SPC cable  
(optional)



via SPC cable



receiver  
(optional)

deep groove probe (optional), code ISR-C002-DGP1

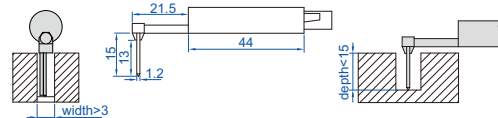

## SPECIFICATION

Parameters	Ra, Rz, Rq, Rv, Rp, RS, R3z, R3y, Rt, Rz (JIS), Rk, Rku, Rsm, Rpc, Rpk, Rvk, Rsk, Mr1, Mr2, Ry (JIS), Rmax	
Range	320μm (-160μm~160μm)	
Accuracy	±10%	
Resolution (Ra)	0.001μm	
Probe	type	inductive
	stylus radius/angle	5μm/90°
	stylus material	diamond
Measuring force	4mN	
Measuring unit	μm/μin	
Cut off	0.25/0.8/2.5mm	
Number of cut-off	1 to 5	
Moving speed	0.5mm/s, 1mm/s	
Memory	100 measurement results	
Output	bluetooth and USB	
Power	built-in rechargeable battery	
Dimension (L×W×H)	141×55×40mm	
Weight	400g	

## STANDARD DELIVERY

Main unit	1 pc
Standard probe	1 pc
Calibration block and support	1 pc of each
Adjustable stand	1 pc
Probe cover	1 pc
Software and USB cable	1 pc
AC/DC adapter	1 pc

## OPTIONAL ACCESSORY

Extension rod	ISR-C002-ER
Transverse rod	ISR-C002-TR
Tiny hole probe	ISR-C002-SBP
Deep groove probe	ISR-C002-DGP
Deep groove probe	ISR-C002-DGP1*
Light duty test stand	ISR-C002-STAND1
Heavy duty test stand	ISR-C002-STAND
Bluetooth printer	ISR-C002-PRINTER
Receiver	ISR-C300-RECEIVER
SPC cable	ISR-C300-SPC

\*Need to be delivered with roughness tester ISR-C002

screen display

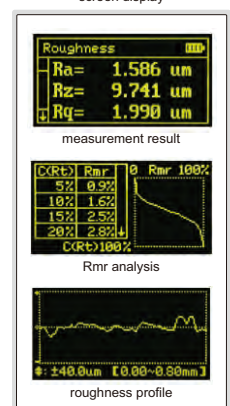

measurement result

Rmr analysis

roughness profile

# ROUGHNESS TESTER (SEPARABLE TYPE) CODE ISR-C300

CAN BE OPERATED BY  
MOBILE PHONES OR COMPUTERS

TOUCH SCREEN

BLUETOOTH

DATA  
OUTPUT

POPULAR  
MODEL



- Roughness tester can be operated by mobile phone (only Android system) or computers
- Data can be sent to Excel by connecting to computers via bluetooth or SPC cable
- Support bluetooth printer
- 22 roughness parameters
- Meet ISO, DIN, ANSI, JIS standards
- Display roughness values, profile and curve
- Memory of maximum 100 data and waveform
- Built-in lithium battery, working time more than 50 hours
- Touch screen
- Automatic power off

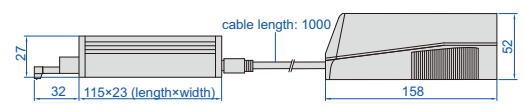
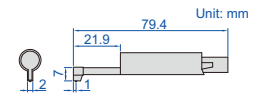

operate roughness tester by computers

connect to computers via USB cable (software is included), display roughness values, profile and curve

operate roughness tester by mobile phones

connect to mobile phones via bluetooth (only Android system), display roughness values, profile and curve

software flash disk (included)

optional probes

<p>extension rod (optional), code ISR-C002-ER</p> <p>probe      extension rod</p>	<p>small hole probe (optional), code ISR-C002-PROBE</p> <p>diameter &gt; Ø5</p>	<p>tiny hole probe (optional), code ISR-C002-SBP</p> <p>diameter &gt; Ø2</p>
<p>2µm/60° probe (optional), code ISR-C300-P2UM (When Ra &lt; 0.5µm, the accuracy with this probe is better)</p>	<p>deep groove probe (optional), code ISR-C002-DGP</p> <p>width &gt; 3      depth &lt; 10</p>	<p>deep groove probe (optional), code ISR-C002-DGP1</p> <p>depth &lt; 5      width &gt; 3</p>

magnetic stand adapter (included)

can be installed on magnetic stands

height gage adapter (optional)

can be installed on height gages

NOTE: Please check whether the adapter can fit your height gages. When using INSIZE height gages, please use the dial test indicator holder of height gages

SPECIFICATION

Parameters		Ra, Rz, Rq, Rv, Rp, Rs, R3z, R3y, Rt, Rc, Rz (JIS), Rk, Rku, Rsm, Rpc, Rpk, Rvk, Rsk, Mr1, Mr2, Ry, Rmax
Range	X axis	17.5mm
	Z axis	320µm (-160µm~160µm)
Accuracy		±10%
Resolution (Ra)		0.001µm
Probe	type	inductive
	stylus radius/angle	5µm/90°
	stylus material	diamond
Measuring force		4mN
Measuring unit		µm/µin
Cut off		0.25/0.8/2.5mm
Number of cut-offs		1~5
Moving speed		0.135mm/s, 0.5mm/s, 1mm/s
Memory		100 measurement results
Output		bluetooth and USB
Power		built-in rechargeable battery
Dimension (L×W×H)		158×64×52mm
Weight		400g

roughness tester screen display

measurement result      roughness profile      Rmr analysis

data can be sent to Excel by connecting to computer via bluetooth or SPC cable

<p>via bluetooth</p> <p>receiver (optional)</p>	<p>via SPC cable</p> <p>SPC cable (optional)</p>
---	--

To be continued

Continued from previous page

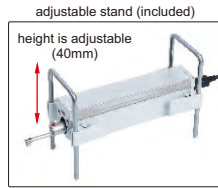
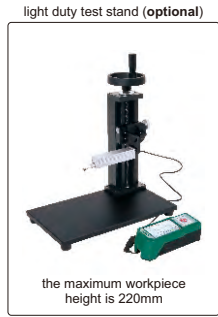

**STANDARD DELIVERY**

Main unit	1 pc
Standard probe	1 pc
Calibration block and support	1 pc of each
Connecting cable (long and short)	1 pc of each
Magnetic stand adapter	1 pc
Adjustable stand	1 pc
Touch pen	1 pc
Software and USB cable	1 pc
AC/DC adapter	1 pc

**OPTIONAL ACCESSORY**

Extension rod	ISR-C002-ER
Small hole probe	ISR-C002-PROBE
Tiny hole probe	ISR-C002-SBP
Deep groove probe	ISR-C002-DGP
Deep groove probe	ISR-C002-DGP1*
2µm/60° probe	ISR-C300-P2UM
Bluetooth printer	ISR-C002-PRINTER
Height gage adapter	ISR-C300-LB1
Receiver	ISR-C300-RECEIVER
SPC cable	ISR-C300-SPC
Support for flat surface	ISR-C300-COVER1
Support for cylindrical surface	ISR-C300-COVER2
Light duty test stand	ISR-C002-STAND1
Heavy duty test stand	ISR-C002-STAND

\*Need to be delivered with roughness tester **ISR-C300**

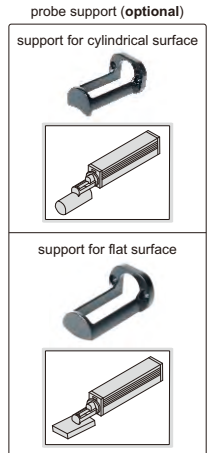

**ROUGHNESS TESTER  
CODE ISR-T120**

DATA OUTPUT

BLUETOOTH

TOUCH SCREEN

CAN BE OPERATED BY  
MOBILE PHONES OR COMPUTERS

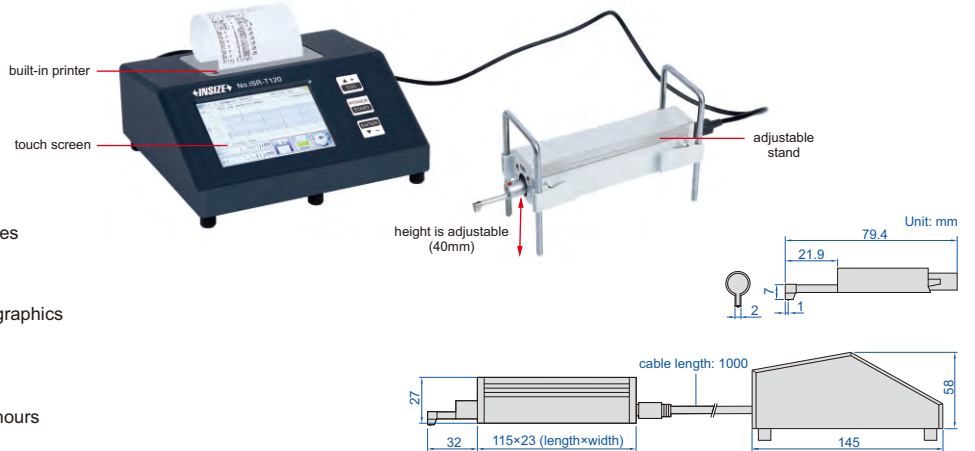

- Roughness tester can be operated by mobile phones (only Android system) or computers
- Data can be sent to Excel by connecting to computers via bluetooth or SPC cable
- Built-in printer can print measurement results and graphics
- 22 roughness parameters
- Meet ISO, DIN, ANSI, JIS standards
- Display roughness values, profile and curve
- Memory of maximum 100 data and waveform
- Built-in lithium battery, working time more than 50 hours
- Automatic power off

operate roughness tester by mobile phones



operate roughness tester by computers

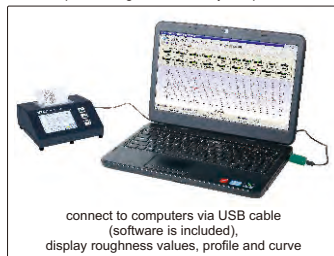

data can be sent to Excel by connecting to computer via bluetooth or SPC cable

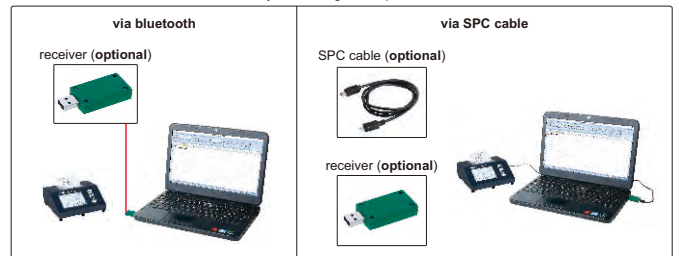

To be continued

Continued from previous page

probe support (optional)

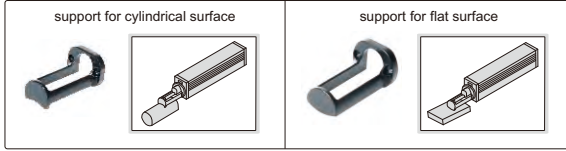

light duty test stand (optional)



heavy duty test stand (optional)



roughness tester screen display

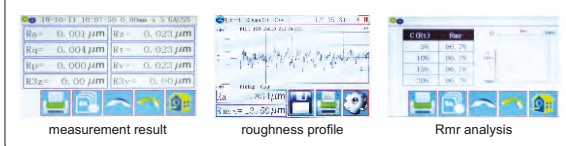

magnetic stand adapter (included)



height gage adapter (optional)



NOTE: Please check whether the adapter can fit your height gages. When using INSIZE height gages, please use the dial test indicator holder of height gages

optional probes

Unit: mm

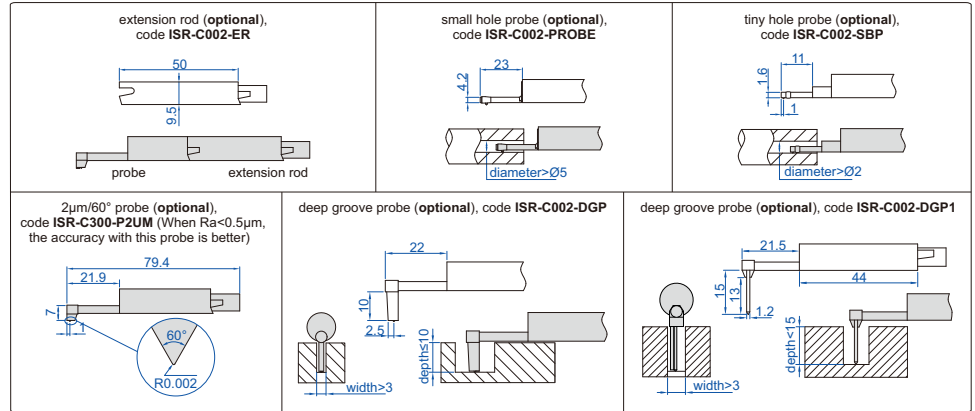

SPECIFICATION

Parameters		Ra, Rz, Rq, Rv, Rp, Rs, R3z, R3y, Rt, Rc, Rz (JIS), Rk, Rku, Rsm, Rpc, Rpk, Rvk, Rsk, Mr1, Mr2, Ry, Rmax
Range	X axis	17.5mm
	Z axis	640µm (-320µm~320µm)
Accuracy		±10%
Resolution (Ra)		0.001µm
Probe	type	inductive
	stylus radius/angle	5µm/90°
	stylus material	diamond
Measuring force		4mN
Measuring unit		µm/µin
Cut off		0.25/0.8/2.5mm
Number of cut-offs		1~5
Traverse speed		0.135mm/s, 0.5mm/s, 1mm/s
Memory		100 measurement results
Output		bluetooth and USB
Power		built-in rechargeable battery
Dimension (L×W×H)		155×145×58mm
Weight		1000g

STANDARD DELIVERY

Main unit	1 pc
Standard probe	1 pc
Calibration block and support	1 pc of each
Magnetic stand adapter	1 pc
Adjustable stand	1 pc
Touch pen	1 pc
Software and USB cable	1 pc
AC/DC adapter	1 pc

OPTIONAL ACCESSORY

Extension rod	ISR-C002-ER
Small hole probe	ISR-C002-PROBE
Tiny hole probe	ISR-C002-SBP
2µm/60° probe	ISR-C300-P2UM
Deep groove probe	ISR-C002-DGP
Deep groove probe	ISR-C002-DGP1 *
Height gage adapter	ISR-C300-LB1
Receiver	ISR-C300-RECEIVER
SPC cable	ISR-C300-SPC
Support for flat surface	ISR-C300-COVER1
Support for cylindrical surface	ISR-C300-COVER2
Light duty test stand	ISR-C002-STAND1
Heavy duty test stand	ISR-C002-STAND

\*Need to be delivered with roughness tester ISR-T120

## ROUGHNESS TESTER (BASIC TYPE) CODE ISR-C003

ATTENTION: THIS ROUGHNESS TESTER IS NOT SUITABLE FOR ROUGH TURNING, MILLING AND PLANING WORKPIECES



- Unit:  $\mu\text{m}$ ,  $\mu\text{in}$
- Automatic power off



### SPECIFICATION

Parameters	Ra, Rz, Rq, Rt	
Range	Ra, Rq: 0.05~15 $\mu\text{m}$ Rz, Rt: 0.1~50 $\mu\text{m}$	
Accuracy	$\pm 10\%$	
Resolution (Ra)	0.01 $\mu\text{m}$	
Probe	type	piezoelectric
	stylus radius/angle	10 $\mu\text{m}/90^\circ$
	stylus material	diamond
Measuring force	5mN	
Measuring unit	$\mu\text{m}/\mu\text{in}$	
Cut off	0.25/0.8/2.5mm	
Evaluation length	1.25mm for cut off 0.25mm 4mm for cut off 0.8mm 5mm for cut off 2.5mm	
Moving speed	0.75mm/s	
Power	built-in rechargeable battery	
Dimension (L×W×H)	106×70×24mm	
Weight	200g	

fixture for small shafts (optional)

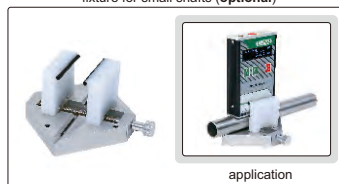

calibration block (included)



### STANDARD DELIVERY

Main unit	1 pc
Calibration block	1 pc
AC/DC adapter	1 pc

### OPTIONAL ACCESSORY

Fixture for small shafts	ISR-C003-FIXTURE
--------------------------	------------------

## SURFACE ROUGHNESS SPECIMEN SET CODE ISR-CS130-W

**INSIZE PLUS**  
MADE IN EUROPE



- For checking, identifying and specifying the roughness by symbol
- Rust-proof, made of pure Nickel

Machining method	Roughness (Ra) *	Roughness (Rz) *	Quantity
Flat lapping	0.05, 0.1, 0.2 $\mu\text{m}$	0.55, 1, 1.6 $\mu\text{m}$	3 pcs
	2, 4, 8 $\mu\text{in}$		
Reaming	0.4, 0.8, 1.6 $\mu\text{m}$	3, 6, 10 $\mu\text{m}$	3 pcs
	16, 32, 63 $\mu\text{in}$		
Plain grinding	0.05, 0.1, 0.2, 0.4, 0.8, 1.6 $\mu\text{m}$	0.55, 1, 1.6, 3, 6, 10 $\mu\text{m}$	6 pcs
	2, 4, 8, 16, 32, 63 $\mu\text{in}$		
Horizontal milling	0.4, 0.8, 1.6, 3.2, 6.3, 12.5 $\mu\text{m}$	2.5, 4, 8, 16, 32, 50 $\mu\text{m}$	6 pcs
	16, 32, 63, 125, 250, 500 $\mu\text{in}$		
Vertical milling	0.4, 0.8, 1.6, 3.2, 6.3, 12.5 $\mu\text{m}$	2.5, 4, 8, 16, 32, 50 $\mu\text{m}$	6 pcs
	16, 32, 63, 125, 250, 500 $\mu\text{in}$		
Turning	0.4, 0.8, 1.6, 3.2, 6.3, 12.5 $\mu\text{m}$	2.5, 4, 8, 16, 32, 50 $\mu\text{m}$	6 pcs
	16, 32, 63, 125, 250, 500 $\mu\text{in}$		

\* The actual value is the value to be calibrated

# MOTORIZED DIGITAL ROCKWELL HARDNESS TESTER CODE HDT-RT151

TOUCH  
SCREEN

BUILT-IN  
BLUETOOTH

FORCE LOADING BY ELECTRIC  
MOTOR (WITHOUT WEIGHTS)



INSPECTION  
CERTIFICATE

POPULAR  
MODEL

- Electronic loading test force, high accuracy of force value, and stable measurement value
- Touch screen operation and display, simple operation interface
- 15 types of Rockwell hardness scales can be tested
- Convertible to various hardness standards such as HB and HV
- 500 sets of storage
- With correction function, the hardness value can be corrected based on the size of the cylinders
- According to ISO 6508

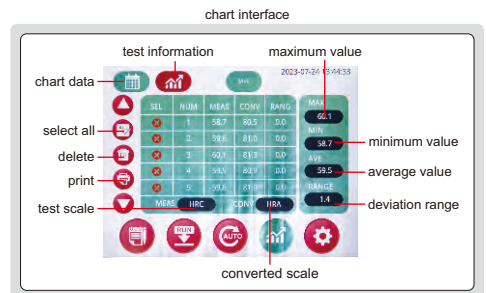
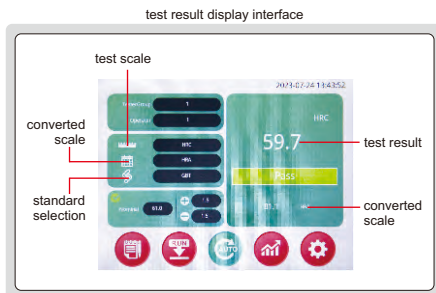
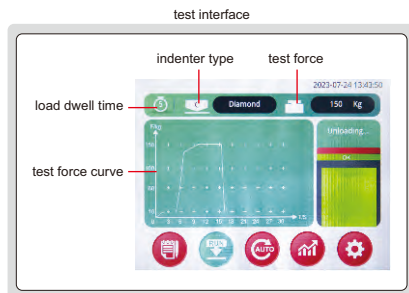
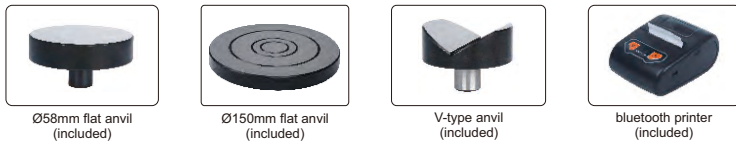
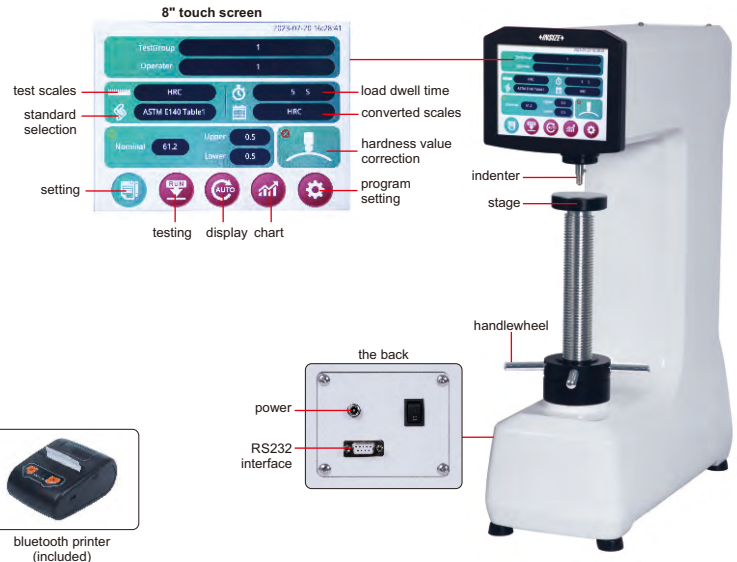

## SPECIFICATION

<b>Measurement range</b>		20~88HRA, 20~100HRB, 20~70HRC
<b>Hardness scale</b>	with indenter included	HRA, HRB, HRC, HRD, HRF, HRG
	with optional indenter	HRE, HRH, HRK, HRL, HRM, HRP, HRR, HRS, HRV
<b>Preliminary test force</b>		98N/10kgf
<b>Test force</b>		588N (60kg), 980N (100kg), 1471N (150kg)
<b>Stage elevation</b>		manual
<b>Load control</b>		automatic (load/dwell/unload)
<b>Load dwell time</b>		2~60 second
<b>Resolution</b>		0.1HR
<b>Max. workpiece height</b>		230mm
<b>Max. testing width</b>		170mm
<b>Power supply</b>		100~240V, 50/60Hz
<b>Dimension</b>		475×200×700mm
<b>Weight</b>		70kg

## STANDARD DELIVERY

<b>Main unit</b>	1 pc
<b>Diamond indenter</b>	1 pc
<b>Ø1.5875mm carbide ball indenter</b>	1 pc
<b>Ø58mm flat anvil</b>	1 pc
<b>Ø150mm flat anvil</b>	1 pc
<b>V-type anvil</b>	1 pc
<b>Hardness test block HRC20~30</b>	1 pc
<b>Hardness test block HRC40~50</b>	1 pc
<b>Hardness test block HRC60~70</b>	1 pc
<b>Hardness test block HRB80~100</b>	1 pc
<b>Hardness test block HRA80~90</b>	1 pc
<b>Bluetooth printer</b>	1 pc
<b>Anti-dust cover</b>	1 pc

## OPTIONAL ACCESSORY

<b>Hardness test block HRC20~30</b>	HDT-B-HRC1
<b>Hardness test block HRC60~70</b>	HDT-B-HRC3
<b>Hardness test block HRB80~100</b>	HDT-B-HRB
<b>Hardness test block HR15N78~88</b>	HDT-B-HR15N2
<b>Hardness test block HR30N55~73</b>	HDT-B-HR30N2
<b>Hardness test block HR30T73~82</b>	HDT-B-HR30T

## MOTORIZED DIGITAL ROCKWELL HARDNESS TESTER CODE ISH-MRD200



software flash disk (included)



VIDEO

- Tolerance testing
- Set testing times (2~10) to have average value and the difference of max. and min. value
- Convert to other Rockwell scales, HV or HB
- Memory of 500 testing values for browsing and output
- Testing value can be sent to wireless printer automatically
- Calibration function compensates the testing value for high accuracy
- The hardness value of soft materials like plastic is not stable, the lock function can obtain the value automatically
- Display unit is automatic power off
- According to ISO 6508
- Keyboard signal, can be transmitted to Excel

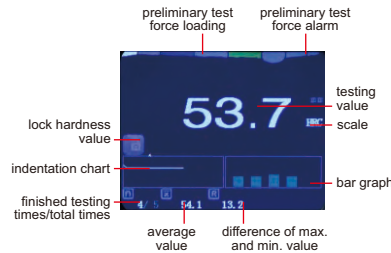

### SPECIFICATION

Hardness scale	HRA, HRB, HRC, HRD, HRF, HRG (with standard indenters)
Hardness scale	HRE, HRH, HRK (with optional indenter)
Preliminary test force	98N
Test force	588N, 980N, 1471N
Stage elevation	manual
Load control	automatic (load/dwell/unload)
Load dwell time	1~99 second
Resolution	0.1HR
Output	wireless and USB
Memory	500
Max. workpiece height	170mm
Max. testing width	165mm (from the center of indenter to the wall of main body)
Power supply of the display unit	built-in rechargeable battery
Power supply	220V, 50/60Hz
Dimension	520×160×700mm
Weight	60kg

### STANDARD DELIVERY

Main unit	1 pc
Ø60mm flat anvil	1 pc
Ø150mm flat anvil	1 pc
V-type anvil	1 pc
Diamond indenter	1 pc
Ø1.5875mm carbide ball indenter	1 pc
Hardness test block HRB88~95	1 pc
Hardness test block HRC60~65	1 pc
Hardness test block HRC20~30	1 pc
Anti-dust cover	1 pc
Software and USB cable	1 pc
AC/DC adapter	1 pc

### OPTIONAL ACCESSORY

Wireless printer	ISH-DS-PRINTER
Ø3.175mm carbide ball indenter	ISH-EHK-INDENTER
Hardness test block HRB88~100	HDT-B-HRB
Hardness test block HRC60~70	HDT-B-HRC3
Hardness test block HRC20~30	HDT-B-HRC1
Small V-type anvil	ISH-SMALLANVIL
Desk	HDT-DESK

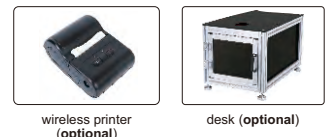
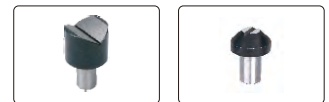
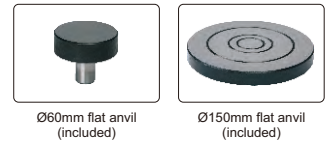

## MANUAL ROCKWELL HARDNESS TESTER CODE ISH-R150

- According to ISO 6508

### SPECIFICATION

Hardness scale	HRA, HRB, HRC, HRD, HRF, HRG
Preliminary test force	98N
Test force	588N, 980N, 1471N
Display	analogue
Stage elevation	manual
Load control	manual
Min. reading	0.5HR
Max. workpiece height	170mm
Max. testing width	165mm (from the center of indenter to the wall of main body)
Dimension	520×160×700mm
Weight	60kg

### STANDARD DELIVERY

Main unit	1 pc
Ø60mm flat anvil	1 pc
Ø150mm flat anvil	1 pc
V-type anvil	1 pc
Diamond indenter	1 pc
Ø1.5875mm carbide ball indenter	1 pc
Hardness test block HRB88~95	1 pc
Hardness test block HRC60~65	1 pc
Hardness test block HRC20~30	1 pc
Anti-dust cover	1 pc

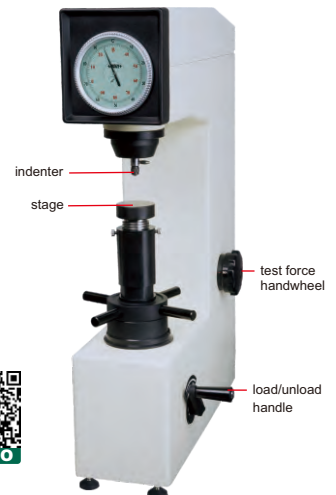

### OPTIONAL ACCESSORY

Hardness test block HRB88~100	HDT-B-HRB
Hardness test block HRC60~70	HDT-B-HRC3
Hardness test block HRC20~30	HDT-B-HRC1
Small V-type anvil	ISH-SMALLANVIL
Desk	HDT-DESK





## MOTORIZED ROCKWELL HARDNESS TESTER (BASIC TYPE) CODE HDT-RA151



### SPECIFICATION

Hardness scale	HRA, HRB, HRC, HRD, HRF, HRG
Preliminary test force	98N
Test force	588N, 980N, 1471N
Display	analogue
Stage elevation	manual
Load control	automatic (load/dwell/unload)
Load dwell time	1~60 second
Min. reading	0.5HR
Max. workpiece height	170mm
Max. testing width	128mm (from the center of indenter to the wall of main body)
Power supply	220V, 50/60Hz
Dimension	500×225×640mm
Weight	65kg

### STANDARD DELIVERY

Main unit	1 pc
Ø58mm flat anvil	1 pc
Ø150mm flat anvil	1 pc
V-type anvil	1 pc
Diamond indenter	1 pc
Ø1.5875mm steel ball indenter	1 pc
Level	1 pc
Hardness test block HRA80~88	1 pc
Hardness test block HRB85~95	1 pc
Hardness test block HRC20~30	1 pc
Hardness test block HRC35~55	1 pc
Hardness test block HRC60~70	1 pc
Anti-dust cover	1 pc



■ According to ISO 6508

### OPTIONAL ACCESSORY

Hardness test block HRA80~84	HDT-B-HRA
Hardness test block HRB88~100	HDT-B-HRB
Hardness test block HRC20~30	HDT-B-HRC1
Hardness test block HRC35~55	HDT-B-HRC2
Hardness test block HRC60~70	HDT-B-HRC3
Small V-type anvil	HDT-RW160-SV
Desk	HDT-DESK



level (included)



Ø150mm flat anvil (included)



Ø58mm flat anvil (included)



V-type anvil (included) for cylinders with diameter Ø4~60mm



small V-type anvil (optional) for cylinders with diameter Ø2~4mm



desk (optional)

## MANUAL ROCKWELL HARDNESS TESTER (BASIC TYPE) CODE HDT-RW160



POPULAR MODEL

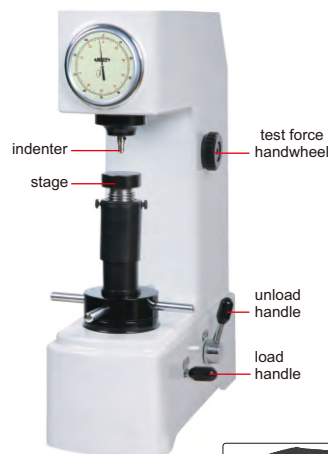

desk (optional)

■ According to ISO 6508

### OPTIONAL ACCESSORY

Hardness test block HRA80~84	HDT-B-HRA
Hardness test block HRB88~100	HDT-B-HRB
Hardness test block HRC20~30	HDT-B-HRC1
Hardness test block HRC35~55	HDT-B-HRC2
Hardness test block HRC60~70	HDT-B-HRC3
Small V-type anvil	HDT-RW160-SV
Desk	HDT-DESK



level (included)



Ø58mm flat anvil (included)



small V-type anvil (optional) for cylinders with diameter Ø2~4mm



Ø150mm flat anvil (included)



V-type anvil (included) for cylinders with diameter Ø4~60mm

### SPECIFICATION

Hardness scale	HRA, HRB, HRC, HRD, HRF, HRG
Preliminary test force	98N (10kg)
Test force	588N (60kg), 980N (100kg), 1471N (150kg)
Display	analogue
Stage elevation	manual
Load control	manual
Min. reading	0.5HR
Max. workpiece height	170mm
Max. testing width	135mm (from the center of indenter to the wall of main body)
Dimension	466×238×630mm
Weight	70kg

### STANDARD DELIVERY

Main unit	1 pc
Ø58mm flat anvil	1 pc
Ø150mm flat anvil	1 pc
V-type anvil	1 pc
Diamond indenter	1 pc
Ø1.5875mm steel ball indenter	1 pc
Ø1.5875mm steel ball	5 pcs
Level	1 pc
Hardness test block HRA80~88	1 pc
Hardness test block HRB85~95	1 pc
Hardness test block HRC20~30	1 pc
Hardness test block HRC35~55	1 pc
Hardness test block HRC60~70	1 pc
Anti-dust cover	1 pc

# DIGITAL MICRO-VICKERS HARDNESS TESTER (BASIC TYPE) CODE HDT-MVE1300



MOTOR DRIVEN  
TURRET

TOUCH  
SCREEN

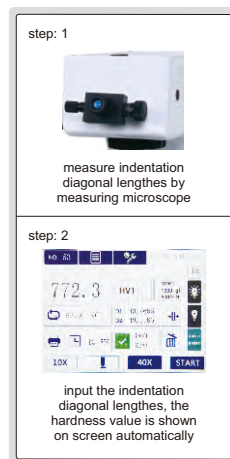
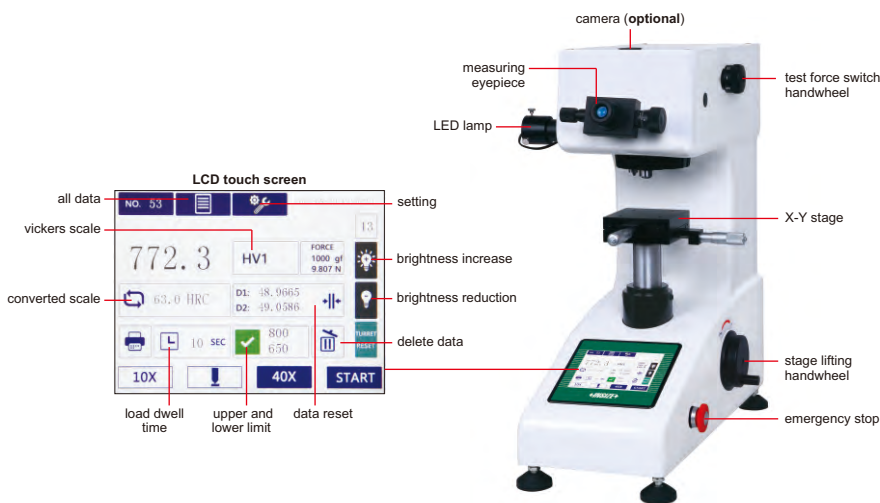

camera (optional)



cylinder holder (included)



slice holder (included)

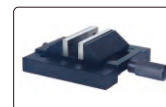

vice (included)



desk (optional)

camera and measuring system (optional)



- Touch screen color LCD display
- Data storage and average value calculation
- Automatic switch between the indenter and objective lens
- According to ISO 6507

## SPECIFICATION

Test force	0.098N (10gf), 0.245N (25gf), 0.49N (50gf), 0.98N (100gf), 1.96N (200gf), 2.94N (300gf), 4.9N (500gf), 9.8N (1kgf)
Vickers scales	HV0.01, HV0.025, HV0.05, HV0.1, HV0.2, HV0.3, HV0.5, HV1
Converted scales	HRA, HRB, HRC, HRD, HRF, HV, HK, HBW, HR15N, HR30N, HR45N, HR15T, HR30T, HR45T
Range	5~3000HV
Length measurement resolution	0.5µm
Objective/indenter switch	motor driven turret
Stage lifting	manual
Load control	automatic (load/dwell/unload)
Load dwell time	1~60 second
Objective	10X, 40X
Eyepiece	10X
Total magnification	100X (for measurement or observation), 400X (for measurement)
Max. workpiece height	90mm
Max. testing width	95mm (from the center of indenter to the wall of main body)
X-Y stage	dimension: 100×100mm, travel range: 25×25mm
Power supply	220V, 50/60Hz
Dimension	510×290×570mm
Weight	40kg

## STANDARD DELIVERY

Main unit	1 pc
10X, 40X objective	1 pc of each
Micro vickers indenter	1 pc
Hardness test block 400~500HV0.2	1 pc
Hardness test block 700~750HV1	1 pc
Slice holder	1 pc
Vice	1 pc
Cylinder holder	1 pc
Anti-dust cover	1 pc

## OPTIONAL ACCESSORY

Hardness test block 400~500HV0.2	HDT-B-HV02C
Hardness test block 700~750HV1	HDT-B-HV1F
Camera	HDT-MVH-CM
Measuring system (manual)	HDT-MVH-SW
Measuring system (automatic)	HDT-MVH-AW
Desk	HDT-DESK

# DIGITAL MICRO-VICKERS HARDNESS TESTER (STANDARD TYPE) CODE HDT-MVH1100

INSPECTION  
CERTIFICATE

PRESS INPUT BUTTON TO HAVE  
DIRECT READING OF HARDNESS

MOTOR DRIVEN  
TURRET

TOUCH  
SCREEN

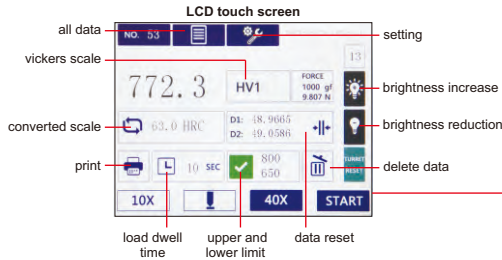
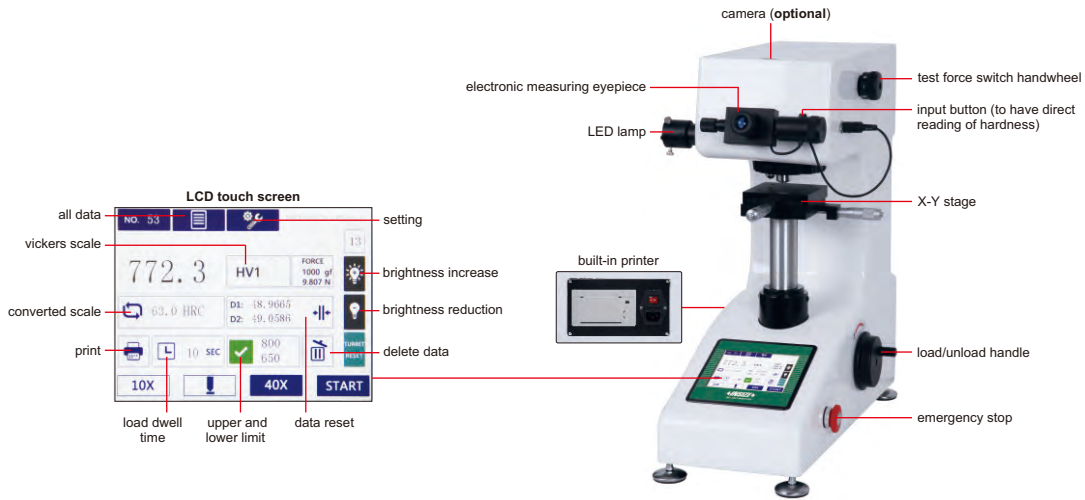

- Touch screen color LCD display
- Data storage and average value calculation
- Automatic switch between the indenter and objective lens
- According to ISO 6507

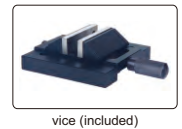

## SPECIFICATION

Test force	0.098N (10gf), 0.245N (25gf), 0.49N (50gf), 0.98N (100gf), 1.96N (200gf), 2.94N (300gf), 4.9N (500gf), 9.8N (1kgf)
Vickers scales	HV0.01, HV0.025, HV0.05, HV0.1, HV0.2, HV0.3, HV0.5, HV1
Converted scales	HRA, HRB, HRC, HRD, HRF, HV, HK, HBW, HR15N, HR30N, HR45N, HR15T, HR30T, HR45T
Range	5~3000HV
Length measurement resolution	0.025µm
Objective/indenter switch	motor driven turret
Stage lifting	manual
Load control	automatic (load/dwell/unload)
Load dwell time	1~60 second
Objective	10X, 40X
Eyepiece	10X
Total magnification	10X (for measurement or observation), 400X (for measurement)
Max. workpiece height	90mm
Max. testing width	95mm (from the center of indenter to the wall of main body)
X-Y stage	dimension: 100×100mm, travel range: 25×25mm
Data output	built-in printer
Power supply	220V, 50/60Hz
Dimension	510×290×570mm
Weight	40kg

## STANDARD DELIVERY

Main unit	1 pc
10X, 40X objective	1 pc of each
Micro Vickers indenter	1 pc
Hardness test block 400~500HV0.2	1 pc
Hardness test block 700~750HV1	1 pc
Slice holder	1 pc
Vice	1 pc
Cylinder holder	1 pc
Anti-dust cover	1 pc

## OPTIONAL ACCESSORY

Hardness test block 400~500HV0.2	HDT-B-HV02C
Hardness test block 700~750HV1	HDT-B-HV1F
Camera	HDT-MVH-CM
Measuring system (manual)	HDT-MVH-SW
Measuring system (automatic)	HDT-MVH-AW

# DIGITAL VICKERS HARDNESS TESTERS (BASIC TYPE)



MOTOR DRIVEN TURRET

TOUCH SCREEN

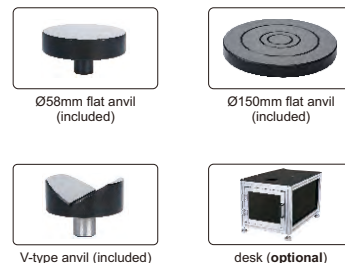
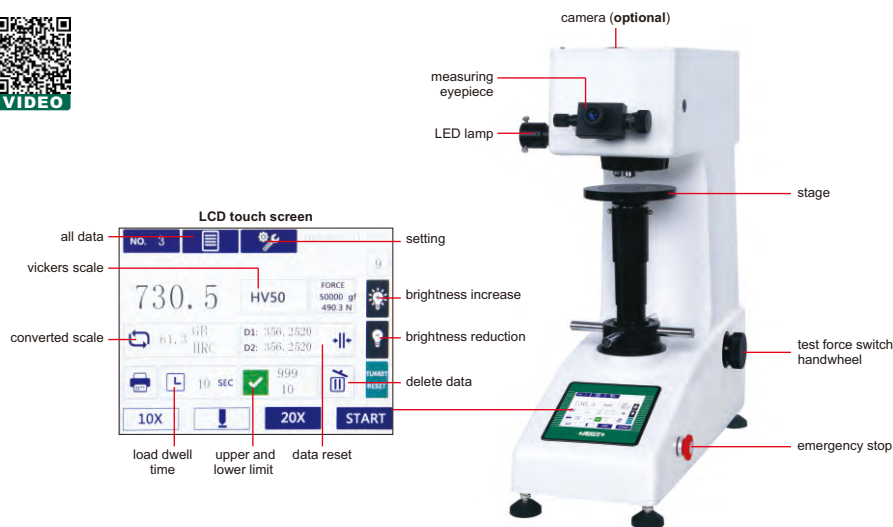

HDT-VE56

camera and measuring system (optional)



Vickers hardness measurement system (optional)

camera (optional)

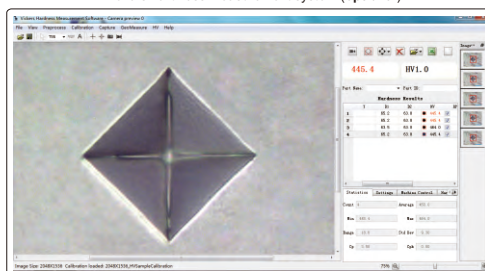

- Touch screen color LCD display
- Data storage and average value calculation
- Automatic switch between the indenter and objective lens
- According to ISO 6507

## SPECIFICATION

Code	HDT-VE03	HDT-VE14	HDT-VE35	HDT-VE56
Test force	0.3kgf, 0.5kgf, 1kgf, 2kgf, 3kgf, 5kgf	0.3kgf, 0.5kgf, 1kgf, 3kgf, 5kgf, 10kgf	1kgf, 3kgf, 5kgf, 10kgf, 20kgf, 30kgf	1kgf, 5kgf, 10kgf, 20kgf, 30kgf, 50kgf
Vickers scales	HV0.3, HV0.5, HV1, HV2, HV3, HV5	HV0.3, HV0.5, HV1, HV3, HV5, HV10	HV1, HV3, HV5, HV10, HV20, HV30	HV1, HV5, HV10, HV20, HV30, HV50
Converted scales	HRA, HRB, HRC, HRD, HRF, HV, HK, HBW, HR15N, HR30N, HR45N, HR15T, HR30T, HR45T			
Range	8~3000HV			
Length measurement resolution	0.5µm			
Objective/indenter switch	motor driven turret			
Stage lifting	manual			
Load control	automatic (load/dwell/unload)			
Load dwell time	1~60 second			
Objective	10X, 20X			
Eyepiece	10X			
Total magnification	100X (for measurement or observation), 200X (for measurement)			
Max. workpiece height	175mm			
Max. testing width	135mm (form the center of indenter to the wall of main body)			
Power supply	220V, 50/60HZ			
Dimension	580×320×660mm			
Weight	55kg			

step: 1



measure indentation diagonal lengths by measuring microscope

step: 2



input the indentation diagonal lengths, the hardness value is shown on screen automatically

## STANDARD DELIVERY

Main unit	1 pc
10X, 20X objective	1 pc of each
Vickers indenter	1 pc
Hardness test block 400~500HV10	1 pc
Hardness test block 700~750HV50	1 pc
Ø58mm flat anvil	1 pc
Ø150mm flat anvil	1 pc
V-type anvil	1 pc
Anti-dust cover	1 pc

## OPTIONAL ACCESSORY

Hardness test block 400~500HV10	HDT-B-HV10D
Hardness test block 700~750HV50	HDT-B-HV50G
Desk	HDT-DESK
Vickers hardness tester camera	HDT-MVH-CM1
Measuring system (manual)	HDT-MVH-SW
Measuring system (automatic)	HDT-MVH-AW

## DIGITAL VICKERS HARDNESS TESTERS (STANDARD TYPE)

MOTOR DRIVEN  
TURRET

PRESS INPUT BUTTON TO HAVE  
DIRECT READING OF HARDNESS

TOUCH  
SCREEN

INSPECTION  
CERTIFICATE



- Touch screen color LCD display
- Data storage and average value calculation
- Automatic switch between the indenter and objective lens
- According to ISO 6507

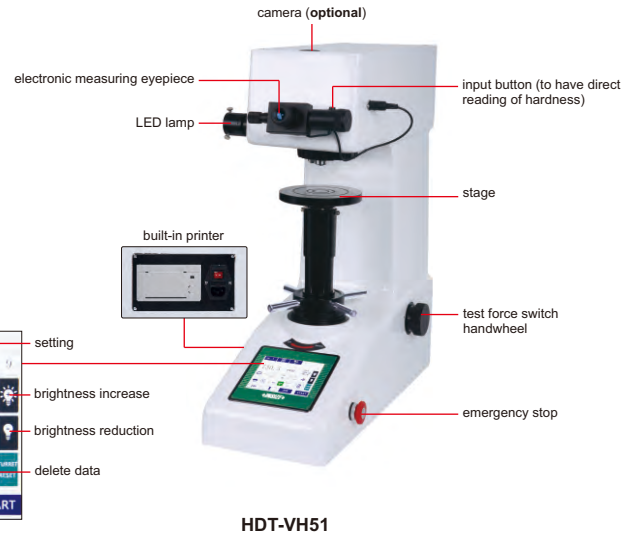

HDT-VH51

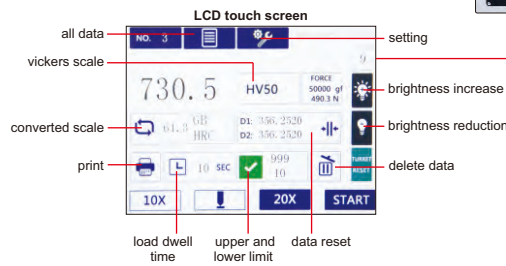

### SPECIFICATION

Code	HDT-VH05	HDT-VH11	HDT-VH31	HDT-VH51
Test force	0.3kgf, 0.5kgf, 1kgf, 2kgf, 3kgf, 5kgf	0.3kgf, 0.5kgf, 1kgf, 3kgf, 5kgf, 10kgf	1kgf, 3kgf, 5kgf, 10kgf, 20kgf, 30kgf	1kgf, 5kgf, 10kgf, 20kgf, 30kgf, 50kgf
Vickers scales	HV0.3, HV0.5, HV1, HV2, HV3, HV5	HV0.3, HV0.5, HV1, HV3, HV5, HV10	HV1, HV3, HV5, HV10, HV20, HV30	HV1, HV5, HV10, HV20, HV30, HV50
Converted scales	HRA, HRB, HRC, HRD, HRF, HV, HK, HBW, HR15N, HR30N, HR45N, HR15T, HR30T, HR45T			
Range	8~3000HV			
Length measurement resolution	0.125µm			
Objective/indenter switch	motor driven turret			
Stage lifting	manual			
Load control	automatic (load/dwell/unload)			
Load dwell time	1~60 second			
Objective	10X, 20X			
Eyepiece	10X			
Total magnification	100X (for measurement or observation), 200X (for measurement)			
Max. workpiece height	175mm			
Max. testing width	135mm (form the center of indenter to the wall of main body)			
Output	built-in printer			
Power supply	220V, 50/60HZ			
Dimension	580×320×660mm			
Weight	55kg			



Ø58mm flat anvil (included)



V-type anvil (included)



Ø150mm flat anvil (included)



desk (optional)



camera (optional)

### STANDARD DELIVERY

Main unit	1 pc
10X, 20X objective	1 pc of each
Vickers indenter	1 pc
Hardness test block	2 pcs
Ø58mm flat anvil	1 pc
Ø150mm flat anvil	1 pc
V-type anvil	1 pc
Anti-dust cover	1 pc

### OPTIONAL ACCESSORY

Hardness test block	see details
Desk	HDT-DESK
Vickers hardness tester camera	HDT-MVH-CM1
Measuring system (manual)	HDT-MVH-SW
Measuring system (automatic)	HDT-MVH-AW

vickers hardness measurement system (optional)

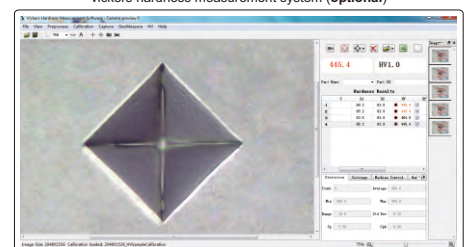

**MOTORIZED DIGITAL BRINELL HARDNESS TESTER (BASIC TYPE)  
CODE HDT-MBE320**

FORCE LOADING BY ELECTRIC MOTOR (WITHOUT WEIGHT)

TOUCH SCREEN

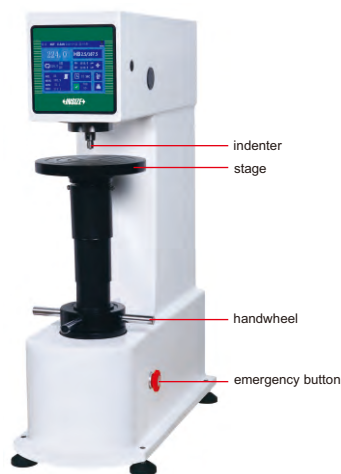
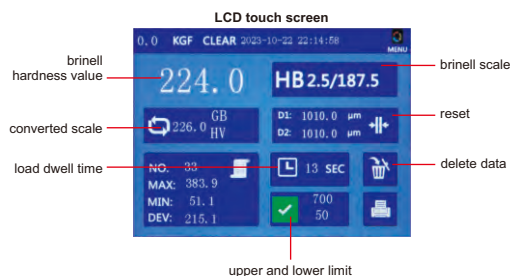

- Touch screen color LCD display SCREEN
- Measure indentation diameter by measuring microscope, then input the diameters, the hardness value is shown on screen automatically
- Electric loading test force, without weights
- Casting case, structurally stable and not deformed
- According to ISO 6506

**SPECIFICATION**

Test force	62.5kgf, 100kgf, 125kgf, 187.5kgf, 250kgf, 500kgf, 750kgf, 1000kgf, 1500kgf, 3000kgf	
Brinell scale	HBW2.5/62.5, HBW2.5/187.5, HBW5/62.5, HBW5/125, HBW5/250, HBW5/750, HBW10/100, HBW10/250, HBW10/500, HBW10/1000, HBW10/1500, HBW10/3000	
Range	8~650HBW	
Hardness resolution	0.1HBW	
Stage elevation	manual	
Load control	automatic (load/dwell/unload)	
Load dwell time	0~60 second	
Measuring microscope	magnification	20X
	resolution	0.01mm
Max. workpiece height	230mm	
Max. testing width	140mm (form the center of indenter to the wall of main body)	
Power supply	220V, 50/60Hz	
Dimension	510×210×750mm	
Weight	130kg	

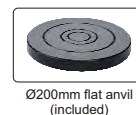

**STANDARD DELIVERY**

Main unit	1 pc
Ø78mm flat anvil	1 pc
Ø200mm flat anvil	1 pc
V-type anvil	1 pc
Ø2.5mm carbide ball indenter	1 pc
Ø5mm carbide ball indenter	1 pc
Ø10mm carbide ball indenter	1 pc
Hardness test block 100~200HBW2.5/187.5	1 pc
Hardness test block 90~200HBW10/1000	1 pc
Hardness test block 100~200HBW10/3000	1 pc
Measuring microscope	1 pc

**OPTIONAL ACCESSORY**

Hardness test block 100~200HBW2.5/187.5	HDT-B-HB25A1
Hardness test block 90~200HBW10/1000	HDT-B-HB10C1
Hardness test block 100~200HBW10/3000	HDT-B-HB10A1
Desk	HDT-DESK

## MOTORIZED DIGITAL BRINELL HARDNESS TESTERS (STANDARD TYPE)

INSPECTION CERTIFICATE

TOUCH SCREEN

FORCE LOADING BY ELECTRIC MOTOR (WITHUOT WEIGHT)

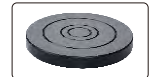
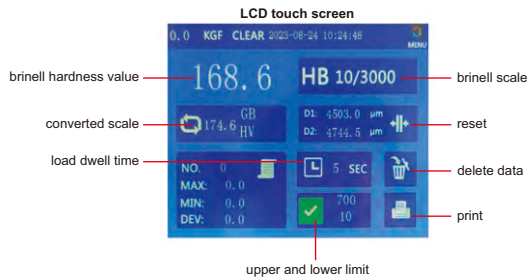

- Touch screen color LCD display
- Measure the indentation with microscope, automatically calculate the hardness value and display it on the screen
- Electric loading test force, without weights
- Casting case, structurally stable and not deformed
- According to ISO 6506

### SPECIFICATION

Code	HDT-MB610	HDT-MB710
Turret rotation	manual	automatic
Test force	62.5kgf, 100kgf, 125kgf, 187.5kgf, 250kgf, 500kgf, 750kgf, 1000kgf, 1500kgf, 3000kgf	
Brinell scale	HBW2.5/62.5, HBW2.5/187.5, HBW5/125, HBW5/750, HBW10/100, HBW10/250, HBW10/500, HBW10/1000, HBW10/1500, HBW10/3000	
Range	8~650HBW	
Hardness resolution	0.1HBW	
Stage elevation	manual	
Load control	automatic (load/dwell/unload)	
Load dwell time	0~60 second	
Measuring microscope	magnification	20X
	resolution	0.1μm
Max. workpiece height	200mm	
Max. testing width	135mm (form the center of indenter to the wall of main body)	
Data output	built-in printer, RS232	
Power supply	220V, 50/60Hz	
Dimension	510×210×750mm	
Weight	130kg	

### STANDARD DELIVERY

Main unit	1 pc
Ø78mm flat anvil	1 pc
Ø200mm flat anvil	1 pc
V-type anvil	1 pc
Ø2.5mm carbide ball indenter	1 pc
Ø5mm carbide ball indenter	1 pc
Ø10mm carbide ball indenter	1 pc
Hardness test block 100~200HBW2.5/187.5	1 pc
Hardness test block 90~200HBW10/1000	1 pc
Hardness test block 100~200HBW10/3000	1 pc

### OPTIONAL ACCESSORY

Hardness test block 100~200HBW2.5/187.5	HDT-B-HB25A1
Hardness test block 90~200HBW10/1000	HDT-B-HB10C1
Hardness test block 100~200HBW10/3000	HDT-B-HB10A1
Desk	HDT-DESK

# BRINELL/ROCKWELL/VICKERS HARDNESS TESTER CODE ISH-BRV



■ According to ISO 6506, ISO 6507, ISO 6508



Ø60mm flat anvil for Rockwell (included)

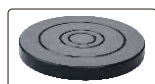

Ø150mm flat anvil for Rockwell (included)



Ø60mm flat anvil for Vickers and Brinell (included)



V-type anvil for Rockwell (included), for cylinders with diameter Ø4-60mm



V-type anvil for Vickers and Brinell (included)



small V-type anvil for Rockwell (optional), for cylinders with diameter Ø2-4mm



desk (optional)

## SPECIFICATION

Rockwell test load	98N preload, 588, 980, 1471N total load
Min. Rockwell reading	0.5HR
Brinell test load	306, 613, 1839N
Vickers test load	294N
Stage elevation	manual
Load control	manual
Magnification of microscope	37.5X/75X
Max. workpiece height	180mm
Max. testing width	200mm (from the center of indenter to the wall of main body)
Power supply	220V, 50/60Hz
Dimension	546×300×767mm
Weight	90kg

## STANDARD DELIVERY

Main unit	1 pc
Ø1.5875mm carbide ball indenter	1 pc
Diamond Rockwell indenter	1 pc
Ø5mm Brinell indenter	1 pc
Ø2.5mm Brinell indenter	1 pc
Vickers indenter	1 pc
Ø60mm flat anvil for Rockwell	1 pc
Ø150mm flat anvil for Rockwell	1 pc
V-type anvil for Rockwell	1 pc
Ø60mm flat anvil for Vickers and Brinell	1 pc
V-type anvil for Vickers and Brinell	1 pc
Hardness test block HRB88-95	1 pc
Hardness test block HRC60-65	1 pc
Hardness test block HRC20-30	1 pc
Hardness test block 400-500HV30	1 pc
Hardness test block 180-300HBW2.5/187.5	1 pc
Anti-dust cover	1 pc

## OPTIONAL ACCESSORY

Hardness test block HRB88-100	HDT-B-HRB
Hardness test block HRC60-70	HDT-B-HRC3
Hardness test block HRC20-30	HDT-B-HRC1
Hardness test block 400-500HV30	HDT-B-HV30D
Hardness test block 200-3000HBW2.5/187.5	HDT-B-HB25A2
Small V-type anvil for Rockwell	ISH-SMALLANVIL
Desk	HDT-DESK



# PORTABLE LEEB HARDNESS TESTERS (BASIC TYPE)

INSPECTION  
CERTIFICATE

POPULAR  
MODEL



- Can change probes
- Dual-coil probe for high accuracy
- Universal testing angle, no need to set impact direction
- Based on Leeb (HLD), converted to Vickers (HV), Brinell (HB), Rockwell (HRC, HRB), Shore (HSD) and tensile strength ( $\sigma_b$ )
- Dual value display, shows both Leeb and converted hardness
- Large LCD display with backlight
- Can choose large font display and statistics display
- Automatically calculate maximum, minimum and average value
- Save 300 data
- Operation temperature: -10°C~45°C
- According to ASTM A956, GB/T 17394



HDT-LP200

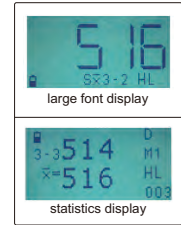

## SPECIFICATION

Code	HDT-LP200	HDT-LP200B
Printer	not included	included
Resolution	1HLD/1HV/1HB/0.1HRC/0.1HRB/0.1HSD/1 $\sigma_b$	
Accuracy	±6HLD (when HLD=800)	
Measuring range	HL 170-960/HRC 17-70/HRB 13-109/ HB 20-655/HV 80-940/HSD 32-99.5/ $\sigma_b$ ( $rm$ ) 255-2639N/mm <sup>2</sup>	
Power supply	2xAA battery	
Dimension	135×77×32mm	
Weight	240g	



hardness test block D (included)



small support ring (included)



bluetooth printer (included in HDT-LP200B)

## STANDARD DELIVERY

Main unit	1 pc
Hardness test block D	1 pc
Small support ring	1 pc
Cleaning brush	1 pc
Impact device D	1 pc
Bluetooth printer (included in HDT-LP200B)	1 pc

## OPTIONAL ACCESSORY

Impact device DC	HDT-LP200-DC
Impact device C	HDT-LP200-C
Impact device D+15	HDT-LP200-D15
Impact device DL	HDT-LP200-DL
Impact device G	HDT-LP200-G
Hardness test block D **	HDT-B-HLD3
Hardness test block G *	HDT-B-HLG2
Support rings	see details

\*Hardness test block G (HDT-B-HLG2) is for impact device G (HDT-LP200-G)

\*\*Hardness test block D (HDT-B-HLD3) is for all other impact devices

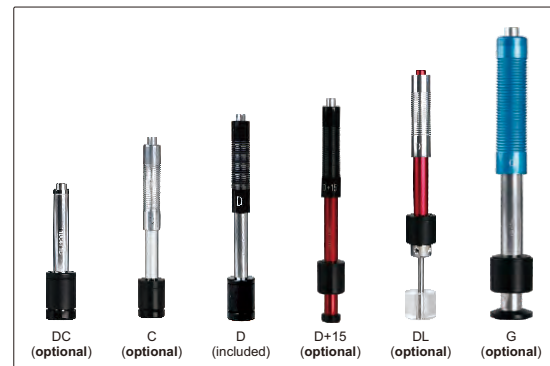

## APPLICABLE WORKPIECE

Impact device	DC	C	D	D+15	DL	G
Application	inner wall of small space	small or thin workpiece, coating layer	general use	deep groove	narrow slot or small hole	casting or forging workpiece
Maximum roughness of workpiece (Ra)	2 $\mu$ m	0.4 $\mu$ m	2 $\mu$ m	2 $\mu$ m	2 $\mu$ m	7 $\mu$ m
Minimum weight of workpiece	direct measurement	5kg	1.5kg	5kg	5kg	15kg
	on solid support	2kg	0.5kg	2kg	2kg	5kg
	coupled on plate	0.05kg	0.02kg	0.05kg	0.1kg	0.05kg
Minimum thickness of workpiece	3mm	1mm	3mm	3mm	3mm	10mm

# PORTABLE LEEB HARDNESS TESTER WITH WIRELESS PROBE CODE HDT-WP201



- Bluetooth digital probe
- Universal testing angle, no need to set impact direction
- Based on Leeb (HLD), converted to Vickers (HV), Brinell (HB), Rockwell (HRC, HRB), Shore (HSD) and tensile strength (σb)
- Dual value display, shows both Leeb and converted hardness
- Large LCD display with backlight
- Can choose large font display and statistics display
- Automatically calculate maximum, minimum and average value
- Save 300 data
- Operation temperature: -10°C~45°C
- According to ASTM A956, DIN 50156 GB/T 17394



### SPECIFICATION

<b>Resolution</b>	1HLD/1HV/1HB/0.1HRC/0.1HRB/ 0.1HSD/1σb
<b>Accuracy</b>	±6HLD (when HLD=800)
<b>Measuring range</b>	HL 170-960/HRC 17-69/HRB 13-101.7/ HB 20-655/HV 80-940/HSD 32-99.5/ σb (rm) 255-2180N/mm <sup>2</sup>
<b>Power supply</b>	2xAA battery
<b>Dimension</b>	135×77×32mm
<b>Weight</b>	240g



hardness test block D (included)



small support ring (included)



bluetooth printer (optional)

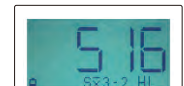

large font display

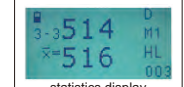

statistics display

### STANDARD DELIVERY

<b>Main unit</b>	1 pc
<b>Hardness test block D</b>	1 pc
<b>Small support ring</b>	1 pc
<b>Cleaning brush</b>	1 pc
<b>Impact device D</b>	1 pc

### OPTIONAL ACCESSORY

<b>Impact device DC</b>	HDT-WL320-DCW
<b>Impact device C</b>	HDT-WL320-CW
<b>Impact device DL</b>	HDT-WL320-DLW
<b>Impact device G</b>	HDT-WL320-GW
<b>Hardness test block D</b>	HDT-B-HLD3
<b>Bluetooth printer</b>	ISH-LP201-PRINTER
<b>Support rings</b>	see details

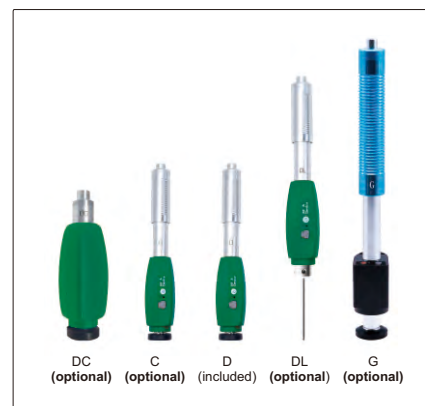

### APPLICABLE WORKPIECE

Impact device	DC	C	D	DL	G
<b>Application</b>	inner wall of small space	small or thin workpiece, coating layer	general use	narrow slot or small hole	casting or forging workpiece
<b>Maximum roughness of workpiece (Ra)</b>	2μm	0.4μm	2μm	2μm	7μm
<b>Minimum weight of workpiece</b>	direct measurement	5kg	1.5kg	5kg	15kg
	on solid support	2kg	0.5kg	2kg	5kg
	coupled on plate	0.05kg	0.02kg	0.05kg	0.05kg
<b>Minimum thickness of workpiece</b>	3mm	1mm	3mm	3mm	10mm

# PEN-TYPE LEEB HARDNESS TESTER (ADVANCED TYPE) CODE HDT-L410

- DATA OUTPUT
- HIGH ACCURACY
- DL PROBE IS OPTIONAL



- Metal housing
- HD TFT 320×320 display
- Impact device D
- Based on Leeb (HLD), converted to Vickers (HV), Brinell (HB), Rockwell (HRC, HRA and HRB), Shore (HS) and tensile strength (SGM)
- Four display modes
- Automatic direction correction
- Tolerance testing
- Automatic power off, automatic calculation of statistics
- Dual value display, shows both Leeb and other conversion values
- 31 files can be saved, each containing 100 measurement data
- Connected to PC software via USB or Bluetooth 2.0
- Connected with printer via Bluetooth
- Operation temperature: -20°C~70°C
- According to ASTM A956, DIN 50156, GB/T 17394



DL probe can be installed (optional)



software flash disk (included)



small support ring (included)



hardness test block D (included)



wireless printer (optional)

histogram display

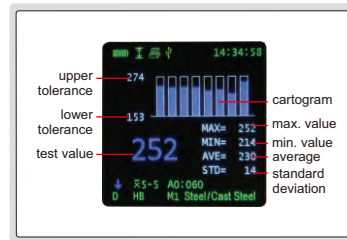

dynamic ring display

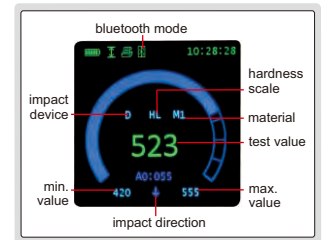

can choose large font display

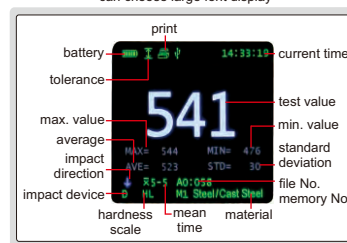

statistic display

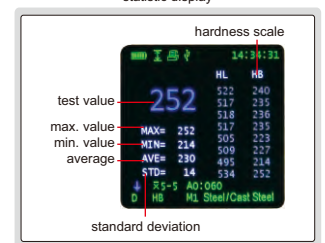

software (included), upload the memory to PC, print and send to EXCEL

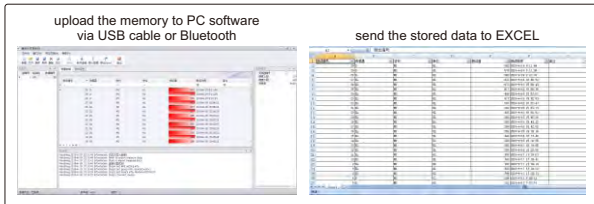

## SPECIFICATION

Resolution	1HLD, 1HV, 1HB, 0.1HRC, 0.1HRB, 0.1HRA, 0.1HS, 1SGM	
Accuracy	±4HLD (when HLD=800)	
Output	USB and bluetooth	
Applicable workpiece	minimum weight	5kg (direct measurement)
		2kg (on solid support)
		0.05kg (coupled on plate)
	minimum thickness: 5mm	
minimum radius of curved surface: 30mm		
maximum roughness (Ra): 2µm		
Power supply	built-in 3.7V rechargeable battery	
Dimension	148×44×22mm	
Weight	115g	

## STANDARD DELIVERY

Main unit	1 pc
Hardness test block D	1 pc
Small support ring	1 pc
Cleaning brush	1 pc
AC/DC adapter	1 pc
Software flash disk and USB cable	1 pc

## OPTIONAL ACCESSORY

Printer	HDT-L410-PRINTER
Support rings	ISH-PH-SP9
Hardness test block D	HDT-B-HLD3
DL probe	HDT-L410-DL

**PEN-TYPE LEEB HARDNESS TESTER (BASIC TYPE)  
CODE HDT-L411**

INSPECTION  
CERTIFICATE

DATA  
OUTPUT



- Impact device D
- Universal testing angle, no need to set impact direction
- Dual-coil probe, high accuracy
- Based on Leeb (HLD), converted to Vickers (HV), Brinell (HB), Rockwell (HRC, HRA and HRB), Shore (HS) and tensile strength (SGM)
- Dual value display, shows both Leeb and converted hardness
- High contrast digital LCD display
- Can choose large font display
- Automatically calculate maximum, minimum, average value
- Connected to PC via USB
- Save 999 data
- Operation temperature: -20°C~45°C
- According to ASTM A956, DIN 50156, GB/T 17394



software flash disk (included)



hardness test block D (included)



small support ring (included)

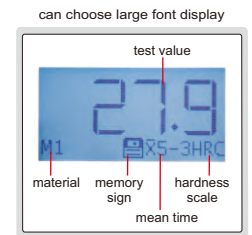

can choose large font display

**SPECIFICATION**

<b>Resolution</b>	1HLD, 1HV, 1HB, 0.1HRC, 0.1HRB, 0.1HRA, 0.1HS, 1SGM	
<b>Accuracy</b>	±6HLD (when HLD=800)	
<b>Output</b>	USB	
<b>Measuring range</b>	HL100-960, HRC1-74.7, HRB1.2-140, HB28-1027, HV45-1230, HS4-112, HRA7-88.5, SGM (rm) 118-3315N/mm <sup>2</sup>	
<b>Applicable workpiece</b>	minimum weight	5kg (direct measurement)
		2kg (on solid support)
		0.05kg (coupled on plate)
	minimum thickness: 5mm	
	minimum radius of curved surface: 30mm	
	maximum roughness (Ra): 2µm	
<b>Power supply</b>	1xAAA battery	
<b>Dimension</b>	148×45×21mm	
<b>Weight</b>	105g	

**STANDARD DELIVERY**

Main unit	1 pc
Hardness test block D	1 pc
Cleaning brush	1 pc
AAA battery	1 pc
Small support ring	1 pc
Software flash disk and USB cable	1 pc

software (included), upload the memory to PC, print and send to EXCEL

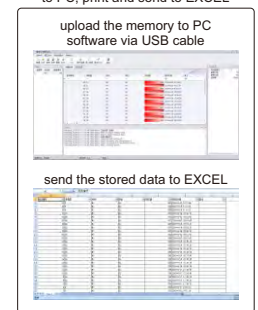

**OPTIONAL ACCESSORY**

Support rings	ISH-PH-SP9
Hardness test block D	HDT-B-HLD3

**PORTABLE ROCKWELL HARDNESS TESTER  
CODE ISHR-P151**



base (included)



anvil extension for thin workpieces (included)



flat anvil (included)



V-type anvil (included)

- According to ISO 6508, ASTM E18

**SPECIFICATION**

<b>Hardness scale</b>	HRA, HRB, HRC, HRD, HRF, HRG
<b>Preliminary test force</b>	10kg
<b>Test force</b>	60kg, 100kg, 150kg
<b>Load control</b>	manual
<b>Min. reading</b>	1HR
<b>Max. workpiece thickness</b>	25mm
<b>Max. testing width</b>	25mm (from the center of indenter to the main body)
<b>Dimension</b>	240×70×160mm
<b>Weight (with base)</b>	2.5kg

**STANDARD DELIVERY**

Main unit	1 pc
Diamond indenter	1 pc
Ø1.5875mm carbide ball indenter	2 pcs
Hardness test block HRB88~95	1 pc
Hardness test block HRC60~65	1 pc
Hardness test block HRC20~30	1 pc
Flat anvil	1 pc
V-type anvil	1 pc
Base	1 pc
Anvil extension	1 pc
Magnifier	2 pcs

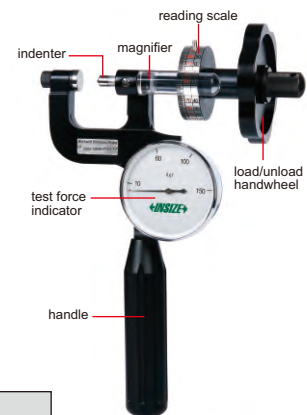

## ALUMINUM HARDNESS TESTERS (BASIC TYPE)

- To measure the hardness of soft metal such as aluminum alloy, copper, brass, soft steel, etc.
- According to ASTM B647-10 (2016)



### STANDARD DELIVERY

Main unit	1 pc
Spare indenter	1 pc
Hardness test block	1 pc
Wrench	1 pc

### SPECIFICATION

Code	ISHW-H10	ISHW-H11	ISHW-H12	ISHW-H13	ISHW-H14	ISHW-H15
Application	for aluminum alloy general use	for aluminum alloy thick workpiece	for aluminum alloy small tube	for hard aluminum alloy and hard brass	for soft brass and copper	for soft steel and cold-rolled steel
Thickness requirement of flat workpiece	0.6~6mm	0.6~13mm	0.6~8mm	0.6~6mm	0.6~6mm	0.6~6mm
Internal diameter requirement of tube workpiece	>Ø10mm	>Ø10mm	>Ø6mm	>Ø10mm	>Ø10mm	>Ø10mm
Wall thickness requirement of tube workpiece	0.6~6mm	6~13mm (internal diameter Ø10~23.3mm) 6~13mm (internal diameter >Ø23.3mm)	0.6~8mm	0.6~6mm	0.6~6mm	0.6~6mm
Hardness range	0~20HW					
Min. reading	1HW					
Accuracy	±0.5HW (at 5~17HW)					
Dimension	205×30×95mm					
Weight	500g					

## ALUMINUM HARDNESS TESTER CODE ISHB-B300

### SPECIFICATION

Hardness range	0~100HBa (equal to 25~150HBW)
Min. reading	1HBa
Accuracy	±2HBa (at 42~52HBa) ±1HBa (at 84~88HBa)
Min. workpiece thickness	0.8mm
Dimension	142×65×90mm
Weight	500g

- To measure the hardness of workpieces made of pure aluminum, aluminum alloy, fiber reinforced plastic, hard plastic, etc.
- According to ASTM B648-00, ASTM D2853-07

### STANDARD DELIVERY

Main unit	1 pc
Spare indenter	2 pcs
Hardness test block	2 pcs
Wrench	1 pc



## DIGITAL SHORE DUROMETERS

- According to ISO868, ISO7619, ASTM D 2240
- Average and peak (max.) mode
- Dwell time is adjustable
- Tolerance testing
- 500 memories
- Wireless connection to printer
- Handhold use or work with test stand (code ISH-DS-STANDA)
- Automatic power off

### SPECIFICATION

Code	ISH-DSA	ISH-DSD
Unit	Shore A	Shore D
Test material	soft plastic, soft rubber, etc.	hard plastic, hard rubber, etc.
Measuring range	0~100HA*	0~100HD*
Resolution	0.1HA	0.1HD
Accuracy	±1HA	±1HD
Indenter protrusion	2.5mm	
Output	wireless and USB	
Power supply	built-in rechargeable battery	
Dimension	153×50×29mm	
Weight	170g	

\* Use ISH-DSD when measuring result is higher than 90HA  
Use ISH-DSA when measuring result is lower than 20HD

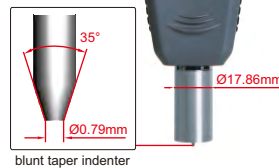

ISH-DSA

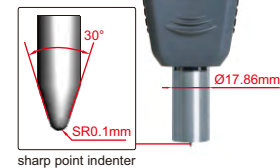

ISH-DSD



calibration block (included)



software flash disk (included)



printer (optional)

### STANDARD DELIVERY

Main unit	1 pc
Calibration block	1 pc
Software and USB cable	1 pc
AC/DC adapter	1 pc

### OPTIONAL ACCESSORY

Printer	ISH-DS-PRINTER
Test stand	ISH-DS-STANDA

## TEST STAND FOR DIGITAL SHORE DUROMETERS CODE ISH-DS-STANDA

- For digital shore durometers (code **ISH-DSA** and **ISH-DSD**)
- Can perform repeatable hardness measurement due to fewer possibilities of human error or measurement variations
- Special structure for stable loading
- Weight block A is for **ISH-DSA**, weight block D is for **ISH-DSD**

### SPECIFICATION

Stage diameter	Ø115mm
Max. workpiece height	45mm
Max. testing width	63mm (from test point to the column)
Dimension	Ø195×370mm
Weight	5.61kg

### STANDARD DELIVERY

Test stand	1 pc
Weight block A (for ISH-DSA)	1 pc



weight block D (optional)  
for ISH-DSD



### OPTIONAL ACCESSORY

Weight block D (for ISH-DSD) ISH-DS-W4

## SHORE DUROMETERS

- According to ISO868, ISO7619, ASTM D 2240
- With peak value indicator
- Optional accessory:  
test stand **ISH-STAC** and **ISH-STD**

### SPECIFICATION

Code	ISH-SAM	ISH-SDM
Scale	Shore A	Shore D
Application	natural rubber, soft elastomer, etc.	hard elastomer, plastic, hard rubber, etc.
Measuring range*	10~90HA	20~90HD
Graduation	1HA	1HD
Indenter protrusion	2.5mm	
Dimension	115x60x25mm	
Net weight	160g	

\*Use **ISH-SDM** when measuring result is higher than 90HA  
Use **ISH-SAM** when measuring result is lower than 20HD

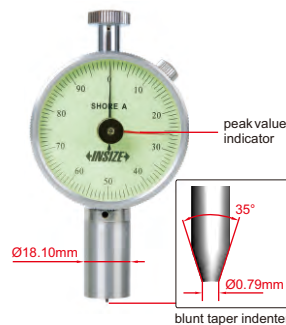

ISH-SAM

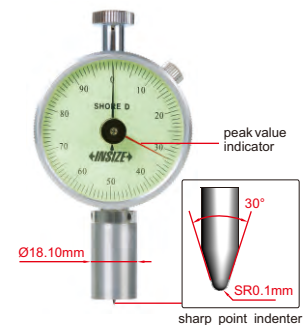

ISH-SDM



### OPTIONAL ACCESSORY

Calibration block ISH-DS-BLOCK

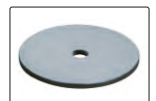

calibration block  
(optional)

## TEST STAND FOR SHORE DUROMETER

- For shore durometers (code **ISH-SAM** and **ISH-SDM**)
- Perform repeatable hardness measurement due to fewer possibilities of human error or measurement variations

### SPECIFICATION

Code	ISH-STAC
Applicable durometer	ISH-SAM
Stage diameter	Ø100mm
Max. workpiece height	75mm
Max. testing width	65mm (from test point to the column)
Weight block	1kg



ISH-STAC



## ELECTRONIC UNIVERSAL TESTING MACHINES

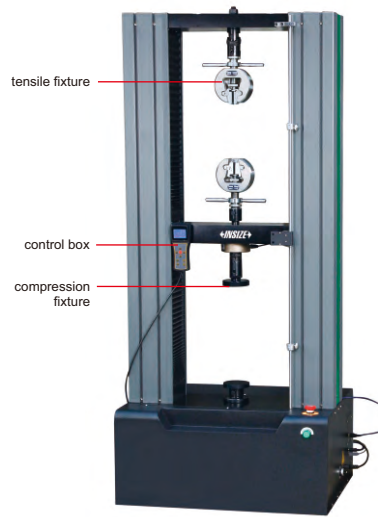
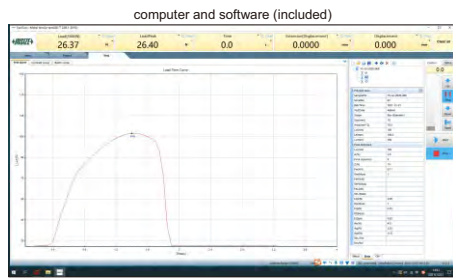

UTM-E50

- For tensile, compression, bend, shear, peel, tear tests of metal and non-metal materials

### SPECIFICATION

Code	UTM-E10	UTM-E50	UTM-E100	UTM-E300
Max. test force	10kN	50kN	100kN	300kN
Accuracy class	0.5 class			
Test force measurement range	0.2%~100%FS			
Test force measurement accuracy	±0.5% of indicating value			
Resolution of test force measurement	1/300000 of Max. test force (same resolution all the way)			
Deformation measurement range	0.2%~100%FS			
Deformation measurement accuracy	±0.5% of indicating value			
Deformation measurement resolution	1/200000 of Max. deformation, up to 1/300000			
Large deformation measurement range	10~800mm			
Large deformation measurement accuracy	±1% of indicating value			
Large deformation measurement resolution	8μm			
Displacement accuracy	±0.5% of indicating value			
Displacement resolution	0.01mm			
Force control speed adjustment range	0.005~5%FS/s			
Force control speed control accuracy	±2% of the set value (speed<0.05%FS/s) ±0.5% of the set value (speed≥0.05%FS/s)			
Deformation speed adjustment range	0.005~5%FS/s			
Deformation speed control accuracy	±2% of the set value (speed<0.05%FS/s) ±0.5% of the set value (speed≥0.05%FS/s)			
Beam displacement speed adjustment range	0.001~500mm/min			
Beam displacement speed control accuracy	±1% of the set value (speed<0.5mm/min) ±0.2% of the set value (speed≥0.5mm/min)			
Crosshead travel *	1030mm	970mm	1250mm	1000mm
Effective compression travel *	800mm	700mm	700mm	600mm
Horizontal test space *	400mm	440mm	600mm	550mm
Power supply	220V, 50Hz, 0.4kW~1kW		380V, 50Hz, 2kW~5kW	
Dimension	715×500×1680mm	820×620×1880mm	1070×855×2180mm	1070×920×2550mm
Weight	230kg	350kg	1000kg	1500kg

\* Can be customized according to test requirements

### STANDARD DELIVERY

Main unit	1 pc
Control box	1 pc
Computer	1 pc
Measuring software	1 pc
Printer	1 pc
Wedge tension fixture (including flat jaws and V-shaped jaws) **	1 set
Compression fixture	1 set
Extensometer (only for UTM-E100, UTM-E300)	1 pc

\*\* UTM-E10 does not have V-shaped jaws



V-shaped jaws (included)



flat jaws (included)



### OPTIONAL ACCESSORY

Extensometer	refer to details
Fixtures	refer to details

## SEMI-AUTOMATIC IMPACT TESTING MACHINES

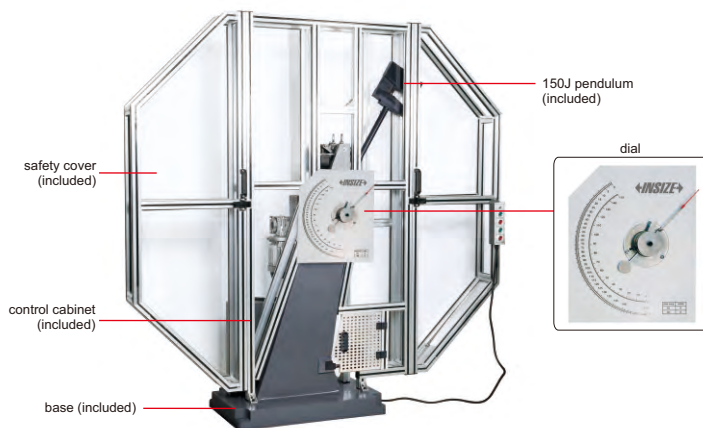

ITM-S150J



pendulum (included)



span aligner (included)



tongs (included)

### SPECIFICATION

Code	ITM-S150J	ITM-S300J
Impact energy	150J	300J
Dial range	0~150J	0~300J
Dial graduation	1J	2J
Pendulum moment	M=80.3848N·m	M=160.7695N·m
Pendulum preparing angle	150°	
Distance between pendulum shaft center and specimen center	750mm	
Impact speed	5.24m/s	
Span of specimen seat	40mm	
End face radius of specimen seat	R (1.0~1.5)mm	
Radius of impact blade	R (2.0~2.5)mm	
Inclination angle of support surface of specimen seat	11°±1°	
Angle of impact blade	30°±1°	
Thickness of impact blade	16mm	
Range of measuring angle	0~360°	
Angle resolution	≤0.06°	
Specimen size	10×10×55mm	
Power supply	AC 380V, 50Hz	
Base size	800×500mm	
Power	400W	
Dimension of main body	2050×690×2015mm	
Weight	450kg	

- According to ISO148
- For testing the anti-impact performance of metal materials under dynamic load
- High-precision bearings, small bearing friction, the impact absorption rate of empty pendulum is less than 0.3%
- Alloy steel impact blade, hardness HRC60
- PLC controller with built-in energy loss correction program
- Supplied with safety cover
- Supplied with software for data storage, automatic processing, etc.
- Data can be stored in Excel format, output and printed



software (included)

### STANDARD DELIVERY

Main unit		1 pc
Dial		1 pc
Control cabinet		1 pc
Pendulum	ITM-S150J	150J pendulum
	ITM-S300J	300J pendulum and 150J pendulum
Simply supported beam fixture (including jaws, anvil)		1 set
Computer		1 set
Printer		1 pc
Software		1 set
Span aligner		1 pc
Tongs		1 pc
Safety cover		1 set

### OPTIONAL ACCESSORY

Workbench	7911-15
150J pendulum	ITM-S-PE150J
300J pendulum	ITM-S-PE300J
ASTM standard impact blade	ITM-S-ASTM-IB
Sample recovery device	ITM-S-RD
Digital display screen	ITM-S-DDS



## UNIVERSAL PUSH AND PULL TESTING MACHINES



VIDEO

- Set force, set positioning and set deformation testing modes
- Protective functions of built-in mechanical limit, overload auto stop and emergency stop
- Dual-speed preset, high-speed approximation and low-speed acquisition
- Automatic back to start location after the test
- Can save 10 sets of test value and 3 sets of curve, test reports can be printed by built-in printer
- Display peak value, real-time value and process curve simultaneously
- Auto calibration of displacement zero
- Unit: lbf, N, kgf, ozf
- Auto power off (the time can be set)

### SPECIFICATION

Code	ISF-U055	ISF-U101	ISF-U202
Max. test force	500N	1000N	2000N
Resolution of force	0.05N	0.1N	0.2N
Test force measurement range	1%~100%FS		
Test force measurement accuracy	±1%FS (test force<10%FS) ±0.5%FS (test force≥10%FS)		
Range of adjustable speed	0.5~500mm/min		
Speed accuracy	±2%FS (speed<10%FS) ±1%FS (speed≥10%FS)		
Displacement resolution	0.001mm		
Displacement travel	300mm	450mm	450mm
Displacement accuracy	±0.4mm		
Unit	lbf, N, kgf, ozf		
Pressure plate size	Ø80mm		
Power supply	AC 220V, 50/60Hz		
Dimension	420×250×700mm	365×305×915mm	365×305×915mm
Weight	29.4kg	40kg	40kg



ISF-U202

### STANDARD DELIVERY

Main unit	1 pc
Adapter	2 pcs

## DIGITAL SPRING TESTERS

DATA OUTPUT

- Peak hold and automatic release function
- Set upper and lower limits, red and green indicator and buzzer alarm
- Automatic conversion of three units: N, kgf, lbf
- Built in printer
- Automatic power off



ISF-S500



VIDEO

### SPECIFICATION

Code	ISF-S50	ISF-S100	ISF-S200	ISF-S300	ISF-S500
Maximum load	50N	100N	200N	300N	500N
Resolution	0.01N	0.02N	0.05N	0.1N	0.1N
Range of digital scale	95mm				
Resolution of digital scale	0.01mm				
Disk diameter	Ø49mm				
Maximum free length of spring	95mm				
Measuring range of force	5%~100% (maximum load)				
Accuracy of force	±1% (maximum load)				
Data output	RS232				
Power supply	220V, 50/60Hz				
Dimension	300×235×620mm				
Weight	17.3kg	19.1kg	19.1kg	19.1kg	20.8kg

### STANDARD DELIVERY

Main unit	1 pc
-----------	------



## DIGITAL FORCE GAGES (HIGH ACCURACY)

- Push and pull test
- Peak (max.) and tracking mode
- Units: mN, N, gf, kgf, ozf, lbf
- Tolerance testing
- 1000 memories
- Automatic power off
- Metal case, touch buttons
- LCD display with backlight
- The display flips over when the bottom faces up
- Overload alarm
- Keyboard signal, can be transmitted to Excel



ISF-DF100A

### SPECIFICATION

Code	ISF-DF50A	ISF-DF100A	ISF-DF200A	ISF-DF500A	ISF-DF1KA
Type	internal sensor				
Load capacity (N)	50	100	200	500	1000
Resolution (N)	0.005	0.01	0.05	0.05	0.1
Accuracy	±0.2% (of load capacity)				
Power supply	built-in rechargeable battery				

### STANDARD DELIVERY

Main unit	1 pc
AC/DC adapter	1 pc
Software and USB cable	1 pc
Push/pull accessory	6 pcs (flat push tip, V-type push tip, knife-edge push tip, point push tip, pull clamp, extension rod)

### OPTIONAL ACCESSORY

Printer	ISF-DF-PRINTER
Test stand	ISF-MT1K

printer (optional)



software flash disk (included)

accessory (included)

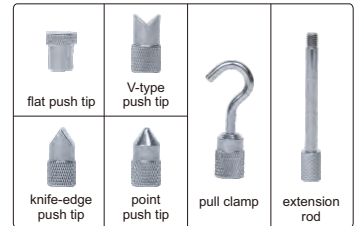

## DIGITAL FORCE GAGES



- Push and pull test
- Units: lbf, ozf, N, gf, kgf
- 500 memories
- Automatic power off
- Metal case
- LCD display with backlight
- The display flips over when the bottom faces up
- Overload alarm



ISF-1DF100

### SPECIFICATION

Code	ISF-1DF10	ISF-1DF50	ISF-1DF100	ISF-1DF500	ISF-1DF1000
Load capacity (N)	10	50	100	500	1000
Resolution (N)	0.01	0.01	0.1	0.1	1
Accuracy	±0.3% (of load capacity)				
Measuring mode	tracking, peak (max.), tolerance testing				
Power supply	built-in rechargeable battery				
Dimension	150×73×33mm				
Weight	450g				

### STANDARD DELIVERY

Main unit	1 pc
AC/DC adapter	1 pc
Software and USB cable	1 pc
Push/pull accessory	6 pcs (flat push tip, V-type push tip, knife-edge push tip, point push tip, pull clamp, extension rod)

printer (optional)



software flash disk (included)



accessory (included)

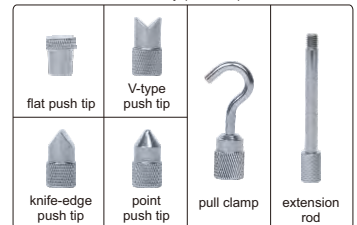

### OPTIONAL ACCESSORY

Printer	ISF-DF-PRINTER
Test stand	ISF-MT1K

## TEST STAND FOR DIGITAL FORCE GAGE CODE ISF-MT1K

- For digital force gages (code **ISF-1DF**□□ and **ISF-DF**□□)
- To be used in vertical and horizontal orientation

### SPECIFICATION

Load capacity	1000N
Travel	200mm (3mm vertical movement per revolution of handwheel)
Dimension	196x250x446mm
Weight	13kg

### OPTIONAL ACCESSORY

Digital scale (range: 200mm, resolution: 0.01mm/0.0005")	ISF-MT1K-SCALE
--	----------------

force gage  
is optional



digital scale (optional)

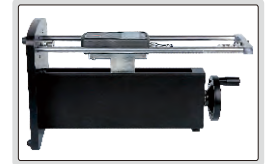

horizontal orientation test

## FORCE GAGES

- Push and pull test
- Peak (max.) or tracking mode



ISF-F500



### SPECIFICATION

Code		ISF-F10	ISF-F20	ISF-F30	ISF-F50	ISF-F100	ISF-F200	ISF-F300	ISF-F500
Capacity	N	10	20	30	50	100	200	300	500
	kgf	1	2	3	5	10	20	30	50
Graduation	N	0.05	0.1	0.2	0.25	0.5	1	2	2.5
Accuracy		±1% (of load capacity)							

### STANDARD DELIVERY

Main unit	1 pc
Push tip	4 pcs (flat, V type, knife-edge, point)
Pull clamp	1 pc
Extension rod	1 pc

### OPTIONAL ACCESSORY

Test stand	ISF-MT500
------------	-----------

accessory (included)

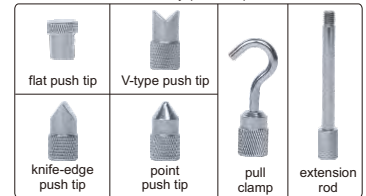

## TEST STAND FOR FORCE GAGE CODE ISF-MT500

- For force gages (code **ISF-F**□□□)
- To be used in vertical and horizontal orientation

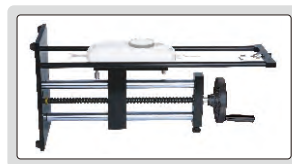

horizontal orientation test

force gage  
is optional



### SPECIFICATION

Load capacity	500N
Travel	150mm (3mm vertical movement per revolution of handwheel)
Dimension	160x240x460mm
Weight	12kg

## MANUAL HORIZONTAL TEST STAND FOR FORCE GAGES



VIDEO

ATTENTION: ONLY FOR PULL TEST

force gage is optional

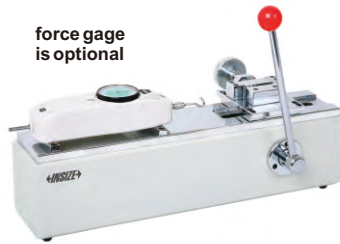

- For pull test with force gages

### SPECIFICATION

Code	ISF-H20D
Apply to	digital force gages (code ISF-1DF□□□ and ISF-DF□□□)
Load capacity	500N
Travel	60mm
Dimension	450×185×170mm
Weight	9kg

## MANUAL STRIPPING FORCE TEST STAND



VIDEO

force gage is optional

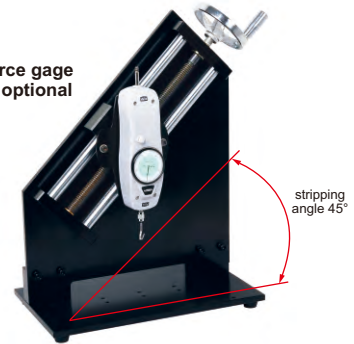

- For stripping force test with force gages

### SPECIFICATION

Code	ISF-P30D
Apply to	digital force gages (code ISF-1DF□□□ and ISF-DF□□□)
Load capacity	500N
Horizontal travel	170mm
Dimension	420×215×480mm
Weight	22kg

## MOTORIZED VERTICAL TEST STAND CODE ISF-RV61



VIDEO

digital force gage is optional



- For digital force gages (code ISF-1DF□□□ and ISF-DF□□□)
- Push and pull test
- Automatic and manual test
- Programmable automatic operation (automatic cycle)
- Four operation modes: displacement cycle (D cycle), force cycle (F cycle), demo (teaching & playback) mode and positioning mode
- Alarm indications: stroke overrange alarm, force overrange alarm, motor block alarm

### SPECIFICATION

Load capacity	650N (250lbf, 65kg)
Max. travel	220mm
Resolution of displacement	0.01mm
Accuracy of displacement	±0.3mm
Range of adjustable speed	30~720mm/min
Resolution of speed	1mm/min
Accuracy of speed	±2%
Data output	USB, RS232
Work temperature and relative humidity	10~40°C, 10%~80%RH
Power supply	100~230V
Dimension	340×180×630mm
Weight	15.5kg

### STANDARD DELIVERY

Test stand	1 pc
AC/DC adapter	1 pc
MD8 cable (for force gages)	1 pc
Software and USB cable	1 pc

## MOTORIZED HORIZONTAL TEST STAND CODE ISF-RH62



VIDEO

digital force gage is optional

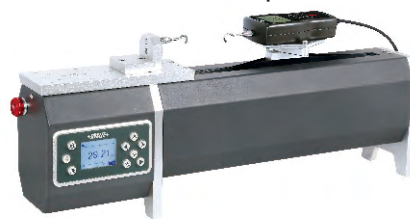

- For digital force gages (code ISF-1DF□□□ and ISF-DF□□□)
- Push and pull test
- Automatic and manual test
- Programmable automatic operation (automatic cycle)
- Four operation modes: displacement cycle (D cycle), force cycle (F cycle), demo (teaching & playback) mode and positioning mode
- Alarm indications: stroke overrange alarm, force overrange alarm, motor block alarm

### SPECIFICATION

Load capacity	650N (250lbf, 65kg)
Max. travel	220mm
Resolution of displacement	0.01mm
Accuracy of displacement	±0.3mm
Range of adjustable speed	30~720mm/min
Resolution of speed	1mm/min
Accuracy of speed	±2%
Data output	USB, RS232
Work temperature and relative humidity	10~40°C, 10%~80%RH
Power supply	100~230V
Dimension	671×120×278mm
Weight	13kg

### STANDARD DELIVERY

Test stand	1 pc
AC/DC adapter	1 pc
MD8 cable (for force gages)	1 pc
Software and USB cable	1 pc

## DIAL TENSION GAGES

- Clockwise and counter-clockwise use
- For electronic and precision mechanical industry, such as test the contact pressure of relay, adjust the tension or compression of spring

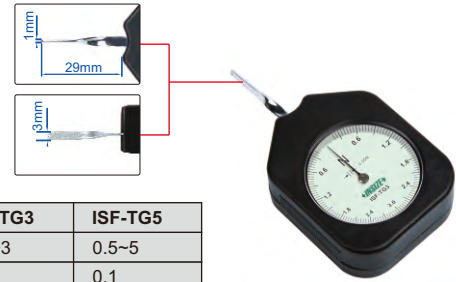

ISF-TG3

### SPECIFICATION (Unit: N)

Code	ISF-TGD1	ISF-TGD3	ISF-TGD5	ISF-TG1	ISF-TG1D5	ISF-TG3	ISF-TG5
Range (N)	0.01~0.1	0.03~0.3	0.05~0.5	0.1~1	0.15~1.5	0.3~3	0.5~5
Graduation (N)	0.002	0.005	0.01	0.02	0.025	0.05	0.1
Accuracy	±2% (full scale)						
Dimension (L×W×H)	90×47×19mm						
Weight	60g						

### SPECIFICATION (Unit: gf)

Code	ISF-TG10	ISF-TG30	ISF-TG50	ISF-TG100	ISF-TG150	ISF-TG300	ISF-TG500
Range (gf)	1~10	3~30	5~50	10~100	15~150	30~300	50~500
Graduation (gf)	0.2	0.5	1	2	2.5	5	10
Accuracy	±2% (full scale)						
Dimension (L×W×H)	90×47×19mm						
Weight	60g						

## DIGITAL TORQUE TESTERS

**ATTENTION: NOT SUITABLE FOR ELECTRIC WRENCHES, IMPACT WRENCHES OR PNEUMATIC WRENCHES**

- Test torque wrenches, torque screwdrivers and other torque tools
- Clockwise operation
- Peak, track and first peak working modes
- Tolerance testing
- LED indicator for target torque alarm:
  - Green LED light on when the value is within tolerance;
  - Red LED light on when the value is above the high tolerance
- Power off automatically in 2 minutes without any operations



IST-04TT350  
type A



IST-04TT815  
type B

### SPECIFICATION

Code	IST-04TT5	IST-04TT28	IST-04TT68	IST-04TT350	IST-04TT815	IST-04TT1000
Type	A				B	
Range	0.5~5N.m	2.8~28N.m	6.8~68N.m	35~350N.m	81.5~815N.m	100~1000N.m
Accuracy	±1% (clockwise)					
Resolution	0.001N.m	0.01N.m	0.01N.m	0.1N.m	0.1N.m	1N.m
Unit	N.m, in.lb, ft.lb, kg.cm					N.m, ft.lb
Square socket/hex driver	1/4"	3/8"	3/8"	1/2"	27mm	27mm
Adaptor	no	3/8" to 1/4"	3/8" to 1/4"	1/2" to 3/8" 3/8" to 1/4"	no	
Power supply	DC					
Weight	0.75kg	0.75kg	1.1kg	1.1kg	5.1kg	5.1kg



adaptor  
(type A included)



### STANDARD DELIVERY

Main unit	1 pc
AC/DC adapter	1 pc
Adaptor	refer to details

## TORQUE SCREWDRIVERS

**ATTENTION: CLOCKWISE OPERATION ONLY**



T-bar wrench  
(for IST-MG250,  
IST-MG360, IST-MG600)



IST-MG100

### SPECIFICATION

Code	IST-MG100	IST-MG250	IST-MG360	IST-MG600
Range (clockwise)	20~100cN.m	50~250cN.m	60~360cN.m	1.0~6.0N.m
Graduation	2cN.m	5cN.m	5cN.m	0.1N.m
Head	1/4" hex socket			
Accuracy	±6%			
Length	172mm			
Weight	0.26kg			

### STANDARD DELIVERY

Torque screwdriver	1 pc
T-bar wrench (for IST-MG250, IST-MG360, IST-MG600)	1 pc

## DIGITAL TORQUE SCREWDRIVERS



- Clockwise and counter-clockwise operation
- Unit: cN.m, in.lb, kg.cm
- Peak and track working modes
- Target torque value can be set, with audible and visible alarm:
  - Green LED light on and buzzer sounds when target torque value is 90%~100% of target torque
  - Red LED light on and buzzer sounds when target torque value is reached
- Power off automatically in 5 minutes without any operations

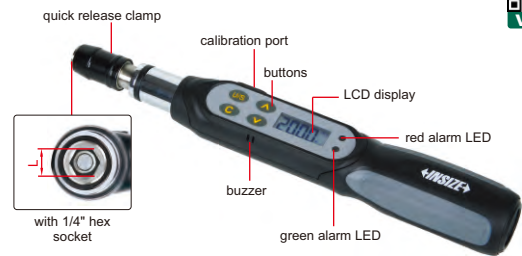

IST-SD200

### SPECIFICATION

Code	IST-SD50	IST-SD200
Range	10~50cN.m	40~200cN.m
Accuracy	clockwise	±3%
	counter-clockwise	±4%
Resolution	0.1cN.m	0.1cN.m
Size of hex socket (L)	1/4"	1/4"
Power supply	1xAAA battery	
Length	193mm	203mm
Weight	190g	200g

### STANDARD DELIVERY

Torque screwdriver	1 pc
Phillips screwdriver bits	1 pc
Hex screwdriver bits	1 pc



hex screwdriver bits (included)



phillips screwdriver bits (included)

### OPTIONAL ACCESSORY

Calibration cable	IST-SD-CABLE
-------------------	--------------

## DIGITAL TORQUE WRENCHES

OPTIONAL ACCURACY:  
CLOCKWISE: ±1%  
COUNTER-CLOCKWISE: ±2%  
ONLY FOR RANGE 6~850N.m



- Clockwise and counter-clockwise operation
- Unit: N.m, in.lb, ft.lb, kg.cm
- Peak and track working mode
- Target torque value can be set, with audible and visible alarm:
  - Green LED light on and buzzer sounds when torque value is 90%~100% of target torque
  - Both green and red LED light on and buzzer sounds when target torque value is reached
- Power off automatically in 5 minutes without any operations
- Non-slip grip handle
- With damp record
- With overload record (once the torque reaches 110% of the maximum range)

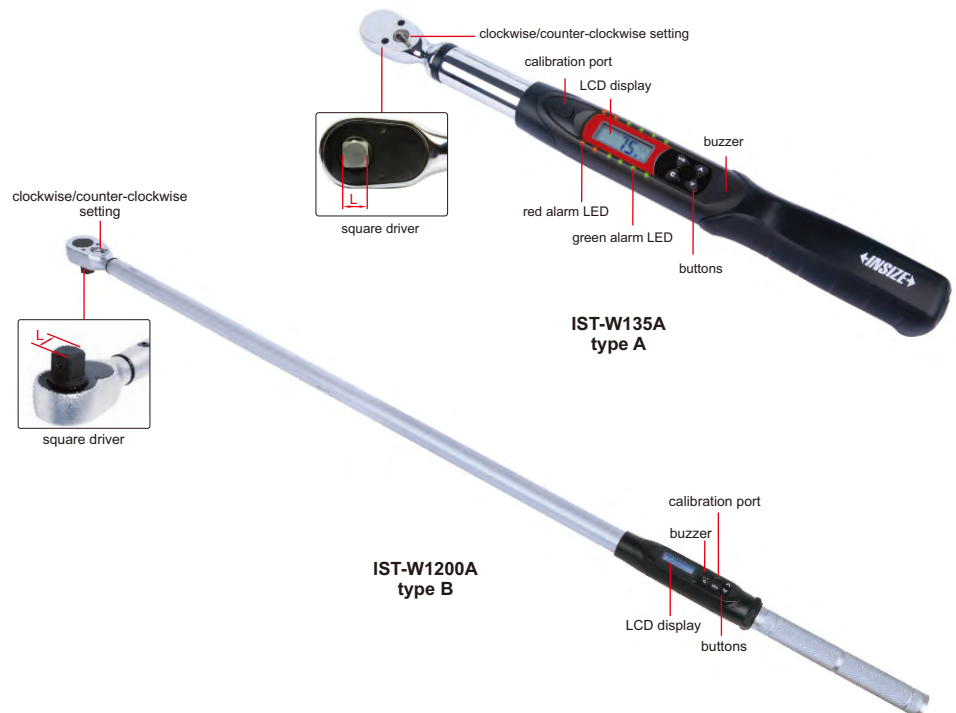

IST-W135A type A

IST-W1200A type B

### SPECIFICATION

Code	Type	Range	Accuracy	Resolution	Square driver (L)	Power supply	Length	Weight
IST-W30A	A	6~30N.m	clockwise: ±2% counter-clock wise: ±3%	0.01N.m	1/4"	2×AA batteries, for 110 hours working	390mm	830g
IST-W135A		27~135N.m		0.1N.m	3/8"		415mm	950g
IST-W200A		40~200N.m		0.1N.m	1/2"		530mm	1.4kg
IST-W340A		68~340N.m		0.1N.m	1/2"		650mm	1.6kg
IST-W500A *	B	100~500N.m	clockwise: ±2.5% counter-clock wise: ±3.5%	0.1N.m	3/4"		1285mm	7kg
IST-W850A		170~850N.m		0.1N.m	3/4"		1295mm	6kg
IST-W1200A		240~1200N.m		1N.m	1"		1920mm	13kg
IST-W1500A		300~1500N.m		1N.m	1"		1920mm	13kg
IST-W2000A		400~2000N.m		1N.m	1"		1920mm	14kg

\* The accuracy of this code is not optional

### OPTIONAL ACCESSORY

Calibration cable	IST-W-CABLE
-------------------	-------------

## INTERCHANGEABLE HEAD TORQUE WRENCHES

ATTENTION: CLOCKWISE OPERATION ONLY



- According to DIN ISO 6789, ASME B107.300
- All-metal construction, sturdy and durable

### SPECIFICATION

Code	Range (clockwise)	Accuracy	Graduation	Socket size (A×B)	Length	Weight
IST-11WM12	2.5~12N.m	±6% (<10N.m) ±4% (≥10N.m)	0.05N.m	12×9mm	284mm	580g
IST-11WM30	6.0~30N.m	±6% (<10N.m) ±4% (≥10N.m)	0.1N.m	12×9mm	303mm	720g
IST-11WM60	10~60N.m	±4%	0.5N.m	12×9mm	372mm	860g
IST-11WM125	25~125N.m	±4%	0.5N.m	12×9mm	427mm	940g
IST-11WM200	40~200N.m	±4%	1N.m	18×14mm	460mm	1060g
IST-11WM335	65~335N.m	±4%	1N.m	18×14mm	520mm	1200g

### RATCHET HEAD (optional)



Code	Square driver	Applicable wrenches
IST-11WM-R1	1/4"	IST-11WM12, IST-11WM30
IST-11WM-R2	3/8"	IST-11WM12, IST-11WM30 IST-11WM60, IST-11WM125
IST-11WM-R3	1/2"	IST-11WM200, IST-11WM335
IST-11WM-R4*	3/4"	IST-11WM200, IST-11WM335



### HOOK HEAD (optional)

Hook head	customized according to customer requirements
-----------	---



### OPEN END HEAD (optional)

Code	Open size	Applicable wrenches
IST-11WM-K8	8mm	IST-11WM12 IST-11WM30 IST-11WM60 IST-11WM125
IST-11WM-K10	10mm	
IST-11WM-K13	13mm	
IST-11WM-K14	14mm	
IST-11WM-K15	15mm	
IST-11WM-K17	17mm	
IST-11WM-K19*	19mm	
IST-11WM-K13A	13mm	IST-11WM200 IST-11WM335
IST-11WM-K14A	14mm	
IST-11WM-K15A	15mm	
IST-11WM-K17A	17mm	
IST-11WM-K19A	19mm	
IST-11WM-K22A	22mm	
IST-11WM-K24A	24mm	
IST-11WM-K27A*	27mm	
IST-11WM-K30A*	30mm	
IST-11WM-K32A*	32mm	

### BOX END HEAD (optional)

Code	Open size	Applicable wrenches
IST-11WM-M8	8mm	IST-11WM12 IST-11WM30 IST-11WM60 IST-11WM125
IST-11WM-M10	10mm	
IST-11WM-M13	13mm	
IST-11WM-M14	14mm	
IST-11WM-M15	15mm	
IST-11WM-M17	17mm	
IST-11WM-M19	19mm	
IST-11WM-M13A	13mm	IST-11WM200 IST-11WM335
IST-11WM-M14A	14mm	
IST-11WM-M15A	15mm	
IST-11WM-M17A	17mm	
IST-11WM-M19A	19mm	
IST-11WM-M22A	22mm	
IST-11WM-M24A	24mm	
IST-11WM-M27A	27mm	
IST-11WM-M30A	30mm	
IST-11WM-M32A	32mm	

\*Torque value needs to be corrected with those heads

TORQUE WRENCHES



ATTENTION: CLOCKWISE OPERATION ONLY

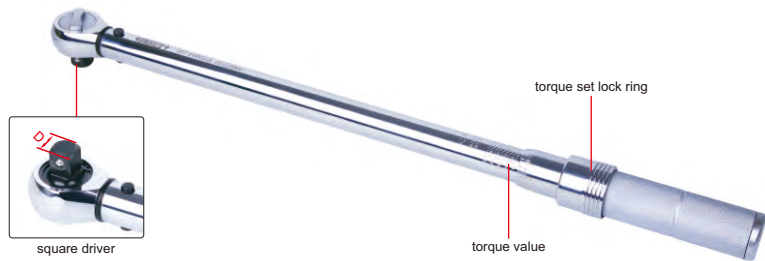

IST-9WM335

- According to DIN ISO 6789, ASME B107.300
- All-metal construction, sturdy and durable

SPECIFICATION

Code	IST-9WM12	IST-9WM20	IST-9WM30	IST-9WM60	IST-9WM100	IST-9WM125	IST-9WM200
Range (clockwise)	2.5~12N.m	4~20N.m	6~30N.m	10~60N.m	20~100N.m	25~125N.m	40~200N.m
Accuracy	±6% (<10N.m) ±4% (≥10N.m)	±6% (<10N.m) ±4% (≥10N.m)	±6% (<10N.m) ±4% (≥10N.m)	±4%	±4%	±4%	±4%
Graduation	0.1N.m	0.1N.m	0.2N.m	0.5N.m	0.5N.m	0.5N.m	1N.m
Square driver (D)	1/4"	1/4"	3/8"	3/8"	1/2"	1/2"	1/2"
Length	290mm	290mm	318mm	388mm	443mm	443mm	468mm
Weight	680g	680g	820g	960g	1040g	1040g	1160g

Code	IST-9WM335	IST-9WM500	IST-9WM800	IST-9WM1000	IST-9WM1500	IST-9WM2000	IST-9WM3000
Range (clockwise)	65~335N.m	100~500N.m	160~800N.m	200~1000N.m	300~1500N.m	400~2000N.m	600~3000N.m
Accuracy	±4%	±4%	±4%	±4%	±4%	±4%	±4%
Graduation	1N.m	2.5N.m	4N.m	5N.m	5N.m	10N.m	15N.m
Square driver (D)	1/2"	3/4"	3/4"	3/4"	1"	1"	1"
Length	528mm	855mm	1055mm	1055mm	1260mm	1260mm	1260mm
Weight	1300g	5000g	5900g	5900g	9200g	9200g	10500g

MECHANICAL TORQUE WRENCHES (DIGITAL SETTING)



ATTENTION: CLOCKWISE OPERATION ONLY

ATTENTION: DISPLAY PRE-SET TORQUE VALUE (NOT REAL TIME TORQUE)



IST-19WM100

- Unit: N.m, in.lb, ft.lb, kg.cm
- Mechanical "click" torque wrench, the pre-set torque value is shown on the display

SPECIFICATION

Code	IST-19WM60	IST-19WM100	IST-19WM140	IST-19WM200	IST-19WM300
Range (clockwise)	6~60N.m	10~100N.m	14~140N.m	20~200N.m	30~300N.m
Accuracy	±3%	±3%	±3%	±3%	±3%
Graduation	0.1N.m	0.1N.m	0.1N.m	0.1N.m	0.1N.m
Square driver (D)	3/8"	3/8"	1/2"	1/2"	1/2"
Length	382mm	450mm	481mm	520mm	585mm
Weight	1.3kg	1.4kg	1.45kg	1.6kg	1.8kg



## PRESET TORQUE WRENCHES

ATTENTION: CLOCKWISE OPERATION ONLY

- Torque is preset, to prevent adjustment by mistake during use
- The torque is set at the factory before delivery. Customers can also set the torque with torque adjustment tool (IST-PW-TOOL, optional) and digital torque testers (IST-TT□□□, optional)
- Clockwise operation only



IST-PW60



torque adjustment tool (optional)

### SPECIFICATION

Code	IST-PW12	IST-PW20	IST-PW30	IST-PW60	IST-PW125	IST-PW200
Adjustable range *	2.5~12N.m 22~105in.lb	4~20N.m 36~175in.lb	6~30N.m 55~265in.lb	10~60N.m 8~44ft.lb	25~125N.m 20~90ft.lb	40~200N.m 30~145ft.lb
Accuracy	±3%	±3%	±3%	±3%	±3%	±3%
Square driver (D)	1/4"	1/4"	3/8"	3/8"	3/8"	1/2"
Length	184mm	184mm	214mm	255mm	366mm	457mm
Weight	450g	450g	500g	560g	790g	1200g

Code	IST-PW340	IST-PW500	IST-PW650	IST-PW800	IST-PW1000A	IST-PW1000B
Adjustable range *	65~340N.m 50~250ft.lb	100~500N.m 75~365ft.lb	150~650N.m 110~475ft.lb	160~800N.m 120~585ft.lb	200~1000N.m 150~735ft.lb	200~1000N.m 150~735ft.lb
Accuracy	±3%	±3%	±4%	±4%	±4%	±4%
Square driver (D)	1/2"	3/4"	3/4"	3/4"	3/4"	1"
Length	691mm	910mm	910mm	1037mm	1265mm	1265mm
Weight	1960g	2800g	2800g	5000g	6000g	6000g

\* Adjust to a fixed torque value according to customer requirements before delivery

### OPTIONAL ACCESSORY

Torque adjustment tool    IST-PW-TOOL

## DIAL TORQUE WRENCHES



- Clockwise and counter-clockwise operation
- According to DIN ISO 6789, ASME B107.300

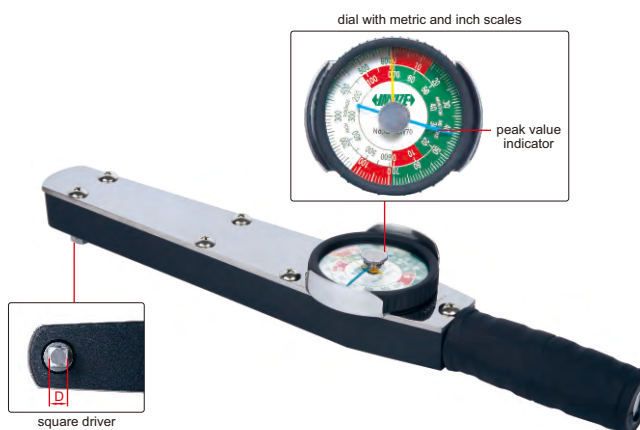

IST-DW70

### SPECIFICATION

Code	IST-DW18	IST-DW35	IST-DW70	IST-DW140
Range	3.6~18N.m 30~150in.lb	7~35N.m 60~300in.lb	14~70N.m 120~600in.lb	28~140N.m 20~100ft.lb
Accuracy	±3%	±3%	±3%	±3%
Graduation	0.2N.m 2in.lb	0.5N.m 5in.lb	1N.m 10in.lb	2N.m 1ft.lb
Square driver (D)	3/8"	3/8"	3/8"	1/2"
Length	254mm	254mm	378mm	546mm
Weight	480g	480g	820g	1300g

## ELECTRONIC BALANCES (0.1mg)



DATA OUTPUT



calibration weight  
(included in 8310-120M,  
8310-210M and 8310-320M)



printer (optional)



8310-320A

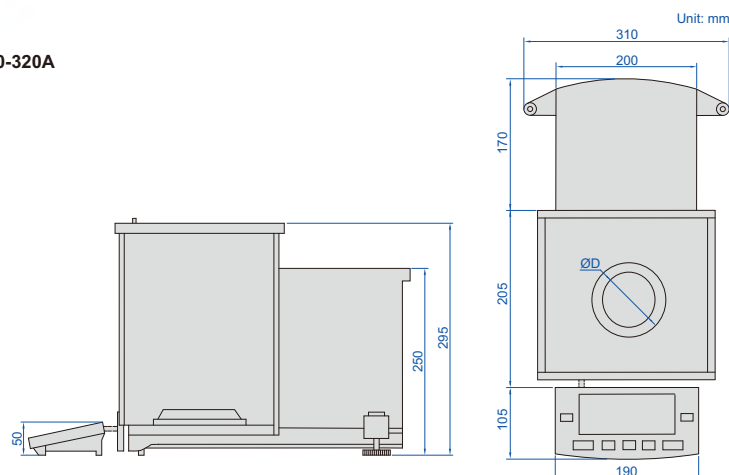

- Rear electromagnetic sensor
- Separated display unit and weighing unit, reduce vibration error
- Digital processing technology improves reading stability and response speed for micro sample addition, sample weight and balance reading is consistent
- Unit: g, oz, ct, lb
- Weighing, counting, taring, percentage
- Data output

### SPECIFICATION

Code	8310-120M	8310-210M	8310-320M	8310-120A	8310-210A	8310-320A
Calibration	external calibration			internal calibration		
Maximum weighing	120g	210g	320g	120g	210g	320g
Minimum weighing	10mg	10mg	10mg	10mg	10mg	10mg
Resolution (d)	0.1mg	0.1mg	0.1mg	0.1mg	0.1mg	0.1mg
Verification interval (e)	1mg	1mg	1mg	1mg	1mg	1mg
Accuracy (m is load)	m≤50g: ±0.5mg; 50g<m≤200g: ±1mg; m>200g: ±1.5mg			m≤50g: ±0.5mg; 50g<m≤200g: ±1mg; m>200g: ±1.5mg		
Repeatability	±0.1mg					
Linearity	±0.1mg					
Stabilization time	2.5s					
Weighing pan size (ØD)	Ø90mm					
Output	RS232					
Operation temperature	10~30°C					
Operation humidity	20~85% RH					
Power supply	power adapter (12V/2A)					
Dimension (L×W×H)	480×310×320mm					
Weight	6kg					

### OPTIONAL ACCESSORY

RS232 cable	8304-CABLE *
Printer	8303-PRINTER

\*Used to connect with computers

## ELECTRONIC BALANCES (0.1mg)

DATA  
OUTPUT

- Electromagnetic sensor
- Unit: g, ct, oz, lb
- Weighing, counting, taring
- Data output

### SPECIFICATION

Code	8304-120	8304-220
Maximum weighing	120g	220g
Minimum weighing	10mg	10mg
Resolution (d)	0.1mg	0.1mg
Verification interval (e)	1mg	1mg
Accuracy (m is load)	m≤50g: ±0.5mg; 50g<m≤120g: ±1mg	m≤50g: ±0.5mg; 50g<m≤200g: ±1mg; m>200g: ±1.5mg
Weighing pan size (ØD)	Ø90mm	
Operation temperature	10~30°C	
Operation humidity	20~85% RH	
Power supply	power adapter (12V/2A)	
Dimension (L×W×H)	230×310×320mm	



8304-120



calibration weight (included)



printer (optional)

### OPTIONAL ACCESSORY

RS232 cable	8304-CABLE*
Printer	8303-PRINTER
Data output cable (keyboard format)	7302-8304

\*Used to connect with computers

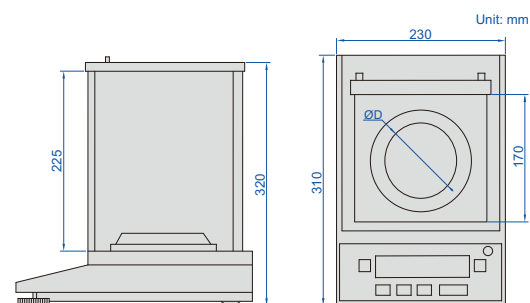

## ELECTRONIC BALANCES (1mg)

DATA  
OUTPUT

- Aluminum alloy shell, wind shield, three side glass sliding doors
- Electromagnetic balance sensor
- Unit: g, ct, ozt, oz, gn, dwt, mg
- Weighing, counting, taring
- Data output
- With a hook at the bottom



8303-520



printer (optional)



calibration weight (included)

### SPECIFICATION

Code	8303-220	8303-320	8303-520	8303-620	8303-1020
Maximum weighing	220g	320g	520g	620g	1020g
Minimum weighing	20mg	20mg	100mg	100mg	100mg
Resolution (d)	1mg	1mg	1mg	1mg	1mg
Verification interval (e)	10mg	10mg	10mg	10mg	10mg
Accuracy	load capacity≤500g: ±5mg; load capacity>500g: ±10mg				
Weighing pan size (ØD)	Ø80mm				Ø120mm
Operation temperature	15~30°C		18~23°C		
Operation humidity	40%~80% RH		50%~70% RH		
Power supply	220V, 50/60Hz				
Dimension (L×W×H)	330×210×340mm				

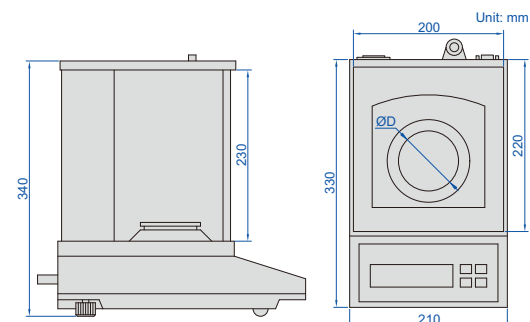

### OPTIONAL ACCESSORY

RS232 cable	8301-CABLE*
Printer	8303-PRINTER

\*Used to connect with computers

**ELECTRONIC BALANCES (0.01g)**

DATA OUTPUT



8305-5000

- LCD with back light
- Unit: g, ct, ozt, oz, GN, dwt, lb, kg
- Weighing, counting, taring

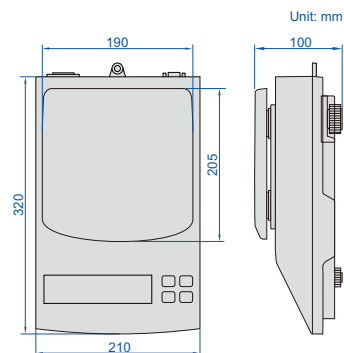

**SPECIFICATION**

Code	8305-2000	8305-3000	8305-5000	8305-6000
Maximum weighing	2kg	3kg	5kg	6kg
Minimum weighing	0.2g	0.2g	0.2g	0.2g
Resolution (d)	0.01g	0.01g	0.01g	0.01g
Verification interval (e)	0.1g	0.1g	0.1g	0.1g
Accuracy (m is load)	m≤0.5kg: ±0.05g; 0.5kg<m≤2kg: ±0.1g	m≤0.5kg: ±0.05g; 0.5kg<m≤2kg: ±0.1g m>2kg: ±0.15g	m≤0.5kg: ±0.05g; 0.5kg<m≤2kg: ±0.1g m>2kg: ±0.15g	m≤0.5kg: ±0.05g; 0.5kg<m≤2kg: ±0.1g m>2kg: ±0.15g
Weighing pan size	190×205mm			
Output	RS232			
Operation temperature	0~40°C			
Operation humidity	≤80% RH			
Power supply	220V, 50/60Hz			
Dimension (L×W×H)	320×210×100mm			



calibration weight (included in 8305-2000 and 8305-3000)



printer (optional)

**OPTIONAL ACCESSORY**

RS232 cable	8301-CABLE*
Printer	8303-PRINTER
Data output cable (keyboard format)	7302-8001
Wireless transmitter (need receiver)	7315-8301

\*Used to connect with computers

**ELECTRONIC BALANCES**

DATA OUTPUT

- Automatic zero when power on
- Unit: g (gram), ct (carat), ozt (troy ounce)
- Weighing, counting, taring
- Overload alarm
- Data output



8301-3000

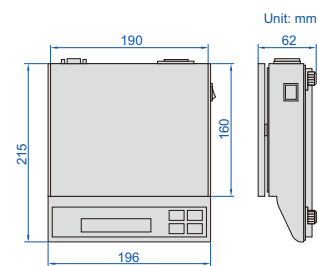

**SPECIFICATION**

Code	8301-300	8301-600	8301-1200	8301-3000	8301-6000
Maximum weighing	300g	600g	1200g	3000g	6000g
Minimum weighing	0.2g	0.2g	0.2g	2g	2g
Resolution (d)	0.01g	0.01g	0.01g	0.1g	0.1g
Verification interval (e)	0.1g	0.1g	0.1g	1g	1g
Accuracy (m is load)	m≤50g: ±0.05g; 50g<m≤200g: ±0.1g; m>200g: ±0.15g		m≤500g: ±0.5g; 500g<m≤2000g: ±1g; m>2000g: ±1.5g		
Weighing pan size	Ø135mm		190×160mm		
Operation temperature	0~40°C				
Operation humidity	≤80% RH				
Power supply	220V, 50/60Hz				
Dimension (L×W×H)	215×196×62mm				



windshield (included in 8301-300, 8301-600 and 8301-1200)



calibration weight (included in 8301-300, 8301-600 and 8301-1200)

**OPTIONAL ACCESSORY**

RS232 cable	8301-CABLE
Data output cable (keyboard format)	7302-8001
Wireless transmitter (need receiver)	7315-8301

## WEIGHING SCALES (OIML CERTIFICATE)

- LCD display, with backlight
- Zero-setting, subtracting tare value
- Overload alarm
- Automatic power off
- OIML certificate (No. 0200-NAWI-04601)



8002-30M

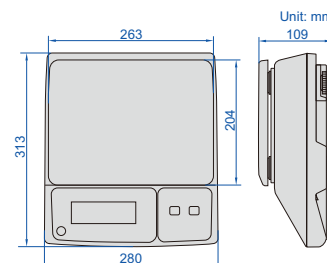

### SPECIFICATION

Code	8002-6M	8002-15M	8002-30M
Maximum capacity	3/6kg	6/15kg	15/30kg
Minimum capacity	20g	40g	100g
Resolution (d)	1/2g	2/5g	5/10g
Verification interval (e)	2g	5g	10g
Accuracy (m is load)	m≤3kg: ±1g 3kg<m≤6kg: ±2g	m≤6kg: ±2g 6kg<m≤15kg: ±5g	m≤15kg: ±5g 15kg<m≤30kg: ±10g
Operation temperature	-10~40°C		
Power	rechargeable battery (6V/3.2Ah), power adapter (12V/500mA)		
Dimensions of pan	263×204mm		

## WEIGHING SCALES (HIGH PRECISION)

- LCD display, with backlight
- Zero-setting, subtracting tare value
- Overload alarm
- Automatic power off

### SPECIFICATION

Code	8001-6	8001-15	8001-30
Maximum weighing	6kg	15kg	30kg
Minimum weighing	4g	10g	20g
Resolution (d)	0.2g	0.5g	1g
Accuracy (m is load)	m≤1kg: ±1g 1kg<m≤4kg: ±2g m>4kg: ±3g	m≤2.5kg: ±2.5g 2.5kg<m≤10kg: ±5g m>10kg: ±7.5g	m≤5kg: ±5g 5kg<m≤20kg: ±10g m>20kg: ±15g
Units	kg, lb		
Operation temperature	-10~40°C		
Power	rechargeable battery (6V/3.2Ah), power adapter (12V/500mA)		
Dimensions of pan	263×204mm		



8001-30

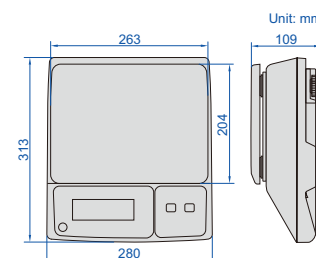

## COUNTING SCALES

- LCD display, with backlight
- Zero-setting, subtracting tare value, counting, accumulation, checking alarm
- Overload alarm
- Units: kg, g, lb, tj, hj, lb-oz

### SPECIFICATION

Code	8101-6	8101-15	8101-30
Maximum weighing	6kg	15kg	30kg
Minimum weighing	4g	10g	20g
Resolution (d)	0.2g	0.5g	1g
Accuracy (m is load)	m≤1kg: ±1g 1kg<m≤4kg: ±2g m>4kg: ±3g	m≤2.5kg: ±2.5g 2.5kg<m≤10kg: ±5g m>10kg: ±7.5g	m≤5kg: ±5g 5kg<m≤20kg: ±10g m>20kg: ±15g
Operation temperature	-10~40°C		
Power	rechargeable battery (6V/3.2Ah), power adapter (12V/500mA)		
Dimensions of pan	263×204mm		



8101-30

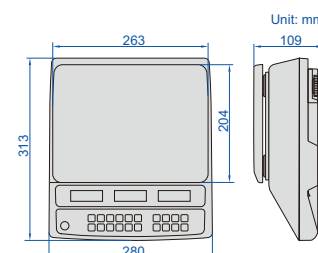

**ELECTRONIC POCKET SCALE  
(ECONOMIC TYPE)**

ATTENTION:  
LOW ACCURACY



8601-100

- LCD display, with backlight
- Zero-setting, subtracting tare value, counting
- Overload alarm
- Automatic power off



use of pan

**SPECIFICATION**

Code	8601-100
Maximum weighing	100g
Minimum weighing	0.1g
Resolution (d)	0.01g
Accuracy (m is load)	0.1g≤m≤1g: ±0.03g; 1g<m≤30g: ±0.05g 30g<m≤50g: ±0.07g; m>50g: ±0.14g
Units	g, oz, dwt, ozt
Dimension of pan	55×64mm
Dimension (L×W×H)	108×65×21mm
Operation temperature	-10~40°C
Power supply	2×AAA batteries

**ELECTRONIC POCKET SCALE  
(ECONOMIC TYPE)**

ATTENTION:  
LOW ACCURACY



8602-200

- LCD display, with backlight
- Zero-setting, subtracting tare value, counting
- Overload alarm
- Automatic power off



use of pan

**SPECIFICATION**

Code	8602-200
Maximum weighing	200g
Minimum weighing	0.2g
Resolution (d)	0.02g
Accuracy (m is load)	0.2g≤m≤2g: ±0.06g; 2g<m≤60g: ±0.1g 60g<m≤100g: ±0.14g; m>100g: ±0.28g
Units	g, oz, dwt, ozt
Dimension of pan	55×64mm
Dimension (L×W×H)	120×70×17mm
Operation temperature	-10~40°C
Power supply	2×CR2032 batteries

**PLATFORM SCALES**

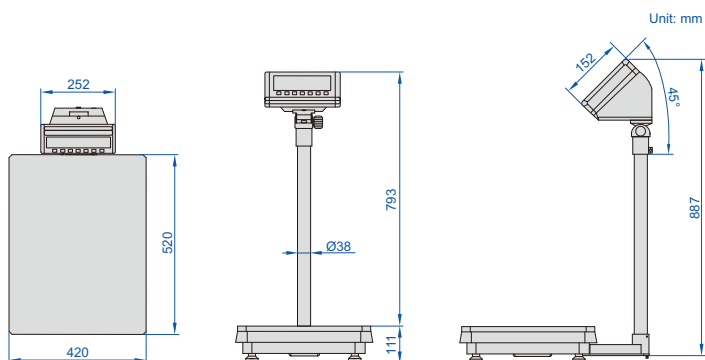

**SPECIFICATION**

Code	8501-AL60	8501-AL150	8501-AL300
Maximum weighing	60kg	150kg	300kg
Minimum weighing	100g	200g	400g
Resolution (d)	5g	10g	20g
Accuracy	±10g	±20g	±30g
Operation temperature	-10~40°C		
Material	platform: stainless steel, base: die-cast aluminum		
Dimension of platform	420×520mm		
Power	rechargeable lead acid battery (6V/4Ah)		
Output	RS232		
Weight	18.3kg		

DATA  
OUTPUT



8501-AL150



printer (optional)

- LCD large screen display with LED backlight
- Weighing, overweight alarm, counting, keyboard lock, accumulating, auto zero and animal scale
- Units: kg, g, lb, oz

**OPTIONAL ACCESSORY**

Printer	8001-PRINTER
Data output cable (keyboard format)	7302-8001

## WEIGHING SCALES (ECONOMIC TYPE)

### SPECIFICATION

Code	8003-3	8003-6	8003-10
Maximum weighing	3kg	6kg	10kg
Minimum weighing	0.4g	2.0g	20g
Resolution (d)	0.1g	0.5g	1g
Accuracy	±0.5g	±2.5g	±5g
Weighing pan size	157×157mm		
Working temperature	5~35°C		
Power supply	2×AAA batteries, power adapter		
Dimension (L×W)	160×225mm		



8003-3

- Unit: g, oz, ct, tl

## ELECTRONIC CRANE SCALES

**IP65**  
WATERPROOF



8201-150KG



Remote controller  
(included)

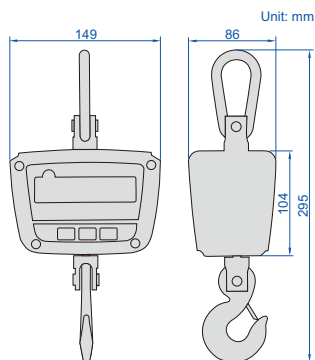

- Dust/waterproof level: IP65
- LED display, remote control
- Low voltage indicator
- Unit: kg, lb
- Automatic power off
- Overload alarm
- 360° safe rotary hook and shackle
- Aluminum alloy die casting case with high strength

### SPECIFICATION

Code	8201-50KG	8201-150KG	8201-300KG
Maximum weighing	50kg	150kg	300kg
Minimum weighing	0.4kg	1.0kg	2.0kg
Resolution (d)	0.02kg/0.01kg	0.05kg/0.02kg	0.10kg/0.05kg
Verification interval (e)	0.02kg	0.05kg	0.10kg
Accuracy	±0.02kg	±0.05kg	±0.10kg
Operation temperature	-10~40°C		
Operation humidity	30%~90% RH		
Overload alarm	100%F.S.+9e		
Maximum safe load	125%F.S.		
Limited overload	400%F.S.		
Power supply	rechargeable battery 6V/3Ah (for 40 hours working)		
Stable reading time	≤8s		

### STANDARD DELIVERY

Main unit	1 pc
Remote controller	1 pc
Battery charger	1 pc

## ELECTRONIC CRANE SCALES (BASIC TYPE)



8202-150KG



Remote controller  
(included)

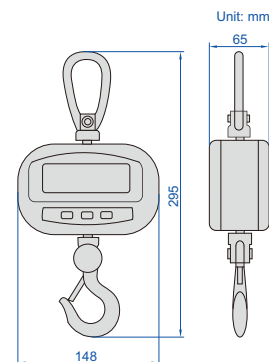

- LED display, remote control
- Low voltage indicator
- Unit: kg, lb
- Automatic power off
- Overload alarm
- 360° safe rotary hook and shackle
- Plastic case

### SPECIFICATION

Code	8202-50KG	8202-150KG	8202-300KG
Maximum weighing	50kg	150kg	300kg
Minimum weighing	0.4kg	1.0kg	2.0kg
Resolution (d)	0.02kg/0.01kg	0.05kg/0.02kg	0.10kg/0.05kg
Verification interval (e)	0.02kg	0.05kg	0.10kg
Accuracy	±0.02kg	±0.05kg	±0.10kg
Operation temperature	-10~40°C		
Operation humidity	30%~90% RH		
Overload alarm	100%F.S.+9e		
Maximum safe load	125%F.S.		
Limited overload	400%F.S.		
Power supply	4×1.5V AA batteries (for 40 hours working)		
Stable reading time	≤8s		

### STANDARD DELIVERY

Main unit	1 pc
Remote controller	1 pc



8910-200GM1

Code	Specification	Class and material
8910-100GM1	1mg~100g	M1 (304 stainless steel)
8910-200GM1	1mg~200g	M1 (304 stainless steel)
8910-1KGM1	1mg~1kg	M1 (304 stainless steel)
8910-2KGM1	1mg~2kg	M1 (304 stainless steel)
8910-5KGM1	1mg~5kg	M1 (304 stainless steel)

■ Supplied with manufacturer inspection certificate

SPECIFICATION AND SHAPE

Weight	Specification				
	1mg~100g	1mg~200g	1mg~1kg	1mg~2kg	1mg~5kg
1mg	◆	◆	◆	◆	◆
2mg	◆◆*	◆◆*	◆◆*	◆◆*	◆◆*
5mg	◆	◆	◆	◆	◆
10mg	◆	◆	◆	◆	◆
20mg	◆◆*	◆◆*	◆◆*	◆◆*	◆◆*
50mg	◆	◆	◆	◆	◆
100mg	◆	◆	◆	◆	◆
200mg	◆◆*	◆◆*	◆◆*	◆◆*	◆◆*
500mg	◆	◆	◆	◆	◆
1g	■	■	■	■	■
2g	■◆*	■◆*	■◆*	■◆*	■◆*
5g	■	■	■	■	■
10g	■	■	■	■	■
20g	■◆*	■◆*	■◆*	■◆*	■◆*
50g	■	■	■	■	■
100g	■	■	■	■	■
200g		■◆*	■◆*	■◆*	■◆*
500g			■	■	■
1kg			■	■	■
2kg				■◆*	■◆*
5kg					■
Quantity	21 pcs	23 pcs	25 pcs	27 pcs	28 pcs
Total range	1mg~211.11g	1mg~611.11g	1mg~2111.11g	1mg~6111.11g	1mg~11111.11g

◆ sheet      ■ cylinder  
◆\* sheet, with mark      ■\* cylinder, with mark



## SALT SPRAY TESTER CODE SFT-S210R



- Using plastic precision nozzle and conical spray device, the salt spray drops evenly and rapidly, the nozzle has a long working life and does not crystallize
- The spraying time can be controlled internally without external time relay
- The flow rate of salt water and the pressure of compressed air are regulated by flow meter and pressure regulating valve to ensure uniform salt spray settlement
- Manual water adding system can automatically replenish when the water level is insufficient to ensure uninterrupted test

### SPECIFICATION

Test condition	suitable for neutral and acid salt spray test
Chamber dimension (WxHxD)	900×500×600mm
Chamber volume	270L
Saline tank volume	25L
Chamber temperature	35±1°C
Saturated barrel temperature	47±1°C
Saline temperature	35±1°C
Heating mode	heat radiation
Spray mode	continuous, intermittent
Test fluid	neutral: purified water+sodium chloride (PH6.5~7.2)
Compressed air pressure	2~3kgf/cm <sup>2</sup>
Power supply	AC 220V, 1Ø, 50HZ, 2kW
Dimension (WxHxD)	1560×1250×910mm
Weight	118kg



### STANDARD DELIVERY

Main unit	1 pc
Stick	1 group
Sodium chloride	2 bottles
10L salt water preparation measuring cup	1 pc
80ml standard cup	2 pcs
50ml metering cup	2 pcs

### OPTIONAL ACCESSORY

Nozzle	SFT-S210R-NOZZLE
Brine Filter	SFT-S210R-FILTER

## DESKTOP TEMPERATURE AND HUMIDITY CHAMBER CODE THT-Z158

- Table design, quiet and small
- Equipped with operation system with 7-inch touch screen controller
- Intelligent refrigeration and dehumidification system, it can save 30~45% of electricity compared with traditional machines
- Output excel data report through USB port



### SPECIFICATION

Chamber dimension (WxHxD)	300×350×300mm	
Chamber volume	32L	
Temperature range	-40~120°C	
Humidity range	20~98%RH	
Temperature/humidity uniformity	≤2°C, ±3%RH	
Temperature/humidity fluctuation	±0.5°C, ±2.5%RH	
Temperature/humidity stability	±0.3°C, 2.5%RH	
Warm up time	1~3°C/min	
Cooling time	0.7~1°C/min	
Operation environment	environment temperature	5~35°C
	relative humidity	≤85%RH
Material	case material	cold rolled steel plate+varnish
	chamber material	SUS#304 stainless steel
	thermal insulation material	polyurethane foam
Cooling system	compressor	
Protector	compressor overload protection switch, refrigerant high pressure protection switch, ceramic fuse, water plate of water shortage protection switch, electromagnetic switch, air burn protection switch, alarm	
Power supply	AC220, 50/60HZ, 2kW	
Dimension (WxHxD)	550×850×1050mm	
Weight	185kg	



### STANDARD DELIVERY

Main unit	1 pc
Test hole	1 pc
Shelf	2 pcs

# INCH PRODUCTS

## DIAL CALIPERS

SHOCK PROOF

INSPECTION CERTIFICATE

- Dial indicator graduation 0.001"
- Shockproof dial indicator
- Made of stainless steel



1311-6

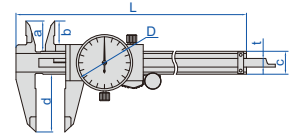

Code	Range	Accuracy	L	a	b	c	d	D	t
1311-6*	0-6"	±0.0015"	9.252"	0.827"	0.650"	0.630"	1.575"	1.535" DIA	0.256"
1311-8*	0-8"	±0.0020"	11.339"	0.945"	0.748"	0.630"	1.890"	1.535" DIA	0.256"
1311-12*	0-12"	±0.0020"	16.142"	1.102"	0.866"	0.787"	2.441"	1.752" DIA	0.295"

\*Supplied with manufacturer inspection certificate

## OUTSIDE MICROMETERS

INSPECTION CERTIFICATE



3203-2A

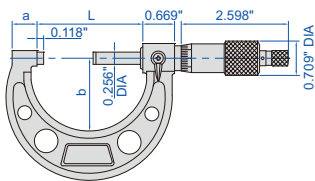

3203-44A

- Graduation 0.0001"
- Carbide measuring faces
- Ratchet stop type
- Supplied with setting standards (except 0-1")

### Individual

Code	Range	Accuracy	L	a	b
3203-1A*	0-1"	0.00015"	1.260"	0.354"	1.102"
3203-2A*	1-2"	0.00015"	2.244"	0.551"	1.496"
3203-3A*	2-3"	0.00020"	3.228"	0.591"	1.929"
3203-4A*	3-4"	0.00020"	4.213"	0.591"	2.362"
3203-5A*	4-5"	0.00025"	5.236"	0.650"	2.874"
3203-6A*	5-6"	0.00025"	6.220"	0.650"	3.346"

### Set

Code	Range	Micrometers included	Packaging
3203-33A*	0-3"	3203-1A, 3203-2A, 3203-3A	blow mould case
3203-44A*	0-4"	3203-1A, 3203-2A, 3203-3A, 3203-4A	blow mould case
3203-66A*	0-6"	3203-1A, 3203-2A, 3203-3A, 3203-4A, 3203-5A, 3203-6A	blow mould case

\*Supplied with manufacturer inspection certificate

## DEPTH MICROMETER

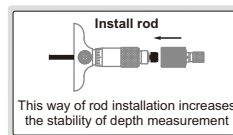

3241-6

- Graduation 0.001"
- Micrometer head accuracy: ±0.00012"
- Rod accuracy: ±[0.001+0.0005(L/3)]", L is the measuring range in inch
- Rods with flat end
- Ratchet stop

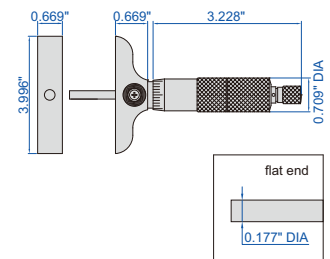

Code	Range	Rods
3241-6	0-6"	6 pcs

## DIAL INDICATOR

INSPECTION CERTIFICATE



2307-1

- Meet ASME B89.1.10M-2001
- Graduation: 0.001"
- With lug back
- Supplied with limit pointers and bezel clamp
- Optional accessory: backs, contact points

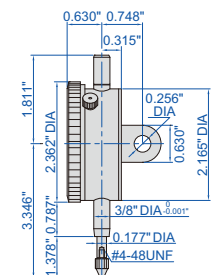

Code	Range	Accuracy		Range/rev	Dial reading
		First 2.5 rev	Overall		
2307-1*	1"	±0.001"	±0.002"	0.1"	0-100

\*Supplied with manufacturer inspection certificate

# INCH PRODUCTS

## DIAL TEST INDICATOR



**JEWELLED BEARING**

- Jeweled bearing
- Carbide contact point
- Two measuring directions
- Anti magnetic body
- Supplied with two clamps: 5/32" DIA and 3/8" DIA
- Optional accessory: styli



2380-31

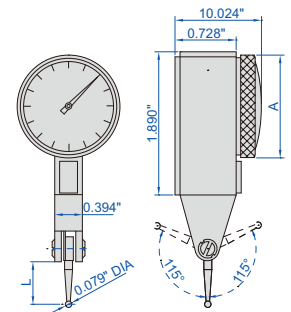
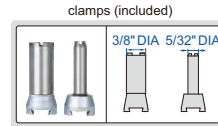

Code	Range	Graduation	Accuracy	Dial reading	A (DIA)	L
2380-31*	0.03"	0.001"	±0.001"	0-15-0	1.181"	0.50"

\*Supplied with manufacturer inspection certificate

## FEELER GAGE

- 0.010" is made of brass, others are made of hardened alloy steel
- Each blade is marked with inch/metric size



4608-31

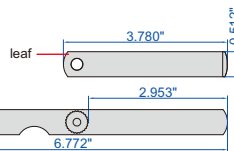

Thickness of leaves included	Accuracy
0.010" (brass)	±0.00039"
0.0015", 0.002"	±0.0002"
0.0025", 0.003", 0.004", 0.005", 0.006", 0.007"	±0.00028"
0.008", 0.009"	±0.00035"
0.010", 0.011"	±0.00039"
0.012", 0.013"	±0.00047"
0.014", 0.015"	±0.00051"
0.016", 0.017"	±0.00055"
0.018", 0.019"	±0.00059"
0.020", 0.021"	±0.00067"
0.022", 0.023"	±0.00071"
0.024", 0.025", 0.026"	±0.00075"
0.028"	±0.00091"
0.030"	±0.00094"
0.032", 0.035"	±0.00102"

Code	Range	Quantity of Leaves
4608-31	0.0015"~0.035"	32

## BORE GAGES (WITH DIAL INDICATOR)

- Optional accessory: setting ring (code 6313), long handle (code 7351) bore gage setter (code 2395-400)

**ATTENTION: NOT SUITABLE FOR 0.00005" OR 0.0001" DIAL INDICATORS**



2323-6

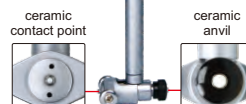
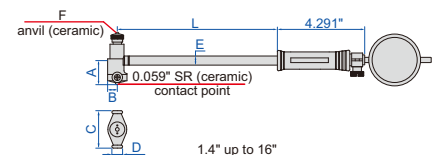
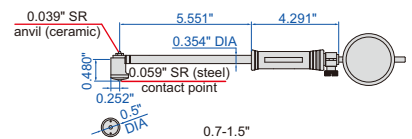

Code	Range	Indicator	Accuracy	Repeatability
2323-15	0.7-1.5"	dial indicator, range 0.25", graduation 0.0005"	±0.00075"	0.00015"
2323-24	1.4-2.4"		±0.0009"	0.00015"
2323-6	2-6"		±0.0009"	0.00015"
2323-10	6-10"		±0.0009"	0.00015"
2323-16	10-16"		±0.0009"	0.00015"

Range	A	B	C	D	E	F	L
1.4-2.4"	0.866"	0.354"	10.063"	0.512" DIA	0.504" DIA	0.079" R	5.551"
2-6"	10.024"	0.354"	1.378"	0.512" DIA	0.504" DIA	0.079" R	5.551"
6-10"	2.224"	0.512"	2.933"	0.591" DIA	0.504" DIA	0.079" R	9.488"
10-16"	3.406"	0.591"	3.996"	0.591" DIA	0.571" DIA	0.098" R	9.488"

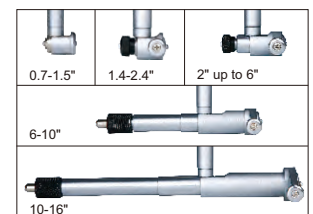

## CODE NO. INDEX

CODE	PAGE	CODE	PAGE	CODE	PAGE	CODE	PAGE
<b>00</b>		1141	28	1236	11	2139	70
0010	220	1142	28	1239	10	2140	74
0011	220	1143	29	1240	30	2141	32
0020	213	1144	29	1244	31	2144	117
0022	214	1145	31	1246	94	2146	94
<b>01</b>		1146	94	1250	37	2147	94
0110	219	1147	28	1251	37	2149	73
0120	218	1148	29	1253	37	2151	88
0130	221	1149	27	1262	18	2152	60
0131	221	1150	35	1267	66	2153	59
0140	218	1151	36	1273	26	2164	93
<b>02</b>		1154	36	1275	137	2166	93
0213	230	1155	33	1281	26	2168	93
0222	230	1156	35	1291	20	2170	155
<b>03</b>		1157	34	<b>13</b>		2171	111
0310	233	1158	34	1311	10	2174	110
0311	232	1160	127	1312	10	2175	154
0313	233	1161	24	1316	10	2176	111
0320	233	1162	27	1340	30	2179	154
0321	231	1165	25	1341	30	2182	95
<b>04</b>		1166	138	1351	36	2183	64
0411	215	1167	27	1376	19	2184	93
0412	215	1168	27	<b>15</b>		2186	92
0431	216	1169	21	1501	66	2187	101
0432	216	1170	8	1520	17	2188	65
<b>05</b>		1171	8	1521	22	2197	64
0501	222	1172	25	1524	23	2198	156
<b>06</b>		1176	18	1525	22	2199	155
0611	221	1177	23	1526	13~14	<b>22</b>	
0612	222	1178	19	1527	24	2222	88
<b>11</b>		1179	24	1528	25	2223	89
1102	5	1180	67	1530	15	2275	115
1103	5	1181	26	1532	21	2276	136
1106	10	1183	21	1533	25	2278	136
1108	6	1185	20	1536	26	2280	116
1109	6	1186	23	1537	67	2281	137
1110	7	1187	20	1538	27	2282	137
1111	8	1188	21	1539	26	<b>23</b>	
1113	4	1189	66	1540	30	2301	75
1114	5	1191	20	1543	28	2302	75
1115	4	1192	22	<b>21</b>		2308	74
1118	4	1193	7	2103	69	2309	76
1119	6	1196	6	2104	69	2310	75
1120	17	1199	18	2108	71	2311	74
1121	17	<b>12</b>		2112	69	2313	74
1122	23	1201	8	2114	72	2314	75
1123	21	1202	9	2115	71	2316	76
1124	15	1203	8	2117	72	2322	60
1125	16	1204	8	2118	72	2324	75
1128	20	1205	9	2121	88	2328	76
1129	19	1207	12	2122	60	2333	90
1130	7	1208	12	2124	58	2341	32
1135	11	1214	11	2126	59	2342	32
1136	11	1215	11	2131	90	2343	31
1138	22	1217	9	2132	89	2344	205
1139	8	1223	9	2133	73	2361	91
1140	31	1224	9	2138	70	2363	91

**CODE NO. INDEX**

CODE	PAGE
2364	90
2372	112
2373	112
2374	112
2380	67
2381	67
2383	67
2385	148
2386	68
2394	153
2396	78
2397	153
2398	68
2399	68
<b>24</b>	
2480	68
<b>25</b>	
2511	65
<b>27</b>	
2771	113
<b>28</b>	
2824	61
2825	59
2828	61
2841	95
2852	60
2853	59
2862	91
2870	91
2871	90
2872	90
2876	91
2878	92
2879	91
<b>29</b>	
2931	38
2932	39-40
<b>31</b>	
3101	42
3108	42
3109	43
3127	57
3128	58
<b>32</b>	
3202	43
3203	44
3206	44
3210	44
3220	55
3221	55
3222	55
3227	56
3228	57
3230	48
3232	48
3233	49
3234	51

CODE	PAGE
3236	43
3238	53
3239	50
3240	33
3241	33
3260	50
3261	49
3262	50
3266	49
3280	52
3281	46
3282	53
3283	52
3285	53
3287	45
3290	51
3291	47
3293	53
<b>33</b>	
3331	45
3332	45
3334	93
3350	42
3358	41
3359	41
<b>35</b>	
3506	45
3520	55
3521	56
3530	48
3532	48
3533	49
3534	51
3539	50
3540	32
3560	50
3561	49
3562	51
3565	43
3566	49
3580	52
3581	47
3583	52
3590	51
3591	47
3594	53
<b>40</b>	
4006	145
<b>41</b>	
4100	95
4101	96
4108	97
4110	99
4120	107
4121	110
4124	104
4129	108-109

CODE	PAGE
4130	105
4131	109
4139	106-107
4141	113
4142	144
4143	145
4147	116
4155	146
4158	146
4160	97
4166	98
4176	96
4180	116
4190	103
4192	99
4193	99
<b>42</b>	
4206	62
4208	62
4209	62
<b>46</b>	
4601	122
4602	122
4605	122
4621	123
4623	122
4624	122
4630	127
4666	104
<b>47</b>	
4700	116
4707	115
4721	119
4725	118
4728	121
4737	119
4738	120
4739	120
4741	121
4747	116
4770	113
4771	121
4780	111
4781	111
4782	119
4786	118
4789	117
4790	114
4791	114
4792	115
4793	115
4796	114
4797	112
4799	111
<b>48</b>	
4801	125
4802	125

CODE	PAGE
4803	126
4804	125
4806	125
4807	124
4808	126
4809	126
4810	124
4812	124
4820	123
4824	123
4829	136
4830	128
4831	128
4832	128
4833	127
4834	129
4835	130
4836	128
4837	127
4838	130
4839	132
4840	131
4841	131
4842	126
4843	125
4844	66
4845	205
4846	131
4847	129
4848	129
4849	130
4850	130
4851	131
4852	128
4853	127
4854	126
4855	128
4860	124
<b>49</b>	
4902	156
4903	156
4910	157
4911	158
4912	157
4913	157
4914	157
4917	158
4918	158
<b>50</b>	
5013	139
5022	138
5023	138
5024	139
5041	139
5042	139
5052	139
5063	139

## CODE NO. INDEX

CODE	PAGE	CODE	PAGE	CODE	PAGE	CODE	PAGE
5064	132	6227	85	6864	86	7260	133
5071	132	6228	83	6865	88	7261	133
5072	132	6229	82	6866	86	7262	132
5091	139	6230	85	6867	86	<b>73</b>	
<b>51</b>		6272	83	6869	87	7302	1
5101	186	6282	76~77	6876	85	7304	3
5102	188	6284	68	6878	143	7315	2~3
5103	186	6291	81	6879	145	7330	78
5106	190	6293	81	6884	97	7331	78
5107	188	6294	81	6887	141	7332	77
5108	187	6295	81	6888	141	7341	101
<b>52</b>		6296	81	6889	142	7342	99
5201	219	6297	81	6890	143	7344	100
<b>53</b>		6298	68	6891	143	7345	99
5301	175	<b>63</b>		6896	141	7351	61
5302	174	6300	54	6897	142	7353	62
5305	191	6301	54	<b>69</b>		7381	47
5307	181	6310	54	6900	140	7382	46
5310	178	6312	102	6902	140	7391	48
5311	183	6381	54	6990	138	7394	46
5313	175	<b>65</b>		<b>71</b>		<b>75</b>	
5316	180	6511	144	7101	159	7511	195
5317	179~180	6513	147	7106	79	7512	197
5318	176	6520	147	7107-1	80	7513	196
5319	182	6521	147	7107-11	79	7514	195
<b>57</b>		6526	148	7107-12	79	7515	195
5700	209	6527	146	7107-2	80	7516	194
5701	208	6531	145	7107-3	80	7517	193
5702	206	6533	144	7110	135	7520	194
<b>58</b>		6534	144	7111	116	7521	194
5801	217	6535	146	7114	63	7522	197
5804	223	6537	144	7119	135	7523	197
5805	223	6538	147	7120	137	7524	196
<b>59</b>		6539	143	7123	136	7525	194
5900	223	6540	113	7130	80	7526	195
<b>61</b>		6547	146	7135	63	7527	196
6140	12	6553	153	7136	64	7528	196
6141	31	6556	153	7137	63	7529	196
6143	21	6557	153	7139	134	7530	197
6144	12	6562	149	7140	133	<b>76</b>	
6145	13	6566	149	7142	133	7600	217
6146	13	6567	149	7143	134	<b>80</b>	
<b>62</b>		6568	150	7144	135	8001	271
6200	83	6572	149	7145	135	8002	271
6201	83	6573	149	7160	198	8003	273
6202	83	6582	148	7161	198	<b>81</b>	
6207	84	6584	148	7162	198	8101	271
6210	82	<b>68</b>		7163	198	<b>82</b>	
6211	84	6801	142	7164	198	8201	273
6214	84	6805	141	<b>72</b>		8202	273
6216	84	6832	129	7202	137	<b>83</b>	
6217	84	6841	85	7203	138	8301	270
6219	82	6842	87	7205	137	8303	269
6221	83	6845	87	7230	138	8304	269
6224	83	6852	117	7231	138	8305	270
6225	85	6862	86	7232	138	8310	268
6226	84	6863	86	7247	133	<b>85</b>	



**CODE NO. INDEX**

CODE	PAGE
8501	272
<b>86</b>	
8601	272
8602	272
<b>89</b>	
8910	274
<b>91</b>	
9132	229
<b>92</b>	
9216	225
9219	228
9223	212
9224	213
9225	212
9241	225
9242	226
9246	226
9247	227
<b>93</b>	
9315	227
9341	218
9353	219
9362	231
<b>94</b>	
9410	150
9411	152
9412	152
9413	151
<b>95</b>	
9501	203
9511	205
9561	214
9563	134
<b>96</b>	
9651	224
<b>97</b>	
9720	213
9721	229
9722	229
9723	228
<b>99</b>	
9911	224
<b>DSW</b>	
DSW-A010	217
<b>EMU</b>	
EMU-S340	209
<b>GRL</b>	
GRL-L340	159
<b>HDT</b>	
HDT-L410	253
HDT-L411	254
HDT-LP200	251
HDT-LP200B	251
HDT-MB610	249
HDT-MB710	249
HDT-MBE320	248
HDT-MVE1300	244

CODE	PAGE
HDT-MVH1100	245
HDT-RA151	243
HDT-RT151	241
HDT-RW160	243
HDT-VE□□□	246
HDT-VH□□□	247
HDT-WP201	252
<b>ISD</b>	
ISD-V150A	170
ISD-V220CNCA	171
ISD-V250A	170
ISD-V270CNCA	171
ISD-V300A	170
ISD-V370CNCA	171
ISD-VMM215	173
ISD-W3150	169
<b>ISE</b>	
ISE-2DT	154
<b>ISF</b>	
ISF-1DF□□□	260
ISF-DF□□□	260
ISF-F□□□	261
ISF-H20D	262
ISF-MT1K	261
ISF-MT500	261
ISF-P30D	262
ISF-RH62	262
ISF-RV61	262
ISF-S□□□	259
ISF-TG□□□	263
ISF-U055	259
ISF-U101	259
ISF-U202	259
<b>ISGF</b>	
ISGF-0901	138
<b>ISHB</b>	
ISHB-B300	255
<b>ISH</b>	
ISH-BRV	250
ISH-DSA	255
ISH-DSD	255
ISH-DS-STANDA	256
ISH-MRD200	242
ISH-R150	242
ISH-SAM	256
ISH-SDM	256
ISH-STAC	256
<b>ISHR</b>	
ISHR-P151	254
<b>ISHW</b>	
ISHW-H□□□	255
<b>ISL</b>	
ISL-A1-□□□	160
ISL-A5-□□□	160
ISL-B5-□□□	160
ISL-DR2	161
ISL-DR3	161

CODE	PAGE
ISL-LCD7	161
<b>ISM</b>	
ISM-CM63	192
ISM-CT820	181
ISM-DL301	177
ISM-PM100	193
ISM-PM200SA	184
ISM-WF200	185
ISM-ZS100	189
ISM-ZS100T	189
ISM-ZS200	189
ISM-ZS30	191
ISM-ZS50	190
ISM-ZS50T	190
ISM-ZS70-S	193
<b>ISO</b>	
ISO-1000FN	204
ISO-1200FN	204
ISO-8000FN	202
<b>ISQ</b>	
ISQ-DG6	206
ISQ-DG8	207
ISQ-DRM31	217
ISQ-RM30	217
<b>ISR</b>	
ISR-C002	236
ISR-C003	240
ISR-C300	237-238
ISR-CS130-W	240
ISR-T120	238-239
<b>IST</b>	
IST-04TT□□□	263
IST-11WM□□□	265
IST-19WM□□□	266
IST-9WM□□□	266
IST-DW□□□	267
IST-MG□□□	263
IST-PW□□□	267
IST-SD200	264
IST-SD50	264
IST-W□□□	264
<b>ISU</b>	
ISU-100D	211
ISU-250C	211
ISU-720D	210
<b>ISV</b>	
ISV-E30	201
ISV-E40	201
ISV-K□□□	199
ISV-P6	200
ISV-S106	200
<b>ISY</b>	
ISY-100	165-166
ISY-400	164
ISY-500	164
ISY-600	166
ISY-700	172

CODE	PAGE
<b>ITM</b>	
ITM-S150J	258
ITM-S300J	258
<b>LDM</b>	
LDM-030	162
LDM-065	162
<b>QMS</b>	
QMS-A110	167
QMS-A220	168
<b>RCT</b>	
RCT-RA260	234
<b>SFT</b>	
SFT-S210R	275
<b>SPM</b>	
SPM-1000	235
<b>THT</b>	
THT-Z158	275
<b>TLP</b>	
TLP-300H	162
<b>UFD</b>	
UFD-T680	163
<b>UTM</b>	
UTM-E□□□	257
<b>INCH PRODUCTS</b>	
<b>13</b>	
1311	276
<b>23</b>	
2307	276
2323	277
2380	277
<b>32</b>	
3203	276
3241	276
<b>46</b>	
4608	277



**INSIZE EUROPE S.L.**  
Add: Aresti No 8, 48160, Derio, Spain  
Tel: +34-94-4544308  
E-mail: europe@insize.com  
Website: www.insize-eu.com



[www.insize-eu.com](http://www.insize-eu.com)

Obtain information about our complete line of product from our website or general catalogue



Distributed by:

We reserve the right to change or modify the design and specification of products in this catalogue without prior notice.